

MI0805J102R-10

PHYSICAL DIMENSIONS:

A	2.00 [.079]	+ 0.20 [.008]
B	1.25 [.049]	+ 0.20 [.008]
C	0.90 [.035]	+ 0.20 [.008]
D	0.51 [.020]	+ 0.25 [.010]

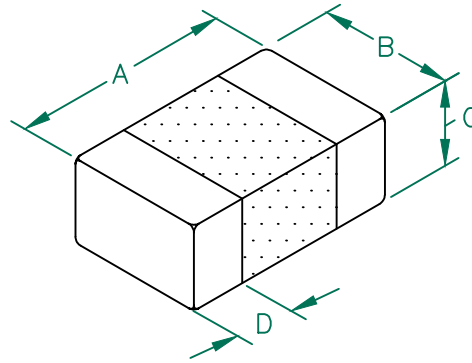

ELECTRICAL CHARACTERISTICS:

	Z @ 100MHz (Ω)	DCR (Ω)	Rated Current
Nominal	1000		
Minimum	750		
Maximum	1250	0.15	1000 mA

NOTES: UNLESS OTHERWISE SPECIFIED

1. TAPED AND REELED per CURRENT EIA SPECIFICATIONS 7" REELS, 4000 PCS/REEL, PAPER TAPE.
2. COMPONENTS SHOULD BE ADEQUATELY PREHEATED BEFORE SOLDERING.
3. TERMINATION FINISH IS 100% TIN.
4. OPERATING TEMP. RANGE: -40°C~+125°C. (INCLUDING SELF-HEATING)
5. COSMETIC SPECIFICATION REFER TO WI-QA-124.

Z vs FREQUENCY
IMPEDANCE UNDER DC BIAS

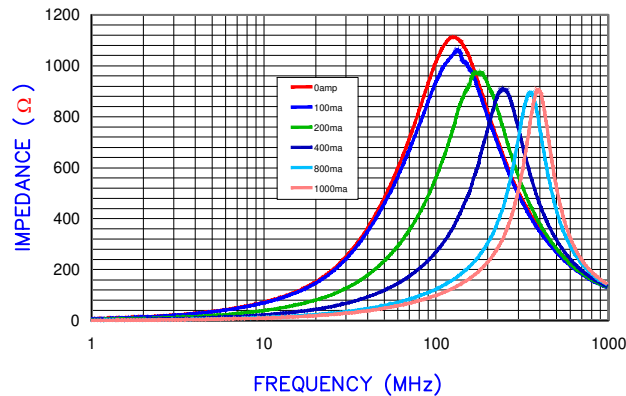

LAND PATTERNS FOR REFLOW SOLDERING

RECOMMENDED SOLDERING CONDITIONS

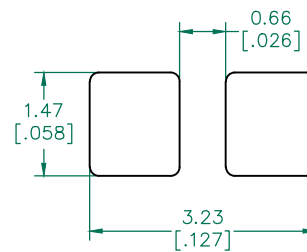

(For wave soldering, add 0.763 [.030] to this dimension.)

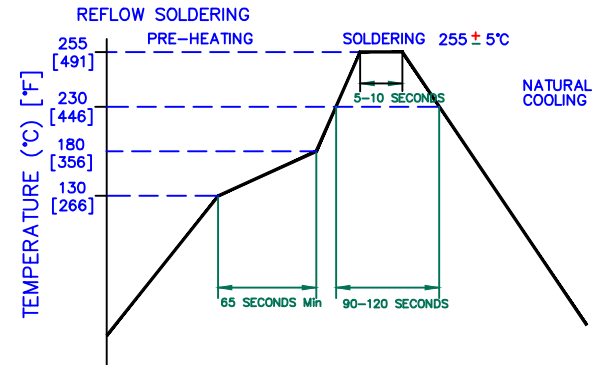

|Z|, R, AND X vs. FREQUENCY

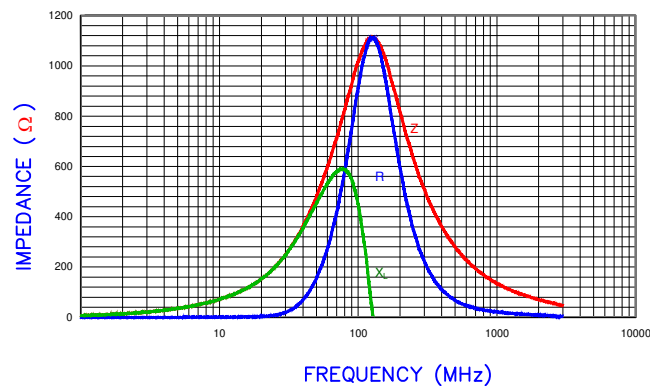

Z R X_L



DIMENSIONS ARE IN mm [INCHES].

This print is the property of Laird Tech. and is loaned in confidence subject to return upon request and with the understanding that no copies shall be made without the written consent of Laird Tech. All rights to design or invention are reserved.			Laird		
D	ADD OPERATING TEMPERATURE UPDATE LAIRD LOGO AND REFLOW CURVE	08/05/13	QU	PROJECT/PART NUMBER: MI0805J102R-10	REV D PART TYPE: CO-FIRE DRAWN BY: JRK
C	CHANGE TO PAPER TAPE	03/04/10	JUN	DATE: 12/17/04	SCALE: NTS SHEET: 1 of 1
B	UUPDATE COMPANY LOGO ADD ROHS SYM	07/25/08	JRK	CAD #	TOOL # -
A	ORIGINAL DRAFT	12/17/04	JRK		
REV	DESCRIPTION	DATE	INT	MI0805J102R-10-D	