

PRODUCT SPECIFICATION

Part Number	SIM4065	Rev	A	Date	24/10/14		
Product Description	SIM Card Connector, Push Push Type, 8 Pin, SMT with Card Detect, 1.6mm Profile.			Page	1		
Doc Number	SIM4065	Prepared	AO	Checked	ST	Approved	VJ

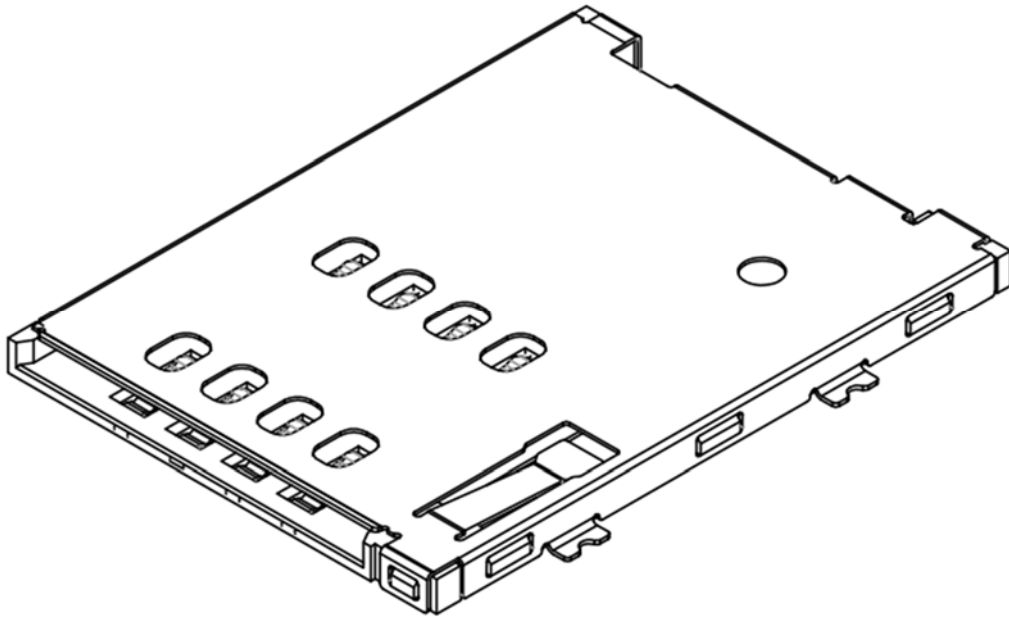

PRODUCT SPECIFICATION

Part Number	SIM4065	Rev	A	Date	24/10/14
Product Description	SIM Card Connector, Push Push Type, 8 Pin, SMT with Card Detect, 1.6mm Profile.			Page	2
Doc Number	SIM4065	Prepared	AO	Checked	ST
				Approved	VJ

1.0 SCOPE.

This specification covers performance, tests and quality requirements for the SIM Card Connector SIM 4065 (Push Push Type, 8-Pin, SMT, 1.6mm Profile).

2.0 PRODUCT NAME AND PART NUMBER.

SIM Card Connector, 8 Pin, Push Push Type: SIM4065.

3.0 PRODUCT SHAPE, DIMENSIONS AND MATERIAL.

Please refer to drawings.

4.0 RATINGS.

Current rating 1.0 Amp DC
 Voltage rating 50 Volts AC (RMS) Max.
 Operating Temperature Range -40°C to +85°C

5.0 TEST AND MEASUREMENT CONDITIONS.

Product is designed to meet electrical, mechanical and environmental performance requirements specified in Paragraph 6.0. All tests are performed under the following conditions unless otherwise specified.

Temperature 15°C ~ +35°C
 Relative Humidity 45% ~ 75% R.H.

6.0 PERFORMANCE.

Item	Test Condition	Requirement
Examination of Product	Visual, dimensional and functional inspection as per quality plan.	Product shall meet requirements of product drawing and specification.

PRODUCT SPECIFICATION

Part Number	SIM4065	Rev	A	Date	24/10/14
Product Description	SIM Card Connector, Push Push Type, 8 Pin, SMT with Card Detect, 1.6mm Profile.			Page	3
Doc Number	SIM4065	Prepared	AO	Checked	ST
				Approved	VJ

6.1 Electrical Performance.

Item	Test Condition	Requirement
Contact Resistance	Measure and record contact resistance of mated connector using test current of 10mA max and 20 mV open circuit voltage in accordance with EIA-364-23A.	Signal 100 mΩ max Switch 300 mΩ max
Insulation Resistance	Apply 500Volts DC between adjacent contacts of mated connectors for one minute in accordance with EIA-364-21C.	1000 MΩ minimum
Dielectric Strength	Mate connectors and apply 500 V AC for 1 minute between adjacent terminal or ground, in accordance with EIA-364-20B.	No creeping discharge or flash over.

6.2 Mechanical Performance.

Item	Test Condition	Requirement
Durability	The connector should be mated and unmated for 5000 cycles at a rate of 10 cycles/ minute in accordance with EIA-RS-364-09A.	No evidence of physical damage. Contact Resistance Signal $\leq 100\text{m}\Omega$. Switch $\leq 300\text{m}\Omega$ at end of test
Vibration	Subject mated connectors to 10 to 55 to 10 Hz frequency span over 1 minute at a 1.52mm amplitude for a total of 15 minutes. Test to be conducted on 3 mutually perpendicular planes. In accordance with EIA-364-28.	No evidence of physical damage Contact Resistance $\leq 100\text{m}\Omega$ Current discontinuity $\leq 1\mu\text{s}$ at end of test
Mechanical Shock	Apply DC and 1mA to all contacts and subject the part to a 294 m/s ² half sine wave acceleration for 11 ms. Three shocks to be applied in each of the X, Y and Z planes and in both directions. A total of 18 shocks and in accordance with EIA-364-27B.	No evidence of physical damage Contact Resistance $\leq 100\text{m}\Omega$ Current discontinuity $\leq 1\mu\text{s}$ at end of test.

PRODUCT SPECIFICATION

Part Number	SIM4065	Rev	A	Date	24/10/14
Product Description	SIM Card Connector, Push Push Type, 8 Pin, SMT with Card Detect, 1.6mm Profile.			Page	4
Doc Number	SIM4065	Prepared	AO	Checked	ST
				Approved	VJ

6.3 Environmental Performance and Others.

Item	Test Condition	Requirement
Thermal Shock	Mate Connector and perform the following thermal cycle :- -40+/-3°C for 30 minutes. +25°C for 5 minutes. +85+/-2°C for 30 minutes. +25°C for 5 minutes. Repeat for 5 cycles in accordance with EIA-364-32C.	No evidence of physical damage, discharge, flashes Contact Resistance Signal $\leq 100\text{m}\Omega$. Switch $\leq 300\text{m}\Omega$ at end of test Insulation Resistance $\geq 1000\text{ M}\Omega$
Humidity Test	Mate connector and expose to temperature of $40\pm 2^\circ\text{C}$ with 95% RH for 96 hours then place in ambient temperature for 1 to 2 hrs. In accordance with EIA-RS-364-31A.	No evidence of physical damage, discharge, flashes Contact Resistance Signal $\leq 100\text{m}\Omega$. Switch $\leq 300\text{m}\Omega$ at end of test Insulation Resistance $\geq 1000\text{ M}\Omega$
Salt Water Spray	Subject mated connectors to $35\pm 2^\circ\text{C}$ and $5\pm 1\%$ salt condition for 24 hours. Test in accordance with EIA-RS-364-26B.	Contact Resistance Signal $\leq 100\text{m}\Omega$. Switch $\leq 300\text{m}\Omega$ at end of test No pin hole, corrosion on contact area
Temperature Life (High)	Subject mated connectors to $85^\circ\text{C} \pm 2^\circ\text{C}$ for 250 hours in accordance with EIA-364-17B.	No evidence of physical damage Signal $\leq 100\text{m}\Omega$. Switch $\leq 300\text{m}\Omega$ at end of test
Solderability	Dip solders tails into molten solder, held at a temperature of $245\pm 5^\circ\text{C}$ for 5 ± 0.5 second, in accordance with EA-364-52.	95% of immersed area must show no voids of pin holes.
Resistance to Reflow Soldering Heat.	Mount connector, place in reflow oven and expose to the temperature profile shown in fig 1.0	No evidence of physical damage

PRODUCT SPECIFICATION

Part Number	SIM4065	Rev	A	Date	24/10/14		
Product Description	SIM Card Connector, Push Push Type, 8 Pin, SMT with Card Detect, 1.6mm Profile.			Page	5		
Doc Number	SIM4065	Prepared	AO	Checked	ST	Approved	VJ

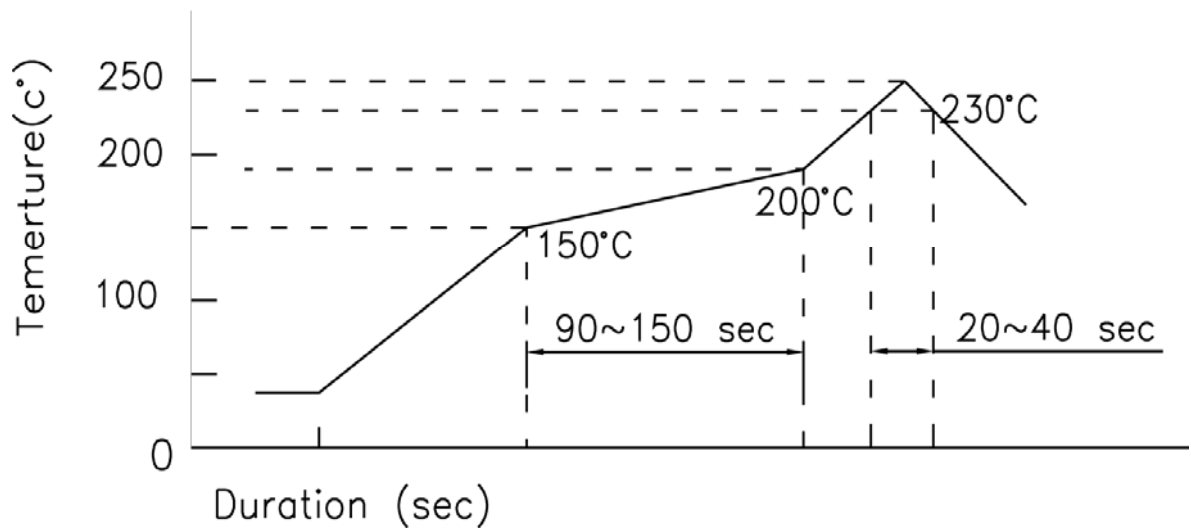

Fig. 1. Recommended Reflow Temp. Profile

PRODUCT SPECIFICATION

Part Number	SIM4065	Rev	A	Date	24/10/14		
Product Description	SIM Card Connector, Push Push Type, 8 Pin, SMT with Card Detect, 1.6mm Profile.				Page	6	
Doc Number	SIM4065	Prepared	AO	Checked	ST	Approved	VJ

7.0 PRODUCT QUALIFICATION AND TEST SEQUENCE

Test Item	Group						
	A	B	C	D	E	F	G
Examination of Product	1,4	1,6	1,10	1,5	1,5	1,3	1,3
Contact Resistance	2,5	2,5	2,7	2,4	2,4		
Insulation Resistance			3,8				
Dielectric Strength			4,9				
Durability	3						
Vibration		4					
Mechanical shock		3					
Thermal Shock			5				
Humidity			6				
Salt Water Spray				3			
Temperature Life(high)					3		
Solderability						2	
Resistance to Reflow Soldering Heat.							2
Sample QTY.	5	5	5	5	5	5	5
The Number of Group is Test Sequence (Drop Test Sample QTY 1)							

Notes:

Numbers indicate sequence in which tests are performed.
Precondition samples with 10 cycle's durability.

SAMPLE SELECTION

Samples shall be prepared in accordance with applicable manufactures' instructions and shall be randomly selected from current production. Test groups A,B,C,D,E,F &G shall consist of a minimum of five connectors. A minimum of 30 contacts shall be selected and identified.

Unless otherwise specified, these contacts shall be used for all measurements.