

rev	ecn no	dr	date
A	V05-0062	TAB	2005/01/19
B	V05-0052	VS	2005/10/14
C	V06-0558	LP	2006/06/12
D	V07-0440	LP	2007-07-05
-	-	-	-
-	-	-	-

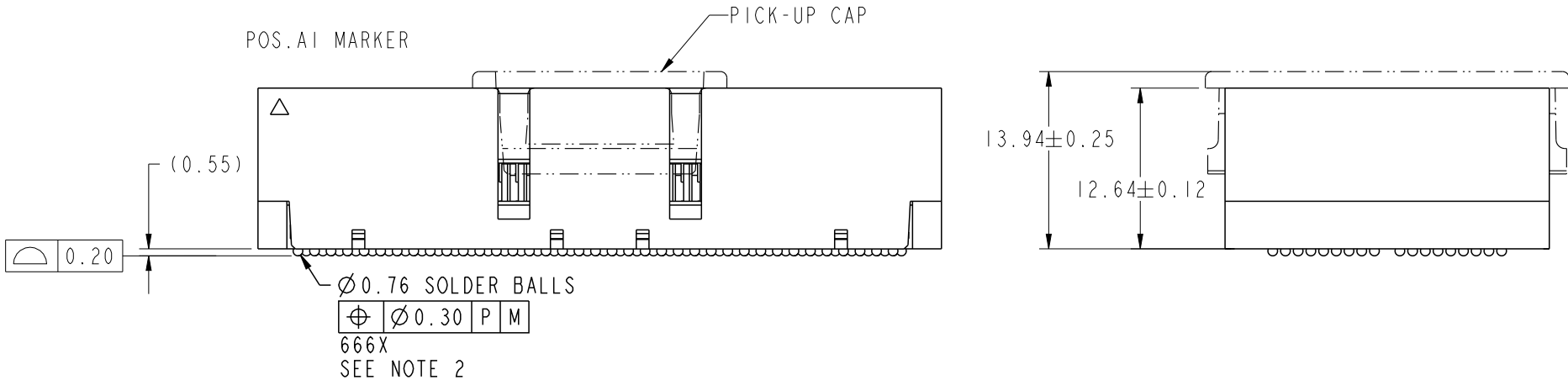
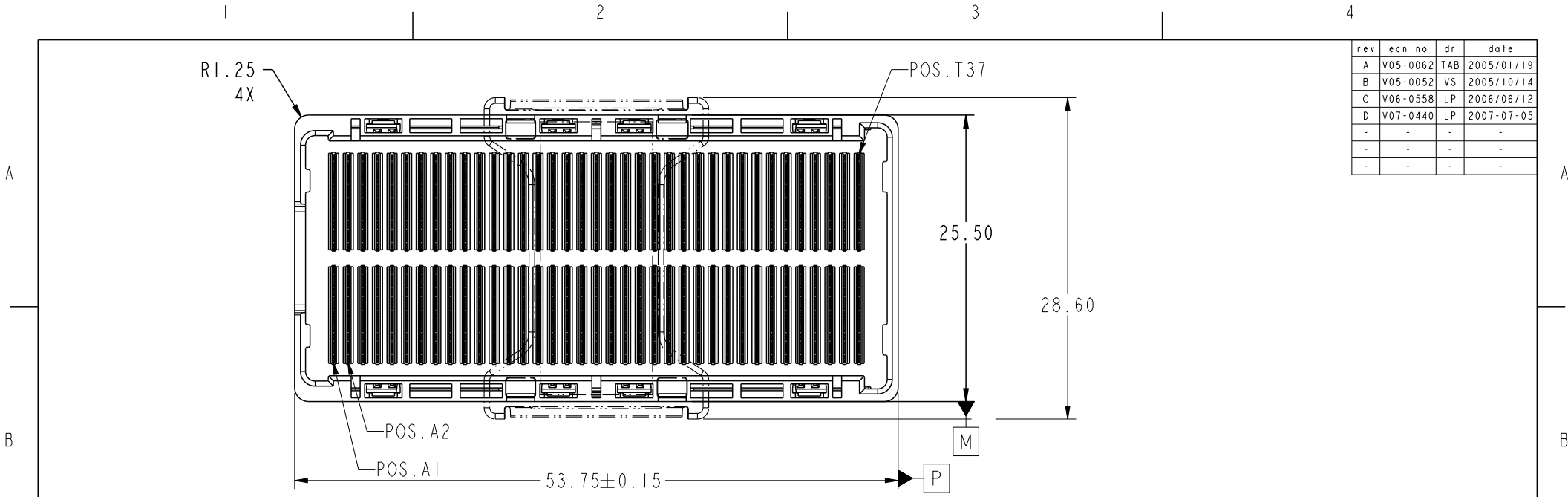

Copyright FCI.

spec ref	-	dr	Louis Ng	2010/11/01	projection 	mm 	size	A4	scale	1:1	
tolerance std	TOLERANCES UNLESS OTHERWISE SPECIFIED	eng	Nickor Zuo	2011/06/24			ecn no	ELX-DG-003943-1			
-	-	chr	Alex Cao	2011/06/24			product family	GIG-Array			
-	-	appr	Pei-Ming Zheng	2011/06/27			rel level	Released			
surface	3.2	linear	0.X	±0.30	 <b>GIG-Array</b> 13mm PLUG ASSY. 296 SIG. POS.	dwg no	10008026		rev	D	
			0.XX	±0.10			cat. no.	Product - Customer Drw		sheet 1 of 5	
			0.XXX	±0.05							
ASME Y14.5		angular	0°	±2°	www.fci.com						

ProjE File - REV C - 2009-06-09



Copyright FCI.

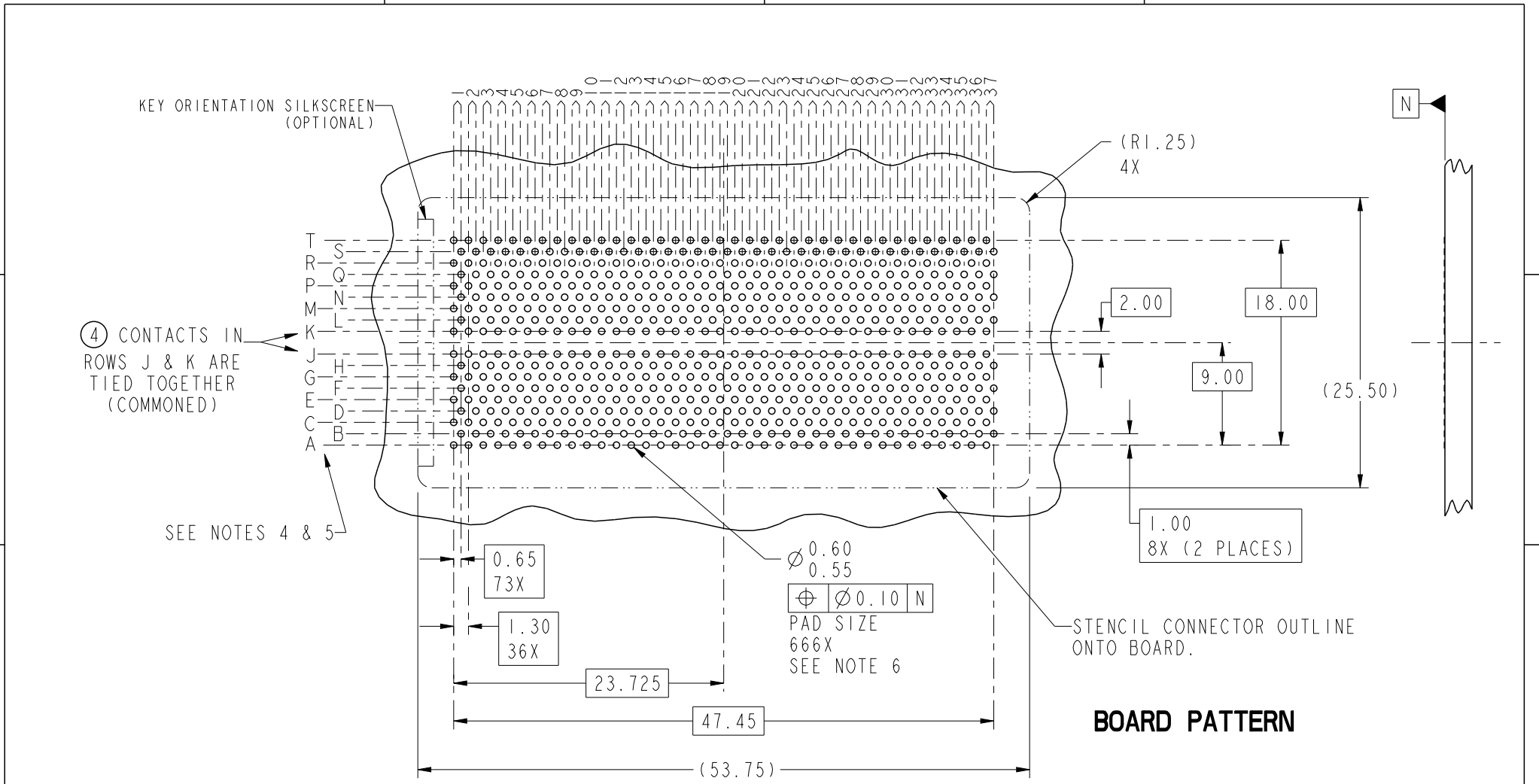

**BOARD PATTERN**

spec ref -		dr <b>Louis Ng</b> 2010/11/01		projection		size A4		scale 1:1	
tolerance std -		eng <b>Nickor Zuo</b> 2011/06/24				mm		ecn no ELX-DG-003943-1	
-		chr <b>Alex Cao</b> 2011/06/24						rel level <b>Released</b>	
-		appr <b>Pei-Ming Zheng</b> 2011/06/27		product family GIG-Array		rev		D	
surface 3.2		linear				title GIG-Array 13mm PLUG ASSY. 296 SIG. POS.		dwg no 10008026	
ASME Y14.5		angular							
		0.X ±0.30 0.XX ±0.10 0.XXX ±0.05		www.fci.com					

Proj File - REV C - 2009-06-09



Copyright FCI.

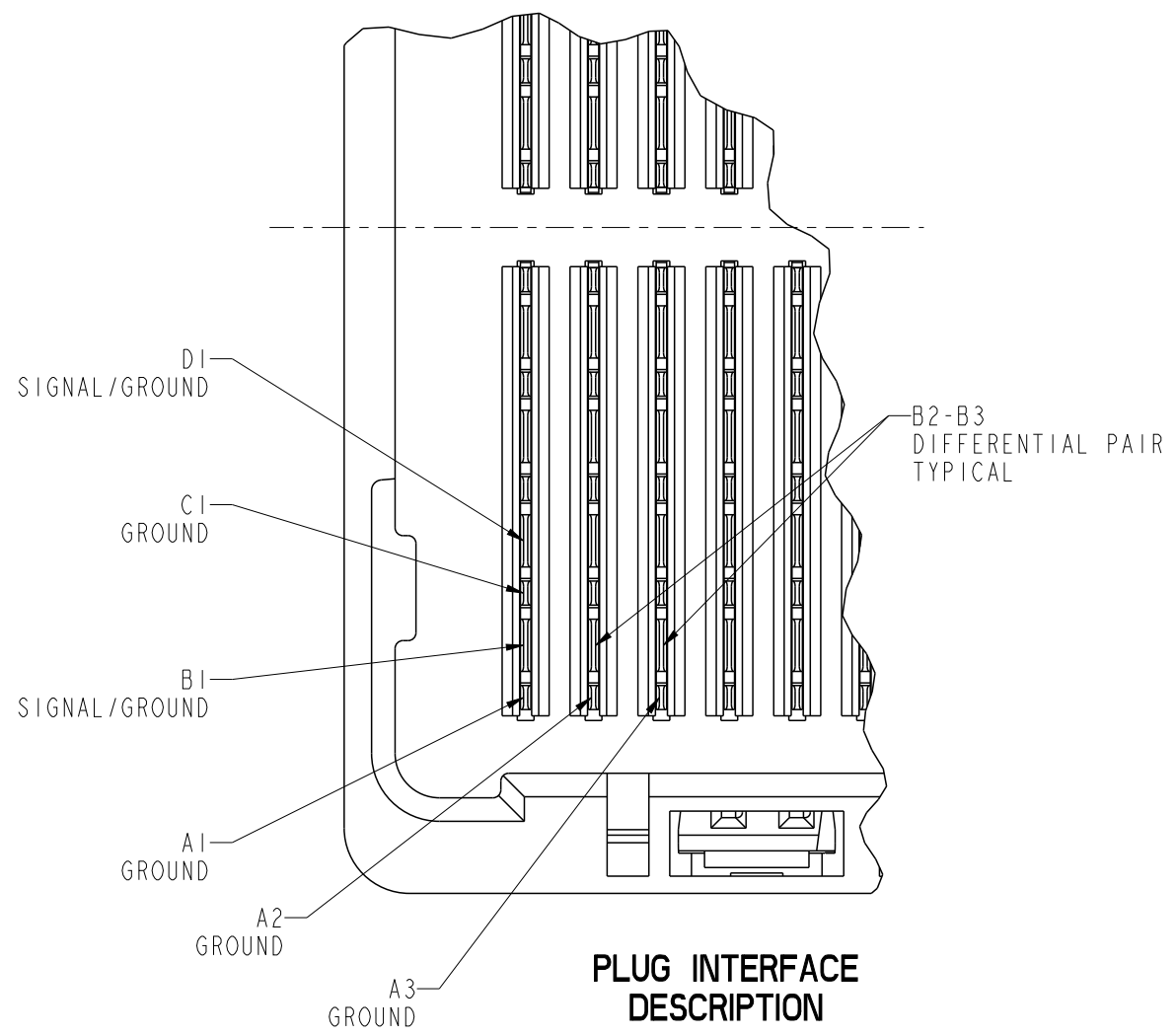

spec ref		-		dr	Louis Ng	2010/11/01	projection 	mm 	size	A4	scale	1:1		
tolerance std		TOLERANCES UNLESS OTHERWISE SPECIFIED		eng	Nickor Zuo	2011/06/24			product family	GIG-Array	ecn no			ELX-DG-003943-1
-		-		chr	Alex Cao	2011/06/24					rel level			Released
-		-		appr	Pei-Ming Zheng	2011/06/27	title		GIG-Array		rev			
surface 3.2		linear	0.X	±0.30	www.fci.com	title			13mm PLUG ASSY. 296 SIG. POS.		dwg no		10008026	
ASME Y14.5			0.XX	±0.10		cat. no.			-		Product - Customer Drw		sheet 3 of 5	
			0.XXX	±0.05										
		angular	0°	±2°										

Pro/E File - REV C - 2009-06-09

**FLAT AREA  
PICK-UP CAP**

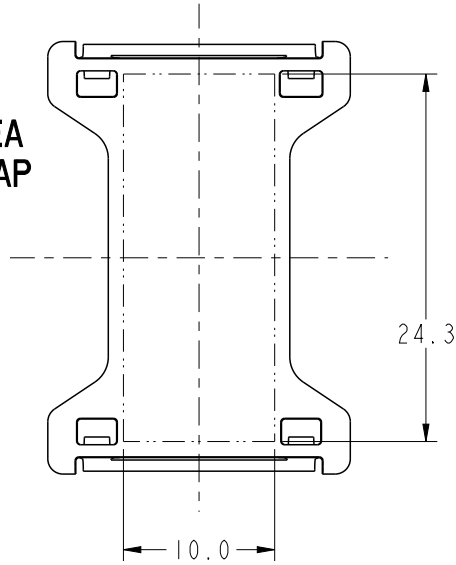

**END VIEW OF MATED CONNECTORS**

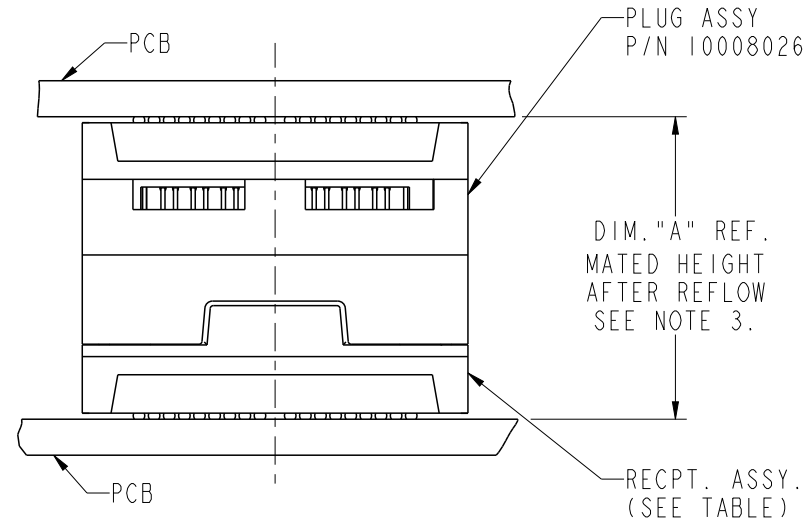

DIM. "A"	RECPT. ASSY. P/N
18	55701
23	10032376
28	55733

NOT TOOLED

spec ref -		dr <b>Louis Ng</b> 2010/11/01		projection 	mm 	size A4	scale 1:1	
tolerance std -		eng <b>Nickor Zuo</b> 2011/06/24				ecn no ELX-DG-003943-1		
-		chr <b>Alex Cao</b> 2011/06/24				rel level <b>Released</b>		
-		appr <b>Pei-Ming Zheng</b> 2011/06/27		product family GIG-Array		rev <b>D</b>		
surface 3.2 ASME Y14.5	linear	0.X	±0.30		title GIG-Array 13mm PLUG ASSY. 296 SIG. POS.	dwg no 10008026	sheet 4 of 5	
		0.XX	±0.10					
		0.XXX	±0.05					
	angular	0°	±2°	www.fci.com	cat. no. -	Product - Customer Drw		

PRODUCT NUMBER	SOLDER BALL COMPOSITION	CONTACT PLATING PERFORMANCE LEVEL
10008026-001	STANDARD (EUTECTIC)	PERFORMANCE-BASED PLATING, QUALIFIED TO MEET THE REQUIREMENTS OF FCI PRODUCT SPECIFICATION GS-12-192, INCLUDING TELCORDIA CENTRAL OFFICE  Au over Ni
10008026-001LF	LEADFREE	
10008026-201	STANDARD (EUTECTIC)	
10008026-201LF	LEADFREE	

NOTES:

- ① MATERIAL:  
HOUSING: LCP  
CONTACT: COPPER ALLOY  
PLATING (CONTACT): Au OVER Ni.  
UL RATING: 94 V-0  
SOLDER BALL: (SEE TABLE) EUTECTIC SnPb OR LEADFREE 95.5 Sn/4Ag/0.5Cu
- ② SOLDER BALLS WILL NOT BE PERFECT SPHERICAL SHAPE DUE TO REFLOW ATTACHMENT.
- ③ MATED HEIGHT EFFECTED BY CUSTOMERS' PCB PAD SIZE, PLATING, SOLDER REFLOW PROFILE & SOLDER PASTE.
- ④ CONTACTS IN ROWS A,C,E,G,J,K,M,P,R AND T ARE SINGLE BEAM CONTACTS, TYPICALLY USED AS GROUND PINS. (NOTE: CONTACTS IN ROWS J & K ARE TIED TOGETHER [COMMONED])
- ⑤ CONTACTS IN ROWS B,D,F,H,L,N,Q AND S ARE DUAL BEAM CONTACTS, TYPICALLY USED AS SIGNAL PINS.

NOTES CONTINUED

- ⑥ SPECIFIED POSITIONAL TOLERANCE DEFINES PAD TO PAD LOCATION WITHIN LAND PATTERN. POSITIONAL TOLERANCE OF LAND PATTERN TO FUDICIAL MARKS OR PCB DATUMS SHALL BE DEFINED BY CUSTOMER. FOR RECOMMENDED PRODUCT APPLICATION AND PCB DESIGN DETAILS, SEE DOC. NO. GS-20-016.
- ⑦ FOR PROPER APPLICATION FOLLOW FCI APPLICATION SPECIFICATION GS-20-033 LEADFREE SOLDER BALLS WILL NOT SOLDER PROPERLY IN A LEADED SOLDER PROCESS DUE TO A HIGHER REFLOW TEMPERATURE, LEADFREE PRODUCT IS THEREFORE NOT BACKWARDS COMPATIBLE WITH LEADED OR SOME SOLDERING APPLICATIONS. REFERENCE FCI APPLICATION SPECIFICATION.
- ⑧ THIS PRODUCT MEETS THE EUROPEAN UNION DIRECTIVES AND OTHER COUNTRY REGULATIONS AS DESCRIBED IN GS-22-008. PRODUCT MEETING WITH THES DIRECTIVE IS IDENTIFIED IN THE LOT CODE NUMBER MARKED ON EACH PART BY HAVING AN "X" IN THE SEVENTH CHARACTER POSITION.



Copyright FCI.

spec ref	-			dr	Louis Ng	2010/11/01	projection 	mm 	size	A4	scale	1:1	
tolerance std	TOLERANCES UNLESS OTHERWISE SPECIFIED			eng	Nickor Zuo	2011/06/24			ecn no	ELX-DG-003943-1			
-				chr	Alex Cao	2011/06/24				rel level	Released		
-				appr	Pei-Ming Zheng	2011/06/27			product family		GIG-Array		
surface $\sqrt{3.2}$	linear	0.X	$\pm 0.30$			title	GIG-Array		dwg no	10008026		rev	D
		0.XX	$\pm 0.10$				13mm PLUG ASSY. 296 SIG. POS.						
		0.XXX	$\pm 0.05$										
ASME Y14.5	angular	0°	$\pm 2°$		www.fci.com	cat. no.	-	Product - Customer Drw		sheet 5 of 5			