



MICROCHIP

Explorer 16 Development Board User's Guide

Note the following details of the code protection feature on Microchip devices:

- Microchip products meet the specification contained in their particular Microchip Data Sheet.
- Microchip believes that its family of products is one of the most secure families of its kind on the market today, when used in the intended manner and under normal conditions.
- There are dishonest and possibly illegal methods used to breach the code protection feature. All of these methods, to our knowledge, require using the Microchip products in a manner outside the operating specifications contained in Microchip's Data Sheets. Most likely, the person doing so is engaged in theft of intellectual property.
- Microchip is willing to work with the customer who is concerned about the integrity of their code.
- Neither Microchip nor any other semiconductor manufacturer can guarantee the security of their code. Code protection does not mean that we are guaranteeing the product as "unbreakable."

Code protection is constantly evolving. We at Microchip are committed to continuously improving the code protection features of our products. Attempts to break Microchip's code protection feature may be a violation of the Digital Millennium Copyright Act. If such acts allow unauthorized access to your software or other copyrighted work, you may have a right to sue for relief under that Act.

Information contained in this publication regarding device applications and the like is provided only for your convenience and may be superseded by updates. It is your responsibility to ensure that your application meets with your specifications. MICROCHIP MAKES NO REPRESENTATIONS OR WARRANTIES OF ANY KIND WHETHER EXPRESS OR IMPLIED, WRITTEN OR ORAL, STATUTORY OR OTHERWISE, RELATED TO THE INFORMATION, INCLUDING BUT NOT LIMITED TO ITS CONDITION, QUALITY, PERFORMANCE, MERCHANTABILITY OR FITNESS FOR PURPOSE. Microchip disclaims all liability arising from this information and its use. Use of Microchip devices in life support and/or safety applications is entirely at the buyer's risk, and the buyer agrees to defend, indemnify and hold harmless Microchip from any and all damages, claims, suits, or expenses resulting from such use. No licenses are conveyed, implicitly or otherwise, under any Microchip intellectual property rights.

Trademarks

The Microchip name and logo, the Microchip logo, dsPIC, FlashFlex, KEELOQ, KEELOQ logo, MPLAB, PIC, PICmicro, PICSTART, PIC³² logo, rPIC, SST, SST Logo, SuperFlash and UNI/O are registered trademarks of Microchip Technology Incorporated in the U.S.A. and other countries.

FilterLab, Hampshire, HI-TECH C, Linear Active Thermistor, MTP, SEEVAL and The Embedded Control Solutions Company are registered trademarks of Microchip Technology Incorporated in the U.S.A.

Silicon Storage Technology is a registered trademark of Microchip Technology Inc. in other countries.

Analog-for-the-Digital Age, Application Maestro, BodyCom, chipKIT, chipKIT logo, CodeGuard, dsPICDEM, dsPICDEM.net, dsPICworks, dsSPEAK, ECAN, ECONOMONITOR, FanSense, HI-TIDE, In-Circuit Serial Programming, ICSP, Mindi, MiWi, MPASM, MPF, MPLAB Certified logo, MPLIB, MPLINK, mTouch, Omniscent Code Generation, PICC, PICC-18, PICDEM, PICDEM.net, PICkit, PICtail, REAL ICE, rLAB, Select Mode, SQI, Serial Quad I/O, Total Endurance, TSHARC, UniWinDriver, WiperLock, ZENA and Z-Scale are trademarks of Microchip Technology Incorporated in the U.S.A. and other countries.

SQTP is a service mark of Microchip Technology Incorporated in the U.S.A.

GestIC and ULPP are registered trademarks of Microchip Technology Germany II GmbH & Co. KG, a subsidiary of Microchip Technology Inc., in other countries.

All other trademarks mentioned herein are property of their respective companies.

© 2005-2014, Microchip Technology Incorporated, Printed in the U.S.A., All Rights Reserved.

 Printed on recycled paper.

ISBN: 978-1-62077-795-4

**QUALITY MANAGEMENT SYSTEM
CERTIFIED BY DNV
= ISO/TS 16949 =**

Microchip received ISO/TS-16949:2009 certification for its worldwide headquarters, design and wafer fabrication facilities in Chandler and Tempe, Arizona; Gresham, Oregon and design centers in California and India. The Company's quality system processes and procedures are for its PIC[®] MCUs and dsPIC[®] DSCs, KEELOQ[®] code hopping devices, Serial EEPROMs, microperipherals, nonvolatile memory and analog products. In addition, Microchip's quality system for the design and manufacture of development systems is ISO 9001:2000 certified.

Object of Declaration:

EU Declaration of Conformity

This declaration of conformity is issued by the manufacturer.

The development/evaluation tool is designed to be used for research and development in a laboratory environment. This development/evaluation tool is not a Finished Appliance, nor is it intended for incorporation into Finished Appliances that are made commercially available as single functional units to end users under EU EMC Directive 2004/108/EC and as supported by the European Commission's Guide for the EMC Directive 2004/108/EC (8th February 2010).

This development/evaluation tool complies with EU RoHS2 Directive 2011/65/EU.

For information regarding the exclusive, limited warranties applicable to Microchip products, please see Microchip's standard terms and conditions of sale, which are printed on our sales documentation and available at www.microchip.com.

Signed for and on behalf of Microchip Technology Inc. at Chandler, Arizona, USA

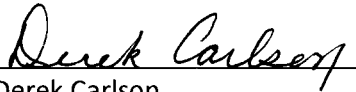

Derek Carlson

VP Development Tools

16-July-2013

Date

Explorer 16 Development Board

NOTES:



EXPLORER 16 DEVELOPMENT BOARD USER'S GUIDE

Table of Contents

Preface	7
Chapter 1. Introducing the Explorer 16 Development Board	
1.1 Introduction	11
1.2 Highlights	11
1.3 What's in the Kit	11
1.4 Explorer 16 Development Board Functionality and Features	12
1.5 Using the Explorer 16 Out of the Box	14
1.6 Explorer 16 Development Board Demonstration Programs	14
1.7 Reference Documents	14
Chapter 2. Explorer 16 Development Hardware	
2.1 Introduction	15
2.2 Hardware Features	15
Appendix A. Explorer 16 Development Board Schematics	
A.1 Introduction	19
A.2 Development Board Block Diagram	19
A.3 Development Board Schematics	20
Index	29
Worldwide Sales and Service	30

Explorer 16 Development Board

NOTES:

Preface

NOTICE TO CUSTOMERS

All documentation becomes dated, and this manual is no exception. Microchip tools and documentation are constantly evolving to meet customer needs, so some actual dialogs and/or tool descriptions may differ from those in this document. Please refer to our web site (www.microchip.com) to obtain the latest documentation available.

Documents are identified with a “DS” number. This number is located on the bottom of each page, in front of the page number. The numbering convention for the DS number is “DSXXXXXXXXA”, where “XXXXXXXX” is the document number and “A” is the revision level of the document.

For the most up-to-date information on development tools, see the MPLAB® IDE on-line help. Select the Help menu, and then Topics to open a list of available on-line help files.

INTRODUCTION

This chapter contains general information that will be useful to know before using the Explorer 16 Development Board. Items discussed in this chapter include:

- [Document Layout](#)
- [Conventions Used in this Guide](#)
- [Warranty Registration](#)
- [Recommended Reading](#)
- [The Microchip Web Site](#)
- [Product Change Notification Service](#)
- [Customer Support](#)
- [Document Revision History](#)

DOCUMENT LAYOUT

This document describes how to use the Explorer 16 Development Board as a development tool to emulate and debug firmware on a target board. The manual layout is as follows:

- **Chapter 1. “Introducing the Explorer 16 Development Board”** provides a brief overview of the Explorer 16 Development Board, its features and its uses.
- **Chapter 2. “Explorer 16 Development Hardware”** provides a more detailed description of the Explorer 16 board’s hardware features.
- **Appendix A. “Explorer 16 Development Board Schematics”** provides a block diagram and detailed schematics of the Explorer 16 board.

Explorer 16 Development Board

CONVENTIONS USED IN THIS GUIDE

This manual uses the following documentation conventions:

DOCUMENTATION CONVENTIONS

Description	Represents	Examples
Arial font:		
Italic characters	Referenced books	<i>MPLAB® IDE User's Guide</i>
	Emphasized text	...is the <i>only</i> compiler...
Initial caps	A window	the Output window
	A dialog	the Settings dialog
	A menu selection	select Enable Programmer
Quotes	A field name in a window or dialog	"Save project before build"
Underlined, italic text with right angle bracket	A menu path	<u><i>File>Save</i></u>
Bold characters	A dialog button	Click OK
	A tab	Click the Power tab
Text in angle brackets < >	A key on the keyboard	Press <Enter>, <F1>
Courier New font:		
Plain Courier New	Sample source code	#define START
	Filenames	autoexec.bat
	File paths	c:\mcc18\h
	Keywords	_asm, _endasm, static
	Command-line options	-Opa+, -Opa-
	Bit values	0, 1
	Constants (in source code)	0xFF, 'A'
Italic Courier New	A variable argument	<i>file.o</i> , where <i>file</i> can be any valid filename
Square brackets []	Optional arguments	mcc18 [options] <i>file</i> [options]
Curly brackets and pipe character: { }	Choice of mutually exclusive arguments; an OR selection	errorlevel {0 1}
Ellipses...	Replaces repeated text	var_name [, var_name...]
	Represents code supplied by user	void main (void) { ... }

WARRANTY REGISTRATION

Please complete the enclosed Warranty Registration Card and mail it promptly. Sending in the Warranty Registration Card entitles users to receive new product updates. Interim software releases are available at the Microchip web site.

RECOMMENDED READING

This user's guide describes how to use the Explorer 16 Development Board. Other useful documents are listed below. The following Microchip documents are available and recommended as supplemental reference resources.

Explorer 16 Development Board Product Page

For the latest information for the Explorer 16 Development board, please visit:
www.microchip.com/explorer16

PIC24FJ128GA010 Family Data Sheet (DS39747)

Consult this document for detailed information on the PIC24F general purpose, 16-bit devices. Reference information found in this data sheet includes:

- Device memory map
- Device pinout and packaging details
- Device electrical specifications
- List of peripherals included on the device

dsPIC33FJXXXGPX06A/X08A/X10A Family Data Sheet (DS70593)

Consult this document for detailed information on the dsPIC33FJXXXGPX06A/X08A/X10A Digital Signal Controllers. Reference information found in this data sheet includes:

- Device memory map
- Device pinout and packaging details
- Device electrical specifications
- List of peripherals included on the device

16-Bit MCU and DSC Programmer's Reference Manual (DS70157)

This manual is a software developer's reference for all of Microchip's 16-bit devices. It describes the instruction set in detail and also provides general information to assist in developing software.

Additional 16-Bit Families

Information about other 16-bit families can be found at:

www.microchip.com/16bit

MPLAB[®] XC16 C Compiler User's Guide (DS50002071)

Consult this document for detailed information on Microchip's MPLAB XC16 C Compiler for 16-bit devices to develop an application. Please visit www.microchip.com/compilers for more information.

MPLAB[®] X IDE User's Guide (DS52027)

This document details the use of the MPLAB X Integrated Development Environment (IDE). It also contains tutorials on how to create a new project, build, program and debug. Please visit www.microchip.com/mplabx for more information.

Explorer 16 Development Board

THE MICROCHIP WEB SITE

Microchip provides online support via our web site at www.microchip.com. This web site is used as a means to make files and information easily available to customers. The web site contains the following information:

- **Product Support** – Data sheets and errata, application notes and sample programs, design resources, user's guides and hardware support documents, latest software releases and archived software
- **General Technical Support** – Frequently Asked Questions (FAQs), technical support requests, online discussion groups, Microchip consultant program member listing
- **Business of Microchip** – Product selector and ordering guides, latest Microchip press releases, listing of seminars and events, listings of Microchip sales offices, distributors and factory representatives

PRODUCT CHANGE NOTIFICATION SERVICE

Microchip's customer notification service helps keep customers current on Microchip products. Subscribers will receive e-mail notification whenever there are changes, updates, revisions or errata related to a specified product family or development tool of interest.

To register, access the Microchip web site at www.microchip.com, click on Product Change Notification and follow the registration instructions.

CUSTOMER SUPPORT

Users of Microchip products can receive assistance through several channels:

- Distributor or Representative
- Local Sales Office
- Field Application Engineer (FAE)
- Technical Support
- Development Systems Information Line

Customers should contact their distributor, representative or field application engineer (FAE) for support. Local sales offices are also available to help customers. A listing of sales offices and locations is included in the back of this document.

Technical support is available through the web site at:
<http://support.microchip.com>

DOCUMENT REVISION HISTORY

Revision A (November 2005)

This is the initial release of this Document.

Revision B (January 2014)

Added updated information regarding the current versions of MPLAB XC16 C Compiler and MPLAB X IDE.

Minor grammatical edits throughout the text.

Chapter 1. Introducing the Explorer 16 Development Board

1.1 INTRODUCTION

The Explorer 16 Development Board provides a low-cost, modular development system for Microchip's 16-bit and 32-bit microcontroller families.

As provided, the development board works as a demo board right from the box and also has the ability to extend its functionality through modular expansion interfaces. The Explorer 16 Development Board supports the MPLAB[®] programmer and debugger for full emulation and debug capabilities, and also allows 3V controllers to interface with 5V peripheral devices.

1.2 HIGHLIGHTS

This chapter covers the following topics:

- [What's in the Kit](#)
- [Explorer 16 Development Board Functionality and Features](#)
- [Using the Explorer 16 Out of the Box](#)
- [Explorer 16 Development Board Demonstration Programs](#)
- [Reference Documents](#)

1.3 WHAT'S IN THE KIT

The Explorer 16 Development Board Kit contains the following:

- The Explorer 16 Development Board
- Depending on the specific kit, one or several Processor Plug-In Module(s) (PIM)
- An RS-232 cable
- Please visit www.microchip.com/explorer16 to download the following:
 - This User's Guide
 - Schematics for the PIM modules
 - Example programs for use with the PIC[®] MCU and dsPIC[®] DSC devices.

Note: The Explorer 16 Development Board has been designed to allow function from a permanently mounted PIC24FJ128GA010 device at position, U1. Units are shipped with U1 unpopulated and a PIM mounted on the U1A headers instead. When using the PIM, it is critical to verify that switch, S2, always remains in the "PIM" position.

See [Section 2.2.1 "Processor Support"](#) for more information.

Explorer 16 Development Board

1.4 EXPLORER 16 DEVELOPMENT BOARD FUNCTIONALITY AND FEATURES

A layout of the Explorer 16 Development Board is shown in [Figure 1-1](#). The board includes these key features, as indicated in the diagram:

1. 100-pin PIM riser, compatible with the PIM versions of selected Microchip PIC MCU and dsPIC DSC devices
2. Direct 9 VDC power input that provides +3.3V and +5V (regulated) to the entire board
3. Power indicator LED
4. RS-232 serial port and associated hardware
5. On-board analog thermal sensor
6. [No longer supported] USB connectivity for communications and device programming/debugging
7. Standard, 6-wire In-Circuit Debugger (ICD) connector for connections to an MPLAB ICD programmer/debugger module
8. Hardware selection of PIM or soldered on-board microcontroller
9. 2-line by 16-character LCD
10. Provisioning on PCB for add on graphic LCD
11. Push button switches for device Reset and user-defined inputs
12. Potentiometer for analog input
13. Eight indicator LEDs
14. 74HCT4053 multiplexers for selectable crossover configuration on serial communication lines
15. Independent crystals for precision microcontroller clocking (8 MHz) and RTCC operation (32.768 kHz)
16. Serial EEPROM
17. Prototype area for developing custom applications
18. Socket and edge connector for PICtail™ Plus card compatibility
19. Six-pin interface for the PICKit™ Programmer
20. JTAG connector pad for optional boundary scan functionality

For additional details on these features, refer to [Chapter 2. “Explorer 16 Development Hardware”](#).

Introducing the Explorer 16 Development Board

FIGURE 1-1: EXPLORER 16 DEVELOPMENT BOARD LAYOUT

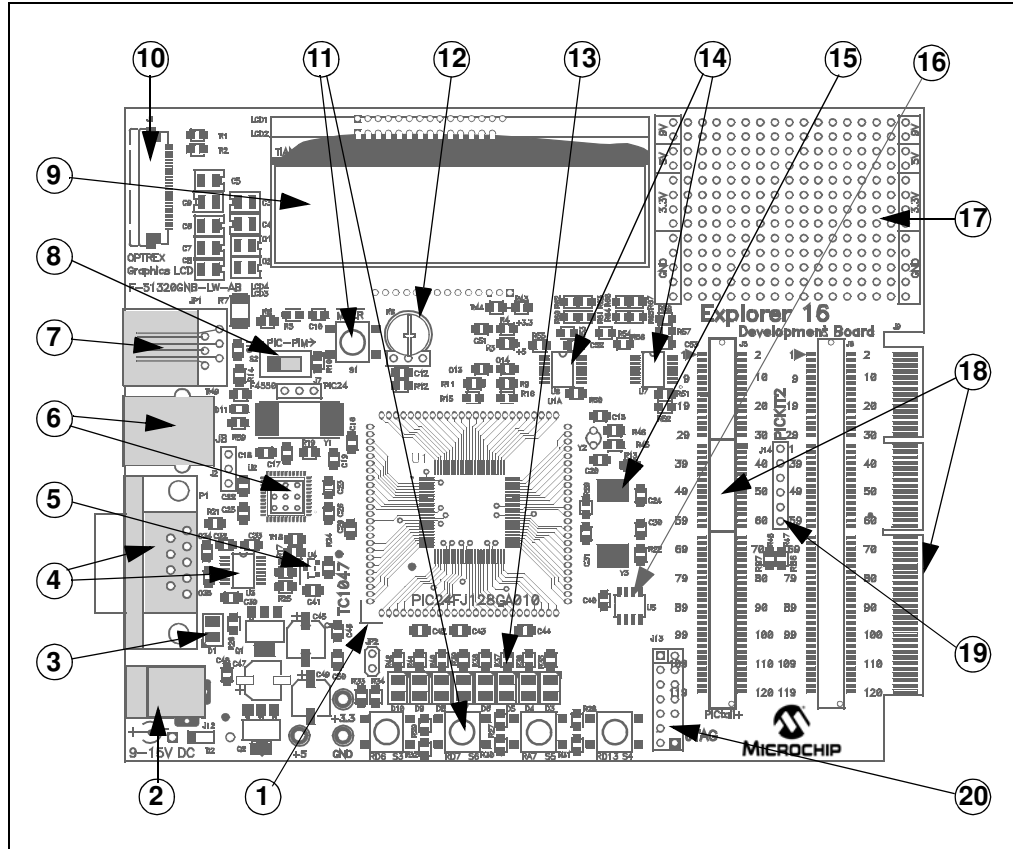

Explorer 16 Development Board

1.5 USING THE EXPLORER 16 OUT OF THE BOX

Although intended as a development platform, the Explorer 16 Development Board may also be used directly from the box as a demonstration board for PIC MCU and dsPIC DSC devices. The programs are preprogrammed into the sample device PIMs.

To get started with the board:

1. For Explorer 16 boards without a permanently mounted PIC24FJ device: Verify that a PIM is correctly installed onto the board. For all PIMs, be certain to align the PIM so the notched corner marking is oriented in the upper left corner.
2. For Explorer 16 boards without a permanently mounted PIC24FJ device: Verify that switch S2 is set in the “PIM” position.
For Explorer 16 boards with a permanently mounted PIC24FJ device: verify that switch, S2, is set in the “PIC” device position.
3. Verify that the jumper on JP2 is installed (to enable the LEDs).
4. Apply power to the board (9 VDC) at power input, J2. For information on acceptable power sources, see [Appendix A. “Explorer 16 Development Board Schematics”](#).

FIGURE 1-2: EXPLORER 16 PIM MODULE, SHOWING NOTCHED CORNER MARKING

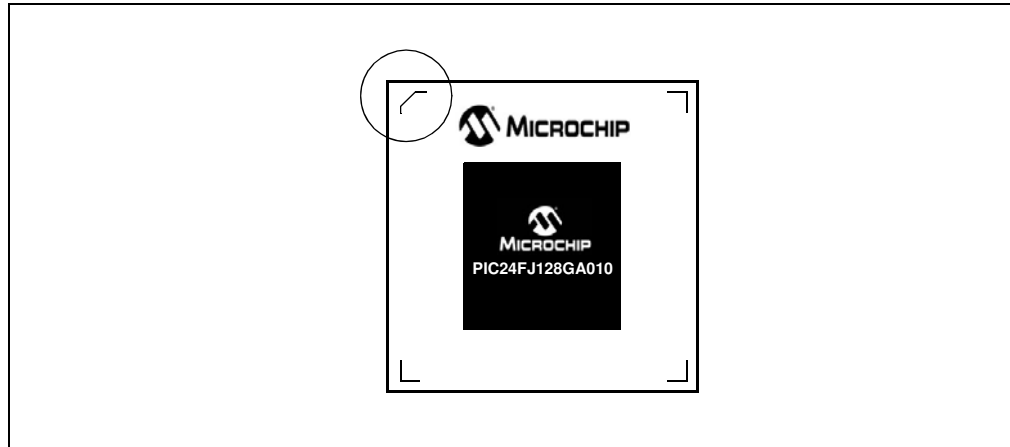

1.6 EXPLORER 16 DEVELOPMENT BOARD DEMONSTRATION PROGRAMS

Example code and MPLAB projects are available for download from www.microchip.com/explorer16

Refer to the Readme file distributed with the demo code package for details regarding demonstration code operation.

1.7 REFERENCE DOCUMENTS

In addition to the documents listed in the [“Recommended Reading”](#) section, these documents are also available from Microchip to support the use of the Explorer 16 Development Board:

- *PIC18F2455/2550/4455/4550 Data Sheet (DS39632)*
- *TC1047/TC1047A Data Sheet (DS21498)*
- *25AA256/25LC256 Data Sheet (DS21822)*

You can obtain these reference documents by downloading them from the Microchip web site (www.microchip.com).

Chapter 2. Explorer 16 Development Hardware

2.1 INTRODUCTION

This chapter provides a more detailed description of the hardware features of the Explorer 16 Development Board.

2.2 HARDWARE FEATURES

The key features of the Explorer 16 Development board are listed below. They are presented in the order given in [Section 1.4 “Explorer 16 Development Board Functionality and Features”](#), Figure 1-1.

Note: Pin names in this document apply to the PIC24FJ128GA010 device. When using any other device, obtain pin mapping from the PIM Information Sheet for that device.

2.2.1 Processor Support

The Explorer 16 board has been designed to accommodate both permanently mounted (i.e., soldered on) and detachable PIM processors. Slider switch, S2, allows the user to choose which processor to use. This makes it possible for the Explorer 16 board to support most 3V, pin compatible PIC[®] MCUs and dsPIC[®] DSCs with appropriate PIMs. PIMs are visually indexed for proper installation. The PIM is always installed with the notched corner mark on the corner of the PIM board oriented to the upper left corner. As shipped, the board does not have a permanently mounted microcontroller in U1. In order for the board to work, therefore, S2 must always be left in the “PIM” position.

2.2.2 Power Supply

There are two ways to supply power to the Explorer 16 board:

- An unregulated DC supply of 9V to 15V (preferably 9V) supplied to J12. For default functionality, a power supply with a current capability of 250 mA is sufficient. Since the board can serve as a modular development platform that can connect to multiple expansion boards, voltage regulators (Q1 and Q2) with a maximum current capability of 800 mA are used. This may require a larger power supply of up to 1.6A. Because the regulators do not have heat sinks, long-term operation at such loads is not recommended.

Note: The Explorer 16 kit does not include a power supply. If an external supply is needed, use Microchip part number: AC002014.

- An external, regulated DC power supply that provides both +5V and +3.3V can be connected to the terminals provided (at the bottom left side of the board, near S3).

One green LED (D1) is provided to show when the Explorer 16 board is powered up. The power-on LED indicates the presence of +3.3V.

Explorer 16 Development Board

2.2.3 RS-232 Serial Port

An RS-232 level shifter (U3) has been provided with all necessary hardware to support RS-232 connection with hardware flow control through the DB9 connector. The port is configured as a DCE device and can be connected to a PC using a straight-through cable.

The RX and TX pins are connected to the RX and TX lines of U3. The PIC and dsPIC device RTS and CTS pins are tied to the RX2 (DIN2) and TX2 (DOU2) lines of the MAX3232 for hardware flow control.

2.2.4 Temperature Sensor

An analog output thermal sensor (Microchip TC1074A, U4) is connected to one of the controller's A/D channels.

2.2.5 ICD Connector

An MPLAB programmer or debugger can be connected by way of the modular connector (JP1) for low-cost debugging. The ICD connector utilizes port pins, RB6 and RB7 of the microcontroller, for in-circuit debugging.

Jumper, J7, decides the terminus of the ICD connector. If the jumper is set to the "PIC24" side, JP1 communicates directly with PGCx/PGDx or EMUCx/EMUDx of the PIM or on-board device (determined by S2). If the jumper is set to the "F4450" side, JP1 communicates with the on-board PIC18LF4550 USB device.

2.2.6 LCD

The Explorer 16 board includes an alphanumeric LCD display with two lines of 16 characters each. The display is driven with three control lines and eight data lines. The LCD can be driven by the PMP module, if supported, or the I/O port.

An alternate configuration option allows the use of different I/O pins. To do this, the user must cut the trace jumpers at R60/62/64/66 and create solder bridges from the pads for R61/63/65/67 (see [Figure 2-1](#)).

FIGURE 2-1: MODIFICATIONS TO R60-R67 FOR LCD CONFIGURATION (SCALE ENHANCED FOR VISIBILITY)

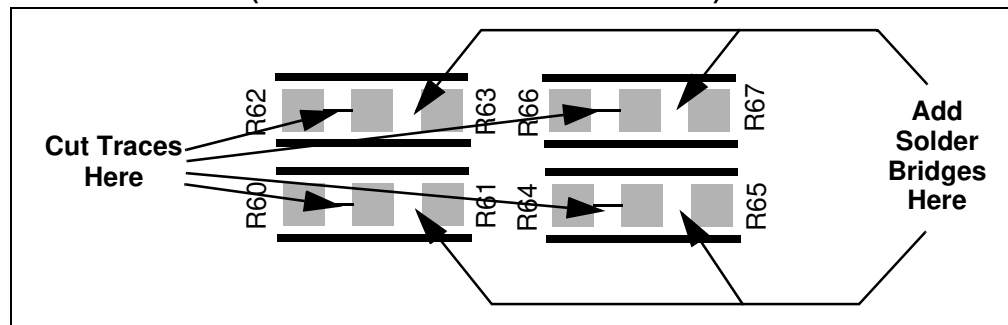

2.2.7 Graphic LCD

The Explorer 16 also has a footprint and layout support for the Optrex 128 x 64 dot-matrix graphic LCD (part number: F-51320GNB-LW-AB) and associated circuitry. This is the same display used in Microchip's MPLAB PM3 programmer.

2.2.8 Switches

Five push button switches provide the following functions:

- S1: Active-low $\overline{\text{MCLR}}$ switch to hard reset the processor
- S3: Active-low switch
- S4: Active-low switch
- S5: Active-low switch
- S6: Active-low switch

Switch, S1, has a debounce capacitor, whereas S3 through S6 do not; this allows the user to investigate debounce techniques. When Idle, the switches are pulled high (+3.3V); when pressed, they are grounded.

2.2.9 Analog Input (Potentiometer)

A 10 k Ω potentiometer is connected through a series resistor to AN5. It can be adjusted from VDD to GND to provide an analog input to one of the controller's A/D channels.

2.2.10 LEDs

Eight LEDs (D3 through D10) are available. Set the pins output high to light the LEDs. These LEDs may be disabled by removing jumper, JP2.

2.2.11 Oscillator Options

The installed microcontroller has two separate oscillator circuits connected. The main oscillator uses an 8 MHz crystal (Y3) and functions as the controller's primary oscillator. A second circuit, using a 32.768 kHz (watch type) crystal (Y2), functions as the Timer1 oscillator and serves as the source for the RTCC and secondary oscillator.

2.2.12 Serial EEPROM

A 25LC256 256K (32K x 8) serial EEPROM (U5) is included for nonvolatile firmware storage; it is also used to demonstrate SPI bus operation.

2.2.13 PICkit™ Programmer Connector

Connector, J14, provides the footprint for a 6-pin PICkit programmer interface.

2.2.14 JTAG Connector

Connector, J13, provides a standard JTAG interface, allowing users to connect to, and program the controller, via JTAG when supported.

2.2.15 PICtail™ Plus Card Edge Modular Expansion Connectors

The Explorer 16 board has been designed with the PICtail™ Plus modular expansion interface, allowing the board to provide basic generic functionality and still be easily extendable to new technologies as they become available.

PICtail Plus is based on a 120-pin connection, divided into three sections of 30 pins, 30 pins and 56 pins. The two 30-pin connections have parallel functionality. For example, Pins 1, 3, 5 and 7 have SPI1 functionality on the top 30-pin segment, with similar SPI2 functionality on the corresponding pins in the middle 30-pin segment.

Each 30-pin section provides connections to all of the serial communications peripherals, as well as many I/O ports, external interrupts and A/D channels. This provides enough signals to develop many different expansion interfaces, such as Ethernet, Zigbee®, IrDA® and so on. The 30-pin PICtail Plus expansion boards can be used in either the top or middle 30-pin sections.

Explorer 16 Development Board

The Explorer 16 board provides footprints for two edge connectors for daughter cards, one populated (J5, Samtec # MEC1-160-02-S-D-A) and one unpopulated (J6). The board also has a matching male edge connection (J9), allowing it to be used as an expansion card itself.

2.2.15.1 CROSSOVER CONNECTIONS FOR SPI AND UART

The PICTail Plus interface allows two Explorer 16 boards to be connected directly to each other without any external connector. This provides 1-to-1 connection between the microcontrollers on the two boards, an interface that works well for many types of peripherals (I²C™, PMP, etc.). However, certain serial peripheral modules, such as SPIs and UARTs, require cross-wire connections; that is, the TX (or SDO) pin of one controller must be connected to the RX (or SDI) of the other and vice versa.

The Explorer 16 board uses two 74HCT4053 analog multiplexers to simplify the connections between itself and any daughter boards. U6 and U7 provide active control of the cross-wire capability on SPI1 and UART1, with a hardware flow control signal provided by three I/O pins.

The multiplexers are controlled by the state of pins, RB12, RB13 and RB14. When a control pin is high (the default state), the corresponding SPI1 or UART1 pin pairs are connected to their default pins on the PICTail Plus interface. When a control pin is asserted low, the corresponding pin pair functions are swapped. [Table 2-1](#) details the relationship between the control pins and the SPI1/UART1 functions on the interface.

TABLE 2-1: LOCATION OF SPI1 AND UART1 PINS ON PICTail™ PLUS INTERFACE

Control Pin State	UART1 Control Pins				SPI1	
	Control Pin RB14		Control Pin RB13		Control Pin RB12	
	U1RX	U1TX	$\overline{\text{U1CTS}}$	$\overline{\text{U1RTS}}$	SDI1	SDO1
1	2	4	19	20	5	7
0	4	2	20	19	7	5

Note: When connecting SPI and UART peripherals on two Explorer 16 boards, use crossover connection on only one of the boards.

Appendix A. Explorer 16 Development Board Schematics

A.1 INTRODUCTION

This section provides detailed technical information on the Explorer 16 Development Board.

A.2 DEVELOPMENT BOARD BLOCK DIAGRAM

FIGURE A-1: HIGH-LEVEL BLOCK DIAGRAM OF THE EXPLORER 16 DEVELOPMENT BOARD

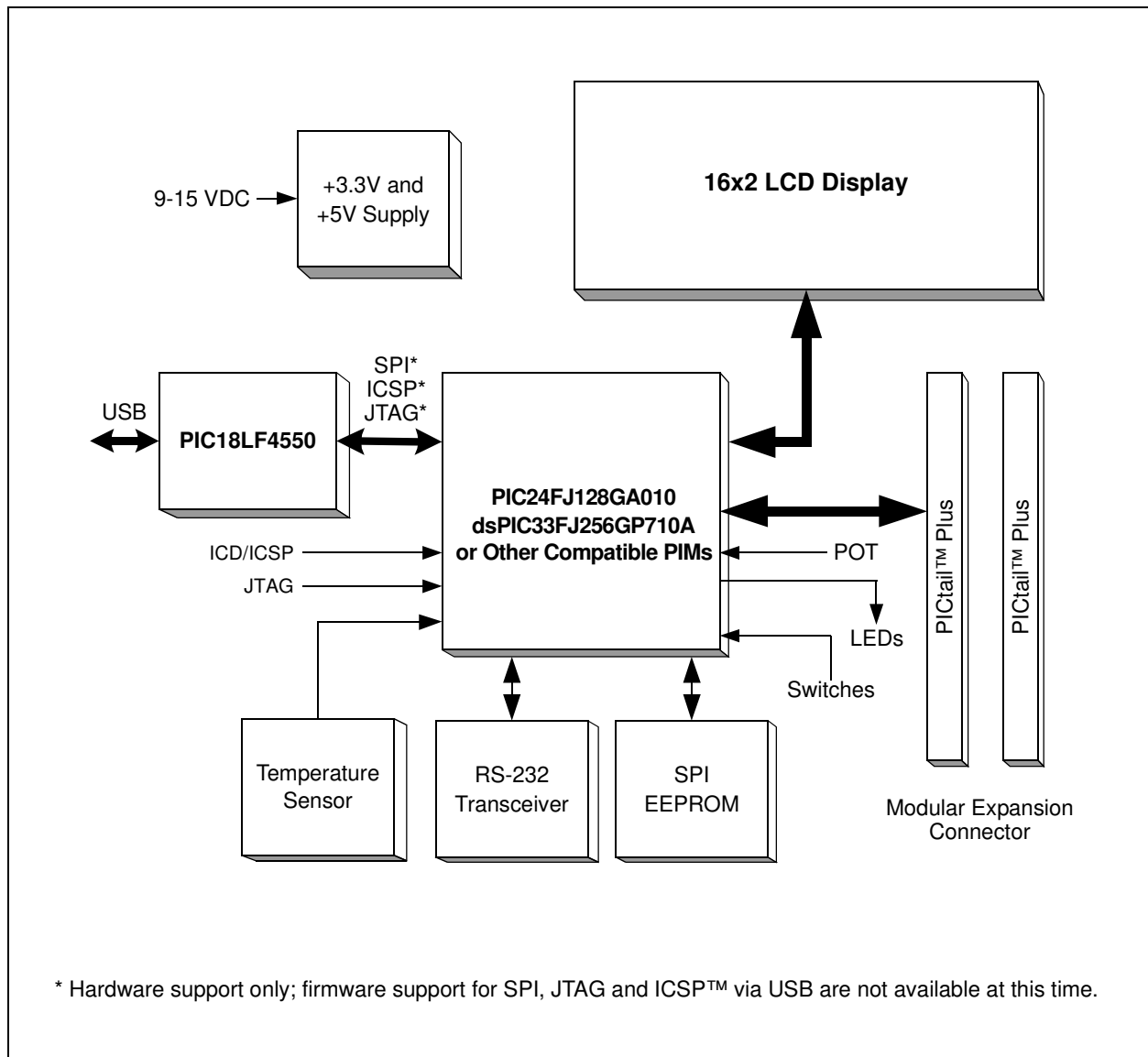

Explorer 16 Development Board

A.3 DEVELOPMENT BOARD SCHEMATICS

FIGURE A-2: EXPLORER 16 BOARD SCHEMATIC, SHEET 1 OF 8 (PIM SOCKET)

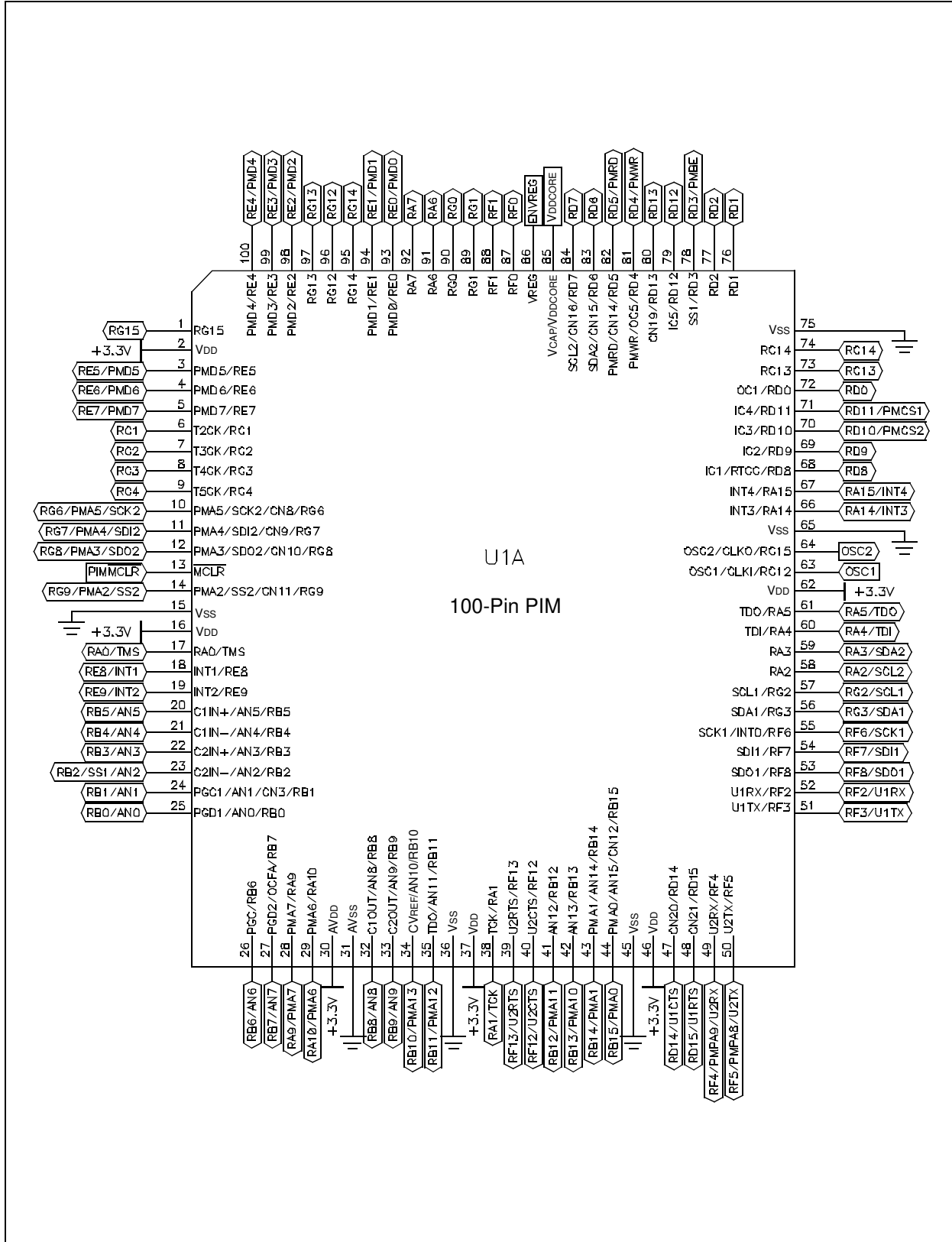

Explorer 16 Development Board

FIGURE A-4: EXPLORER 16 BOARD SCHEMATIC, SHEET 3 OF 8 (MPLAB® ICD, JTAG, PICKit™ PROGRAMMER AND PICTail™ Plus CONNECTORS)

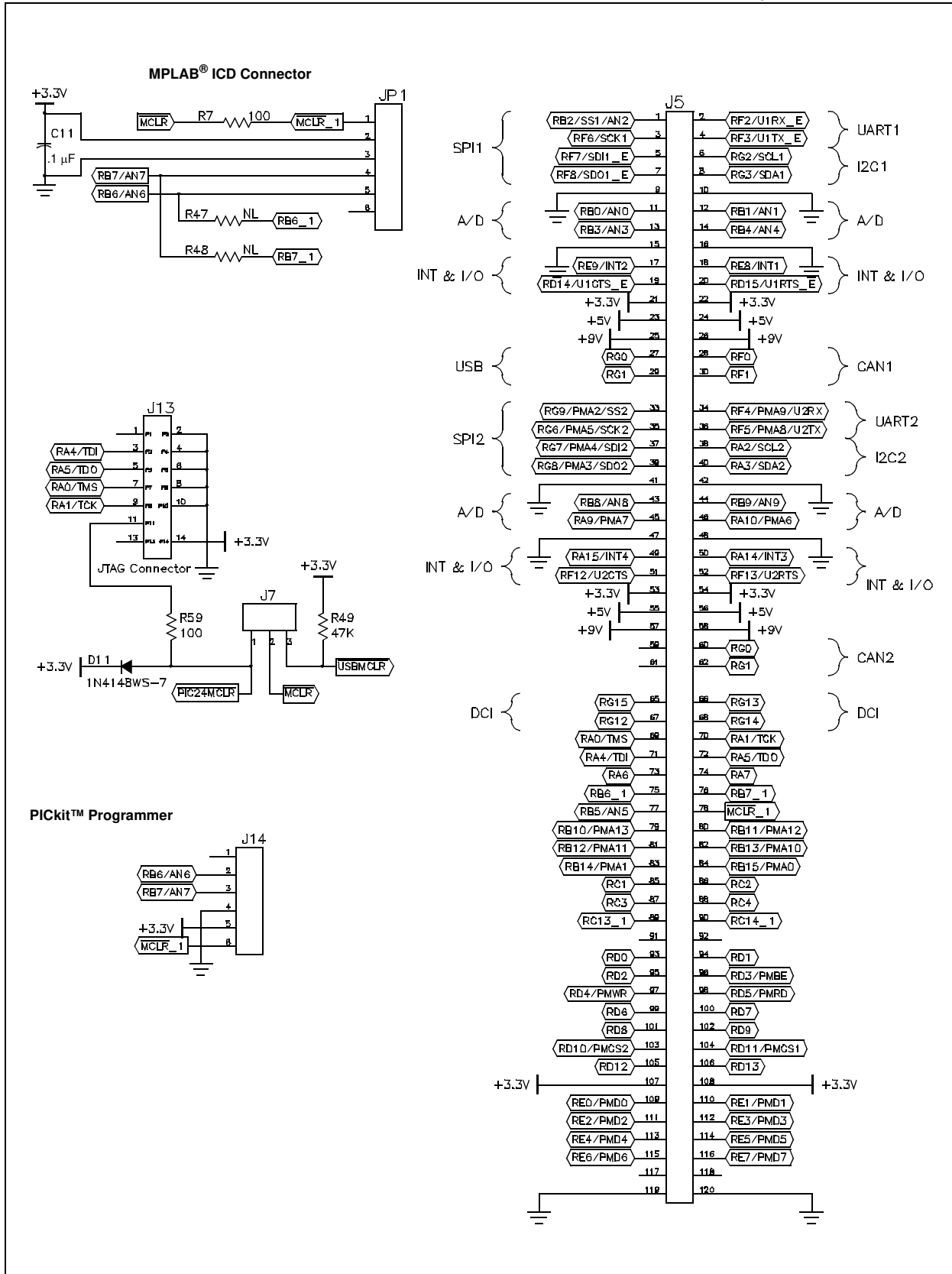

Explorer 16 Development Board Schematics

FIGURE A-5: EXPLORER 16 BOARD SCHEMATIC, SHEET 4 OF 8 (PICtail™ PLUS EDGE AND SOCKET CONNECTORS)

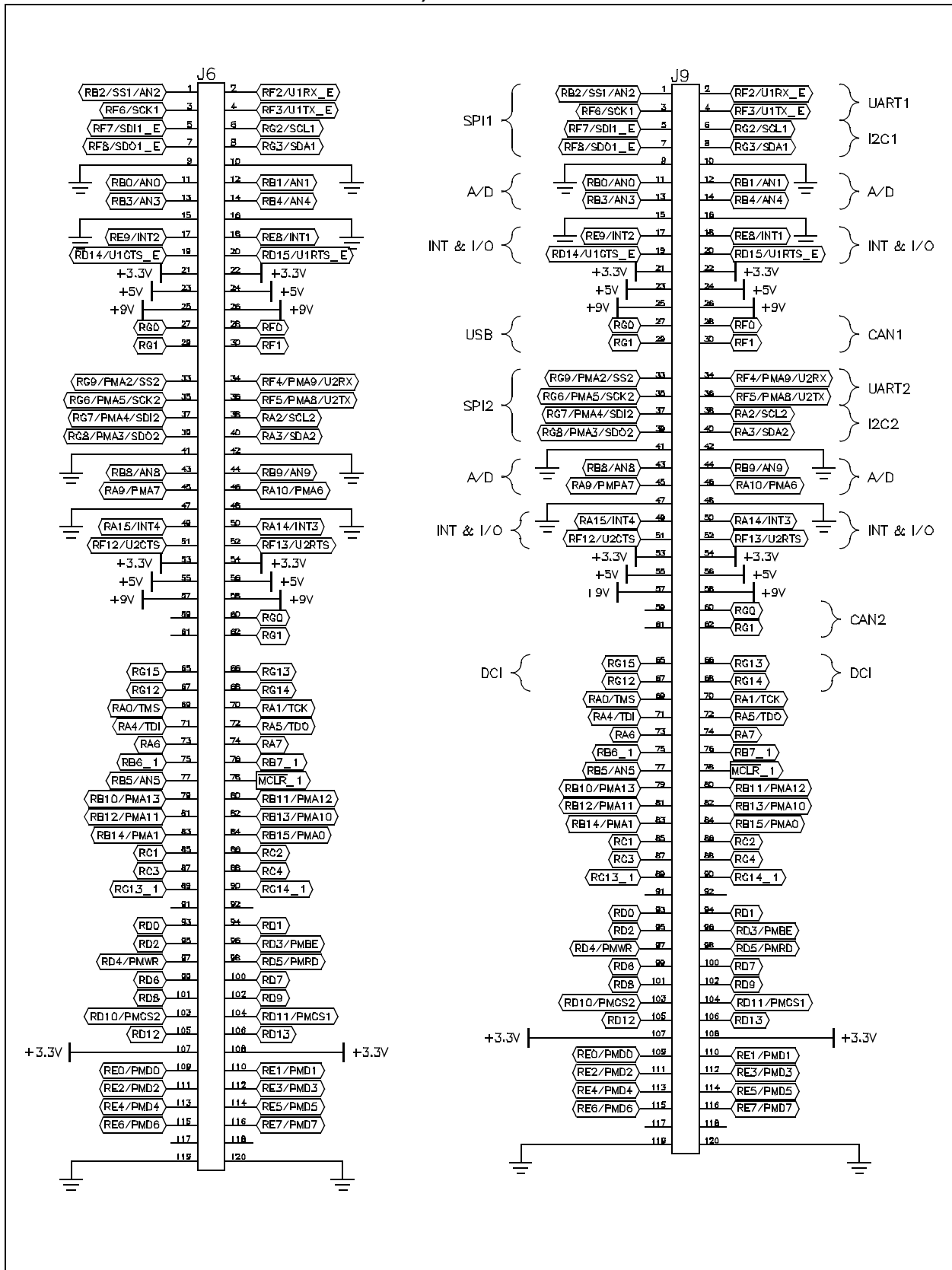

Explorer 16 Development Board

FIGURE A-6: EXPLORER 16 BOARD SCHEMATIC, SHEET 5 OF 8 (SWITCHES, MULTIPLEXERS AND POTENTIOMETER)

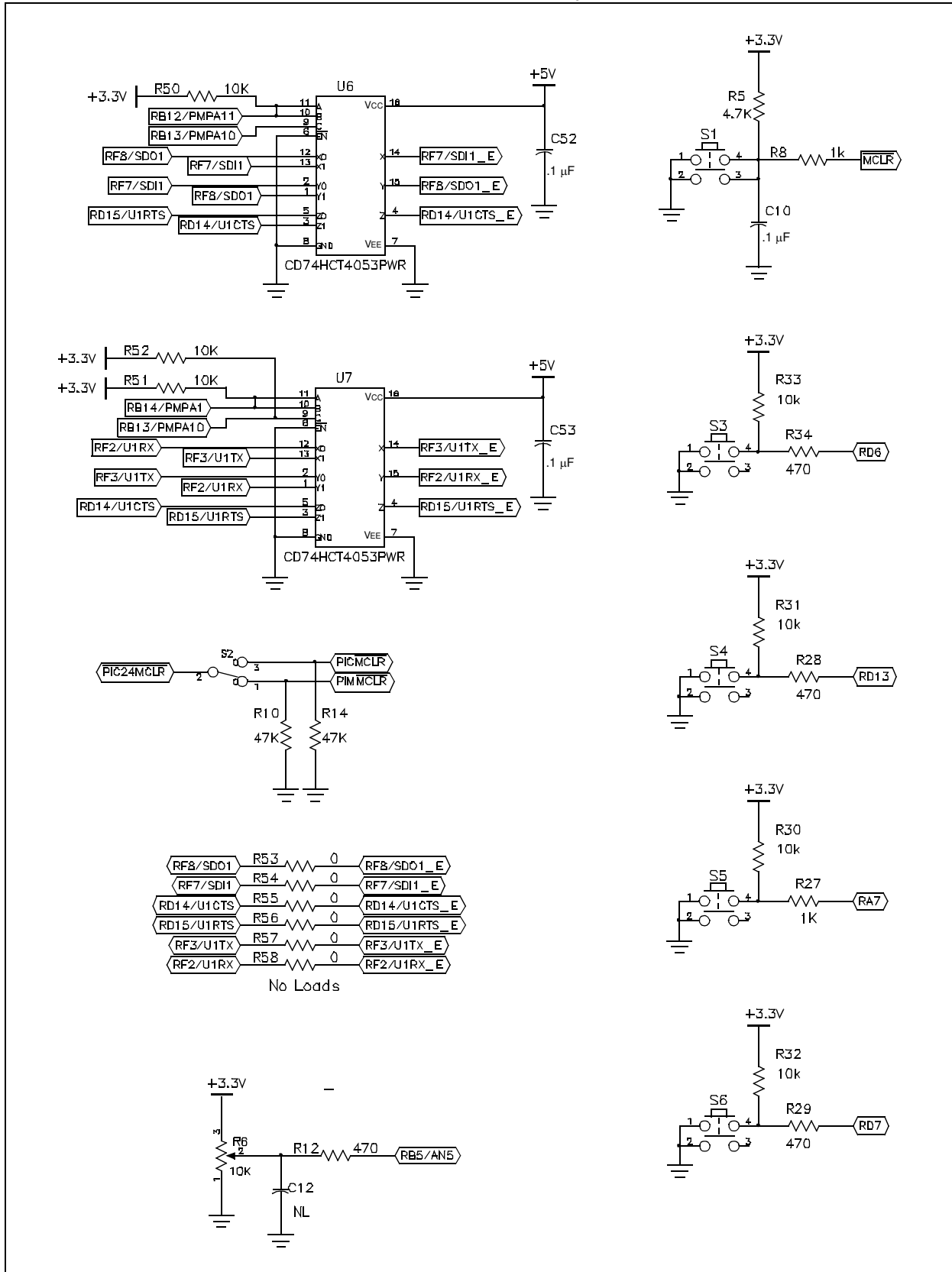

Explorer 16 Development Board Schematics

FIGURE A-7: EXPLORER 16 BOARD SCHEMATIC, SHEET 6 OF 8 (EEPROM, TEMPERATURE SENSOR, LEDs, OSCILLATOR CIRCUITS AND POWER SUPPLY)

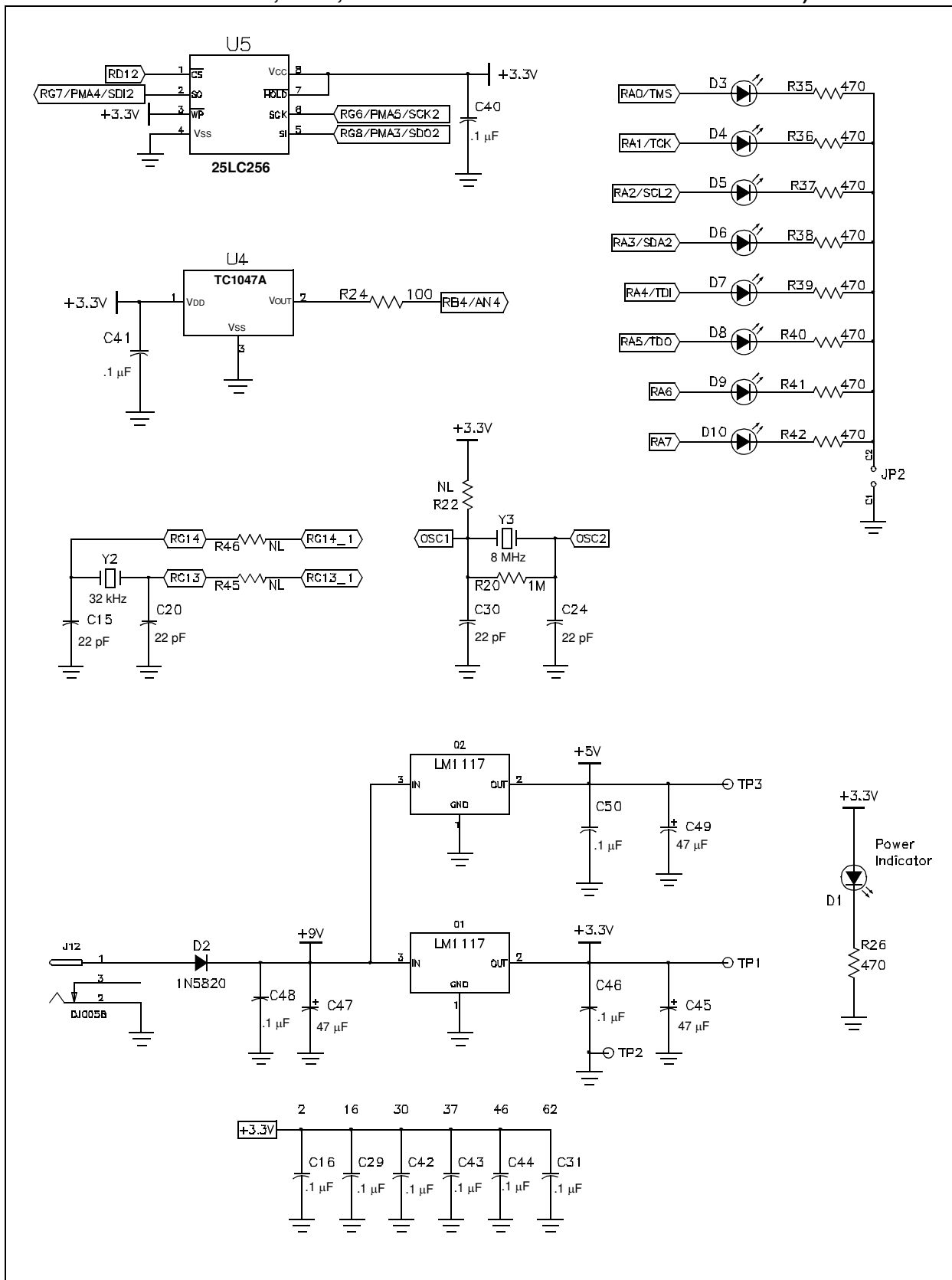

Explorer 16 Development Board Schematics

FIGURE A-9: EXPLORER 16 BOARD SCHEMATIC, SHEET 8 OF 8 (LCDs AND OPTIONAL LCD CONNECTIONS)

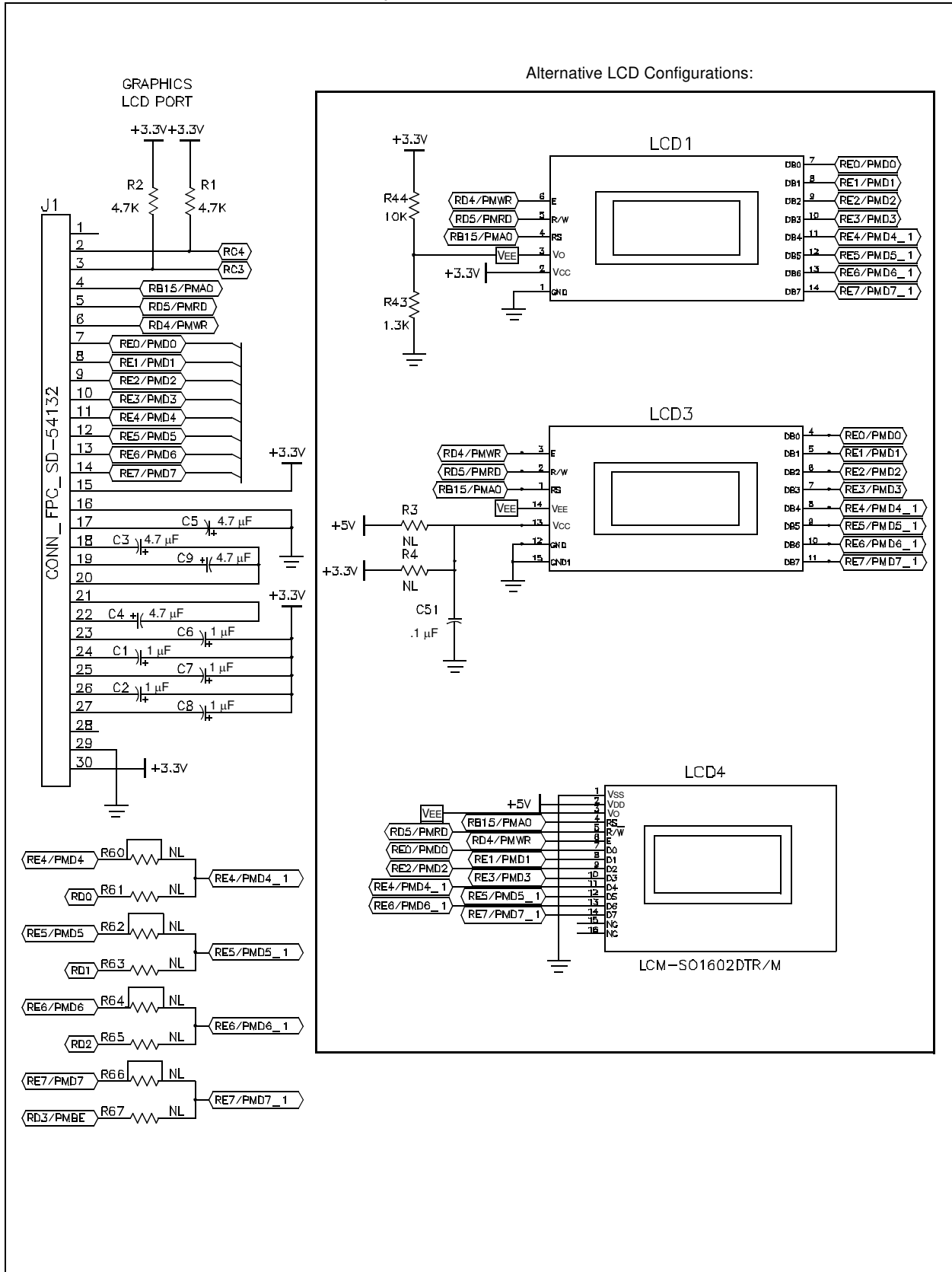

Explorer 16 Development Board

NOTES:



EXPLORER 16 DEVELOPMENT BOARD USER'S GUIDE

Index

A			
Additional 16-Bit Families.....	9		
C			
Crossover Connections (Serial Communications).....	18		
Customer Support.....	10		
D			
Documentation			
Conventions.....	8		
Layout.....	7		
dsPIC33FJXXXGPX06A/X08A/X10A Family			
Data Sheet.....	9		
E			
Explorer 16 Development Board			
Block Diagram.....	19		
Layout.....	13		
Schematics.....	20–27		
Explorer 16 Development Board Product Page.....	9		
H			
Hardware Features			
Analog Potentiometer.....	12, 17		
Crossover Connections			
(Serial Communications).....	12		
ICD Connector.....	12, 16		
JTAG Connector.....	12, 17		
LCD, Alphanumeric.....	12, 16		
LCD, Graphic.....	12, 16		
LEDs.....	12, 17		
Multiplexers.....	12, 18		
Oscillator Options.....	12, 17		
PICkit Programmer Connector.....	12, 17		
PICtail Plus Card Edge Connectors.....	12, 17		
Power Indicator LED.....	12		
Power Supply.....	12, 15		
Processor Support.....	12, 15		
Prototype Area.....	12		
RS-232 Serial Port.....	12, 16		
Serial EEPROM.....	12, 17		
Switches.....	12, 17		
Temperature Sensor.....	12, 16		
I			
Internet Address.....	10		
M			
Microchip Internet Web Site.....	10		
MPLAB X IDE User's Guide.....	9		
MPLAB XC16 C Compiler User's Guide.....	9		
P			
PIC24FJ128GA010 Family Data Sheet.....	9		
PICtail Plus Edge Connectors			
Use with Crossover Serial Connections.....	18		
Product Change Notification Service.....	10		
R			
Reading, Recommended.....	9		
Reference Documents.....	14		
Revision History.....	10		
S			
Schematics.....	20–27		
W			
Warranty Registration.....	8		
WWW Address.....	10		



MICROCHIP

Worldwide Sales and Service

AMERICAS

Corporate Office
2355 West Chandler Blvd.
Chandler, AZ 85224-6199
Tel: 480-792-7200
Fax: 480-792-7277
Technical Support:
<http://www.microchip.com/support>
Web Address:
www.microchip.com

Atlanta
Duluth, GA
Tel: 678-957-9614
Fax: 678-957-1455

Austin, TX
Tel: 512-257-3370

Boston
Westborough, MA
Tel: 774-760-0087
Fax: 774-760-0088

Chicago
Itasca, IL
Tel: 630-285-0071
Fax: 630-285-0075

Cleveland
Independence, OH
Tel: 216-447-0464
Fax: 216-447-0643

Dallas
Addison, TX
Tel: 972-818-7423
Fax: 972-818-2924

Detroit
Novi, MI
Tel: 248-848-4000

Houston, TX
Tel: 281-894-5983

Indianapolis
Noblesville, IN
Tel: 317-773-8323
Fax: 317-773-5453

Los Angeles
Mission Viejo, CA
Tel: 949-462-9523
Fax: 949-462-9608

New York, NY
Tel: 631-435-6000

San Jose, CA
Tel: 408-735-9110

Canada - Toronto
Tel: 905-673-0699
Fax: 905-673-6509

ASIA/PACIFIC

Asia Pacific Office
Suites 3707-14, 37th Floor
Tower 6, The Gateway
Harbour City, Kowloon
Hong Kong
Tel: 852-2401-1200
Fax: 852-2401-3431

Australia - Sydney
Tel: 61-2-9868-6733
Fax: 61-2-9868-6755

China - Beijing
Tel: 86-10-8569-7000
Fax: 86-10-8528-2104

China - Chengdu
Tel: 86-28-8665-5511
Fax: 86-28-8665-7889

China - Chongqing
Tel: 86-23-8980-9588
Fax: 86-23-8980-9500

China - Hangzhou
Tel: 86-571-2819-3187
Fax: 86-571-2819-3189

China - Hong Kong SAR
Tel: 852-2943-5100
Fax: 852-2401-3431

China - Nanjing
Tel: 86-25-8473-2460
Fax: 86-25-8473-2470

China - Qingdao
Tel: 86-532-8502-7355
Fax: 86-532-8502-7205

China - Shanghai
Tel: 86-21-5407-5533
Fax: 86-21-5407-5066

China - Shenyang
Tel: 86-24-2334-2829
Fax: 86-24-2334-2393

China - Shenzhen
Tel: 86-755-8864-2200
Fax: 86-755-8203-1760

China - Wuhan
Tel: 86-27-5980-5300
Fax: 86-27-5980-5118

China - Xian
Tel: 86-29-8833-7252
Fax: 86-29-8833-7256

China - Xiamen
Tel: 86-592-2388138
Fax: 86-592-2388130

China - Zhuhai
Tel: 86-756-3210040
Fax: 86-756-3210049

ASIA/PACIFIC

India - Bangalore
Tel: 91-80-3090-4444
Fax: 91-80-3090-4123

India - New Delhi
Tel: 91-11-4160-8631
Fax: 91-11-4160-8632

India - Pune
Tel: 91-20-3019-1500

Japan - Osaka
Tel: 81-6-6152-7160
Fax: 81-6-6152-9310

Japan - Tokyo
Tel: 81-3-6880-3770
Fax: 81-3-6880-3771

Korea - Daegu
Tel: 82-53-744-4301
Fax: 82-53-744-4302

Korea - Seoul
Tel: 82-2-554-7200
Fax: 82-2-558-5932 or
82-2-558-5934

Malaysia - Kuala Lumpur
Tel: 60-3-6201-9857
Fax: 60-3-6201-9859

Malaysia - Penang
Tel: 60-4-227-8870
Fax: 60-4-227-4068

Philippines - Manila
Tel: 63-2-634-9065
Fax: 63-2-634-9069

Singapore
Tel: 65-6334-8870
Fax: 65-6334-8850

Taiwan - Hsin Chu
Tel: 886-3-5778-366
Fax: 886-3-5770-955

Taiwan - Kaohsiung
Tel: 886-7-213-7830

Taiwan - Taipei
Tel: 886-2-2508-8600
Fax: 886-2-2508-0102

Thailand - Bangkok
Tel: 66-2-694-1351
Fax: 66-2-694-1350

EUROPE

Austria - Wels
Tel: 43-7242-2244-39
Fax: 43-7242-2244-393

Denmark - Copenhagen
Tel: 45-4450-2828
Fax: 45-4485-2829

France - Paris
Tel: 33-1-69-53-63-20
Fax: 33-1-69-30-90-79

Germany - Dusseldorf
Tel: 49-2129-3766400

Germany - Munich
Tel: 49-89-627-144-0
Fax: 49-89-627-144-44

Germany - Pforzheim
Tel: 49-7231-424750

Italy - Milan
Tel: 39-0331-742611
Fax: 39-0331-466781

Italy - Venice
Tel: 39-049-7625286

Netherlands - Drunen
Tel: 31-416-690399
Fax: 31-416-690340

Poland - Warsaw
Tel: 48-22-3325737

Spain - Madrid
Tel: 34-91-708-08-90
Fax: 34-91-708-08-91

Sweden - Stockholm
Tel: 46-8-5090-4654

UK - Wokingham
Tel: 44-118-921-5800
Fax: 44-118-921-5820

10/28/13