

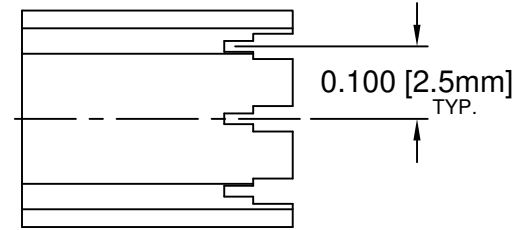

REV.	DESCRIPTION	DATE	APPROVED
A	Engineering Update w/o Changes	02/26/04	M. C.
B	Removed Material Code	05/28/16	J. C.

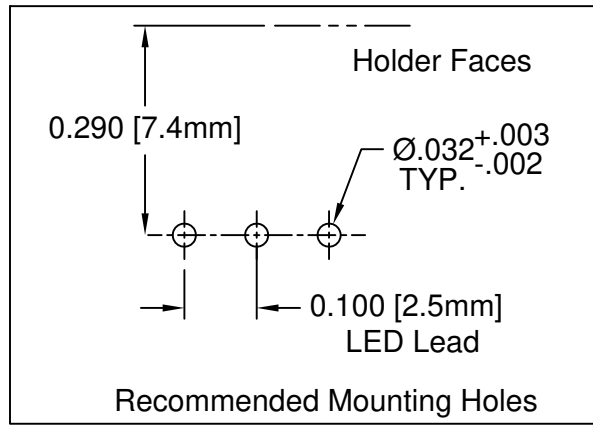
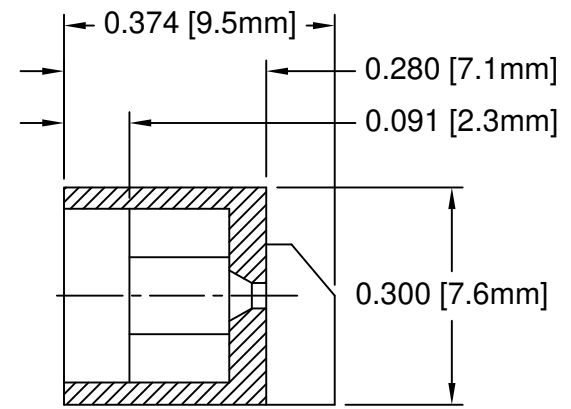
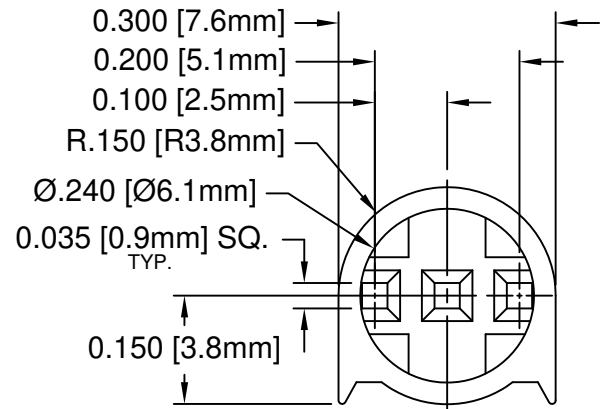
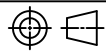

- 2. MATERIAL: NYLON 6/6, 94V-0, BLACK.
- 1. GENERAL SPECIFICATIONS: BIVAR MOLDED COMPONENT SPECIFICATION BV00-E101.

STANDARD TOLERANCE (UNLESS OTHERWISE SPECIFIED)		 4 THOMAS, IRVINE, CA. 92618 TEL: (949) 951-8808 FAX: (949) 951-3974	
DECIMALS	ANGULAR		
.X ± .1	X° ± 1°	 TITLE: T-1¼ (5mm) TRI-LEAD LED HOLDER	
.XX ± .01			PART NO: H-178C-3
.XXX ± .005			REVISION: B
DESIGNED: S. Irving	DATE: 02/08/99	CAGE CODE : 32559	SHEET # 1 OF 1
CHECKED: D. Green	DATE: 02/26/04	CAD GENERATED DOCUMENT. DO NOT MEASURE DRAWING.	