

## ISL99392R5935, ISL99392BR5935

### 90A Smart Power Stage (SPS) Module with Integrated High Accuracy Current and Master or Individual Temperature Monitors

The ISL99392R5935 and ISL99392BR5935 are 90A Smart Power Stages (SPS) that are compatible with Renesas ISL68/69xxx Digital Multiphase (DMP) controllers and phase doublers (ISL6617A), respectively. The ISL99392R5935 and ISL99392BR5935 offer best-in-class current sense accuracy over line, load, and temperature. When combined with a Renesas digital PWM controller (or doubler), these devices enable precision system level power management and best-in-class transient response for load-line based regulators. In addition to the common master TOUT signal to the DMP, the individual phase Temperature Reporting (TREF) supports thermal management and N+1 redundancy system management. The ISL99392R5935 and ISL99392BR5935 simplify design by eliminating typical DCR sensing networks and associated thermal compensation components. The thermally enhanced 5x6 package enables high density designs.

The ISL99392R5935 features the Renesas tri-state PWM input that works with the Renesas ISL682xx/ISL692xx digital multiphase PWM controllers to provide a robust solution in event of abnormal operating conditions. The ISL99392R5935 and ISL99392BR5935 also improve system performance and reliability with integrated fault protection, including HFET overcurrent, HFET shorted, Smart Reverse Overcurrent (SROCP), Over-Temperature (OTP), and  $V_{CC}$  Undervoltage Lockout (UVLO).

### Features

- $V_{IN}$  input range: +3.0V to +16V
- Supports 90A DC current
- 3.3V compatible tri-state PWM input (ISL99392R5935)
- 5V compatible tri-state PWM input (ISL99392BR5935)
- $\pm 3\%$  accuracy continuous signal for current monitor
- 8mV/°C master temperature monitor, TOUT
- 4mV/°C individual temperature monitor, TREF
- Comprehensive fault protection for high system reliability
  - High-side FET short and overcurrent protection
  - Smart Reverse Overcurrent Protection (SROCP)
  - Over-Temperature Protection (OTP)
  - $V_{CC}$  Undervoltage Lockout (UVLO)
- Fault reporting outputs
- Up to 1.25MHz switching frequency
- RoHS compliant, 5x6 PQFN

### Applications

- Accelerators (GPU, ASIC, artificial intelligence)
- Core, graphic, and memory VRs for microprocessors
- High density VR for server, networking, and cloud computing
- POL DC/DC converters and video gaming consoles

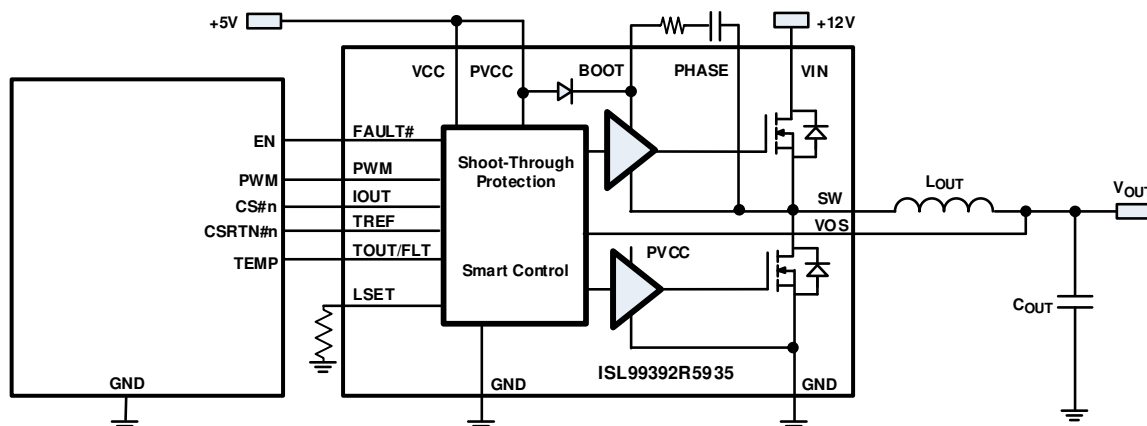

Figure 1. ISL99392R5935 Simplified Application Block Diagram

## IMPORTANT NOTICE AND DISCLAIMER

RENESAS ELECTRONICS CORPORATION AND ITS SUBSIDIARIES (“RENESAS”) PROVIDES TECHNICAL SPECIFICATIONS AND RELIABILITY DATA (INCLUDING DATASHEETS), DESIGN RESOURCES (INCLUDING REFERENCE DESIGNS), APPLICATION OR OTHER DESIGN ADVICE, WEB TOOLS, SAFETY INFORMATION, AND OTHER RESOURCES “AS IS” AND WITH ALL FAULTS, AND DISCLAIMS ALL WARRANTIES, EXPRESS OR IMPLIED, INCLUDING, WITHOUT LIMITATION, ANY IMPLIED WARRANTIES OF MERCHANTABILITY, FITNESS FOR A PARTICULAR PURPOSE, OR NON-INFRINGEMENT OF THIRD PARTY INTELLECTUAL PROPERTY RIGHTS.

These resources are intended for developers skilled in the art designing with Renesas products. You are solely responsible for (1) selecting the appropriate products for your application, (2) designing, validating, and testing your application, and (3) ensuring your application meets applicable standards, and any other safety, security, or other requirements. These resources are subject to change without notice. Renesas grants you permission to use these resources only for development of an application that uses Renesas products. Other reproduction or use of these resources is strictly prohibited. No license is granted to any other Renesas intellectual property or to any third party intellectual property. Renesas disclaims responsibility for, and you will fully indemnify Renesas and its representatives against, any claims, damages, costs, losses, or liabilities arising out of your use of these resources. Renesas' products are provided only subject to Renesas' Terms and Conditions of Sale or other applicable terms agreed to in writing. No use of any Renesas resources expands or otherwise alters any applicable warranties or warranty disclaimers for these products.

(Rev.1.0 Mar 2020)

### Corporate Headquarters

TOYOSU FORESIA, 3-2-24 Toyosu,  
Koto-ku, Tokyo 135-0061, Japan  
[www.renesas.com](http://www.renesas.com)

### Contact Information

For further information on a product, technology, the most up-to-date version of a document, or your nearest sales office, please visit:  
[www.renesas.com/contact/](http://www.renesas.com/contact/)

### Trademarks

Renesas and the Renesas logo are trademarks of Renesas Electronics Corporation. All trademarks and registered trademarks are the property of their respective owners.