

### ● Features:

1. Input power: 2W.
2. Chip material: AlGaAs.
3. High lumen output.
4. High flux density.
5. Low power consumption.
6. Efficient heat transfer.
7. Exterior lens is silicon.
8. Add extra heat sink is necessary.

### ● Applications:

1. Remote Control.
2. Smoke Detector.
3. Photo Detector.
4. Automatic Control System.
5. Infrared lighting.

### ● Package dimensions :

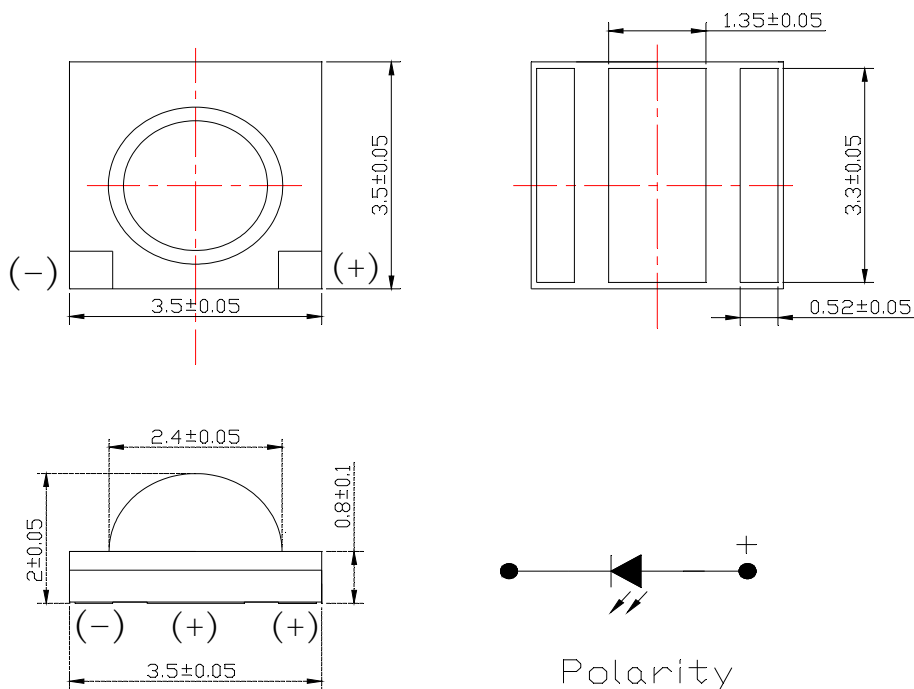

#### Notes:

1. All dimensions are in millimeters.
2. Tolerance is  $\pm 0.25$ mm unless otherwise specified.

● **Absolute maximum ratings ( $T_a=25^{\circ}\text{C}$ )**

Parameter	Symbol	Rating	Unit
Power Dissipation	$P_D$	2.0	W
DC Forward Current* <sup>1</sup>	$I_F$	1000	mA
Peak Pulsed Forward Current*	$I_{FP}$	1.5	A
LED Junction Temperature	$T_J$	115	$^{\circ}\text{C}$
Operating Temperature	$T_{opr}$	-40~ +85	$^{\circ}\text{C}$
Storage Temperature	$T_{stg}$	-40~ +100	$^{\circ}\text{C}$
Reverse Voltage	$V_R$	5	V
Manual Soldering (T=5 sec)	$T_{sol}$	$350 \pm 5$	$^{\circ}\text{C}$

\*Condition for  $I_{FP}$  is pulsed with 1/10 duty and 0.1msec width.

● **Electrical & Optical Characteristics ( $T_a=25^{\circ}\text{C}$ )**

Parameter	Symbol	Condition	Min.	Typ.	Max.	Unit
Forward Voltage	$V_F$	$I_F = 1000\text{mA}$	-	1.7	2.2	V
Radiant Power	$P_o$	$I_F = 1000\text{mA}$	585	780	-	mW
Radiant Intensity	$I_e$	$I_F=1000\text{mA}$	-	260	-	mW/sr
Peak Wavelength	$\lambda_p$	$I_F = 1000\text{mA}$	-	850	-	nm
Spectral Line Half-width	$\Delta \lambda$	$I_F = 1000\text{mA}$	-	40	-	nm
Reverse Current	$I_R$	$V_R = 5\text{V}$	-	-	5	$\mu\text{A}$
Rise/Fall Time PW=10uS DC=1%	$T_r$	$I_F = 1000\text{mA}$	-	500	-	ns
Rise/Fall Time PW=10uS DC=1%	$T_f$	$I_F = 1000\text{mA}$	-	200	-	ns
Thermal Resistance, Junction To Case	$R_{\theta_{J-C}}$	$I_F = 1000\text{mA}$	-	9	-	$^{\circ}\text{C}/\text{W}$
Viewing Angle	$2\theta_{1/2}$	$I_F = 1000\text{mA}$	-	120	-	degree

### ● Typical electro-optical characteristics curves

Fig.1 RELATIVE INTENSITY VS. WAVELENGTH

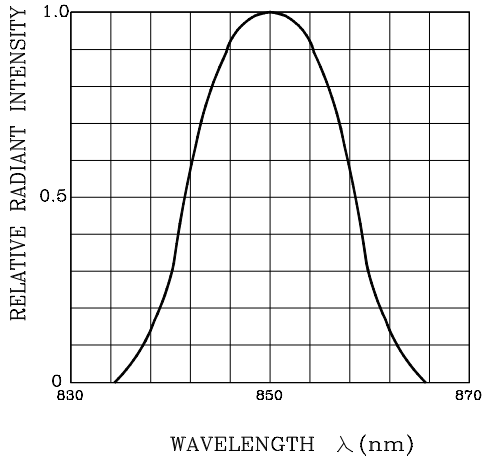

Fig.2 FORWARD CURRENT VS. AMBIENT TEMPERATURE

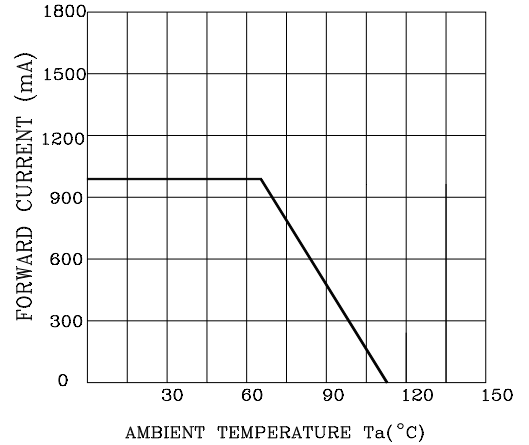

Fig.3 FORWARD CURRENT VS. FORWARD VOLTAGE

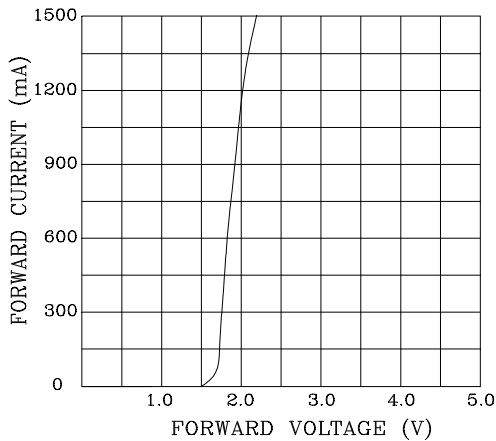

Fig.4 RELATIVE LUMINOUS INTENSITY VS. AMBIENT TEMPERATURE

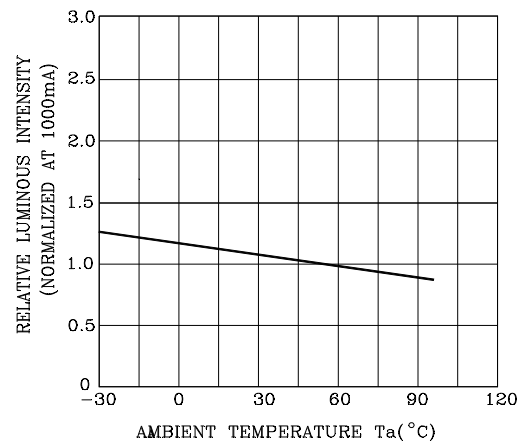

Fig.5 RELATIVE RADIANT POWER VS. FORWARD CURRENT

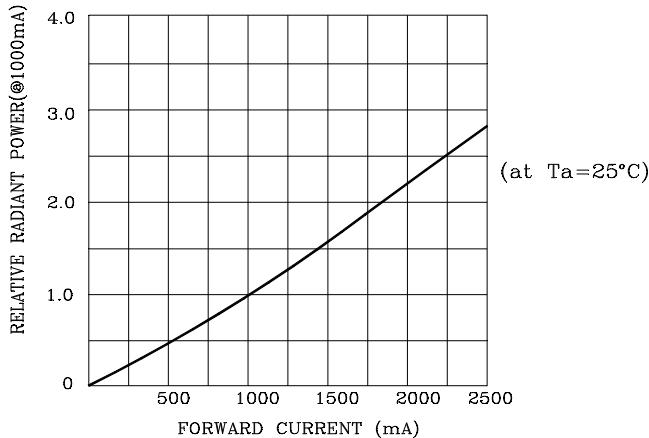
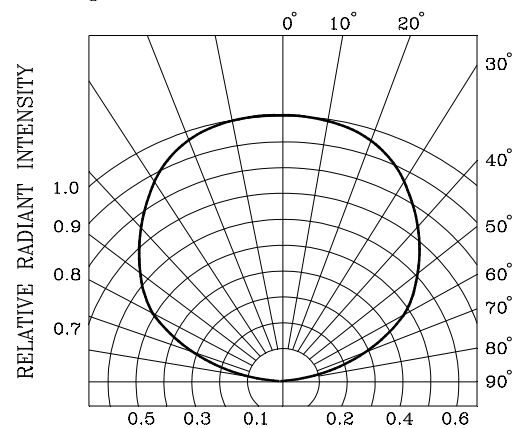

Fig.6 RADIATION DIAGRAM



### ● Bin Limits

#### 1. Power Bin Limits (At 1000 mA)

BIN CODE	Min. ( mW )	Max. ( mW )
X	585	760
Y	760	988

● Bin : X

↑  
Power bin code

NOTES: 1. Tolerance of measurement of Radiant Power.

### ● Soldering :

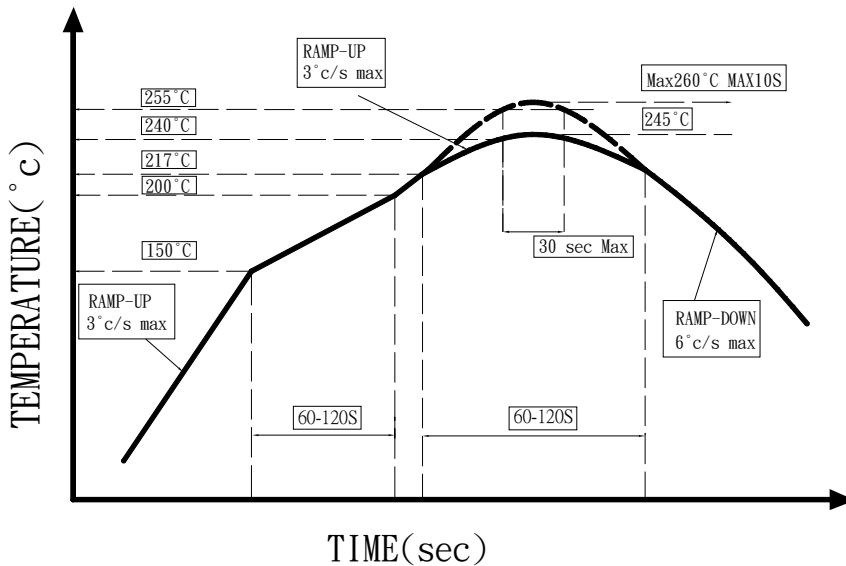

1. Avoid any external stress applied to the resin while the LEDs are at high temperature, especially during soldering .
2. Avoid rapid cooling or any excess vibration during temperature ramp-down process
3. Although the soldering condition is recommended above, soldering at the lowest possible temperature is feasible for the LEDs

### ● IRON Soldering

350°C Within 3 sec, one time only.

### ● Recommended Soldering Pattern (Unit:mm)

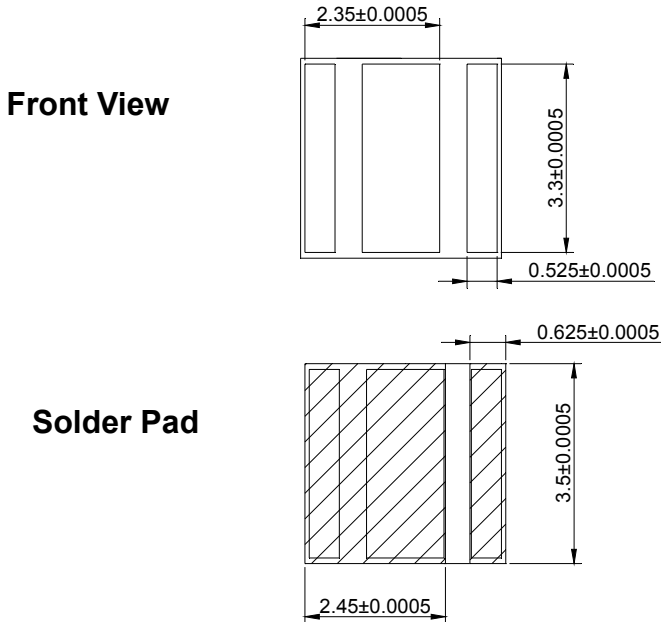

### ● Handling :

Care must be taken not to damage LED's silicone while exposing to high temperature or contact LED's silicone with hard or sharp objects, such as metal hook, tweezer or sand blasting.

### ● Notes for designing:

Current limiting resistor or a constant current power supply must be used in the circuit to drive BRIGHT LEDs within the rated figures and not to overload BRIGHT LEDs with instantaneous voltage at the turning ON and OFF cycles.

When using pulse driving, the average current must be within the rated figures. And the circuit should be designed to avoid reverse voltage when turning off the BRIGHT LEDs.

### ● Storage:

In order to avoid the absorption of moisture, it is recommended to solder BRIGHT LEDs as soon as possible after unpacking the sealed envelope.

If the envelope is still packed, to store it in the environment as following:

- (1) Temperature : 5°C-30°C (41°F) Humidity : RH 60% Max.
- (2) After this bag is opened, devices that will be applied to infrared reflow, vapor-phase reflow, or equivalent soldering process must be:
  - a. Completed within 24 hours.
  - b. Stored at less than 30% RH.
- (3) Devices require baking before mounting, if:
  - (2) a or (2) b is not met.
- (4) If baking is required, devices must be baked under below conditions:
  - 48 hours at 60°C±3°C.

### ● Package and Label of Products:

- (1) Package: Products are packed in one bag of 800 pcs (one taping reel) and a label is attached to each bag.
- (2) Label:

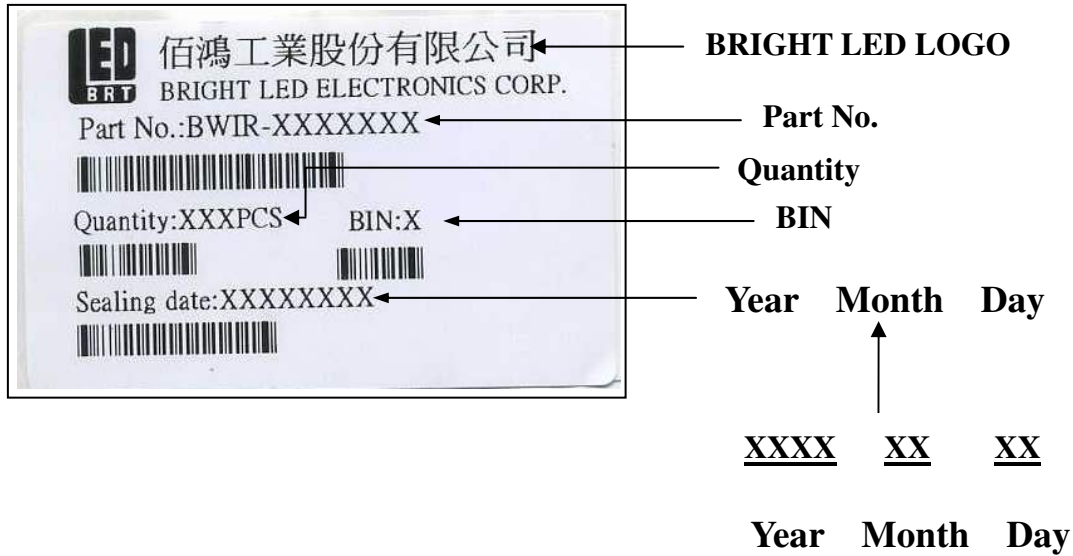

### ● Tapping and packaging specifications (Units: mm)

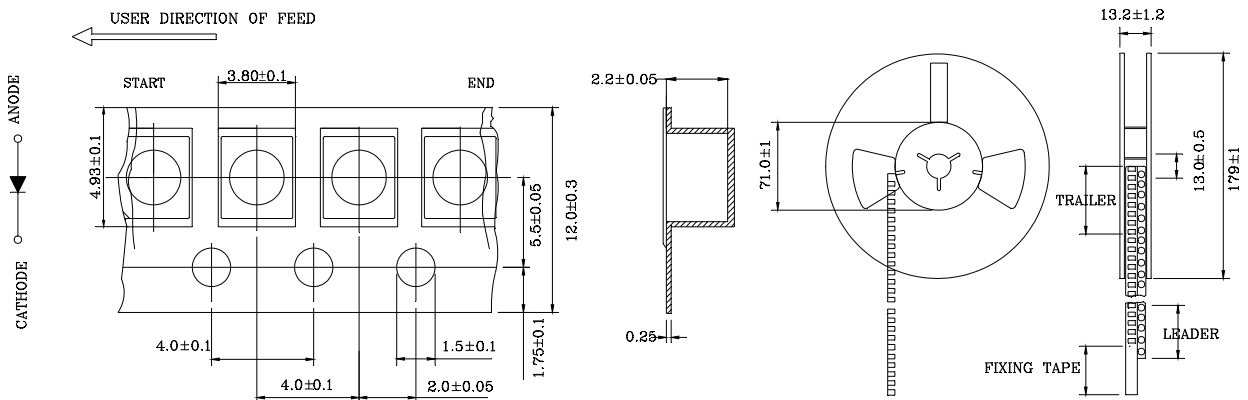

NOTE:2000 PCS PER REEL

● Package Method (unit:mm)

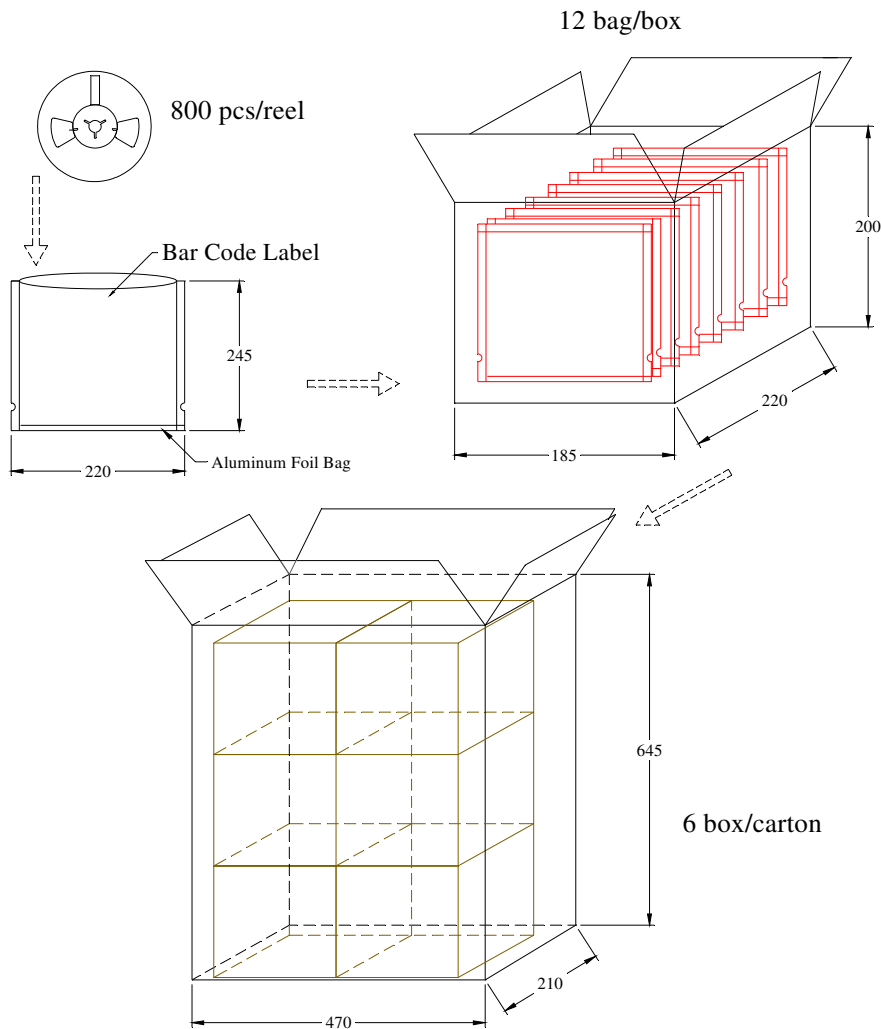

NOTES : Bag : Tolerance is  $\pm 5$  mm unless otherwise noted.  
Carton : Tolerance is  $\pm 10$  mm unless otherwise noted.