

**Order Number  
200218-4800**

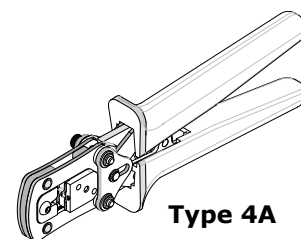

**Application Tooling Specification**



**FEATURES**

- A full-cycle ratcheting hand tool ensures complete crimps
- Ergonomically designed soft handles
- Precisely designed crimping profiles with simple contact positioning
- Easy handling due to outstanding force ratio
- This tool is IPC/WHMA-A-620 compliant
- Modular Crimp Head is removable and can be used in the Electric Crimp Machine (Order No. 63816-1900), accompanied by Crimp Adapter (Order No. 63816-1950)
- Can also be used in the Battery Powered Tool Order No. 63816-0270 (110 V) or 63816-0280 (220 V), accompanied by Crimp Adapter (Order No. 63816-1950)

**SCOPE**

**Products:** Board-In Crimp Terminals, 18 AWG UL1007 and 20 AWG UL1015 Wires.

Terminal Series No.	Terminal Order No.	Wire		(2) Insulation Diameter Maximum (3)		Strip Length	
	(1) Reel Form Only	Size	Type	mm	In.	mm	In.
4706-3	02-07-2101	18 AWG	UL1007	2.25	.089	5.9-6.4	.23-.25
	50-29-1688	20 AWG	UL1015	2.74	.108		

(1) Customer to cut terminal from reel. See "Preparing Terminals for Crimping" (page 2)  
 (2) To achieve IPC/WHMA A-620 crimps, see "Crimp Specification" (page 2)  
 (3) Terminal is designed for 3.05mm (.12 in) max insulation diameter; this crimp tool only accepts the maximum listed in the Scope table.

**DEFINITION OF TERMS**

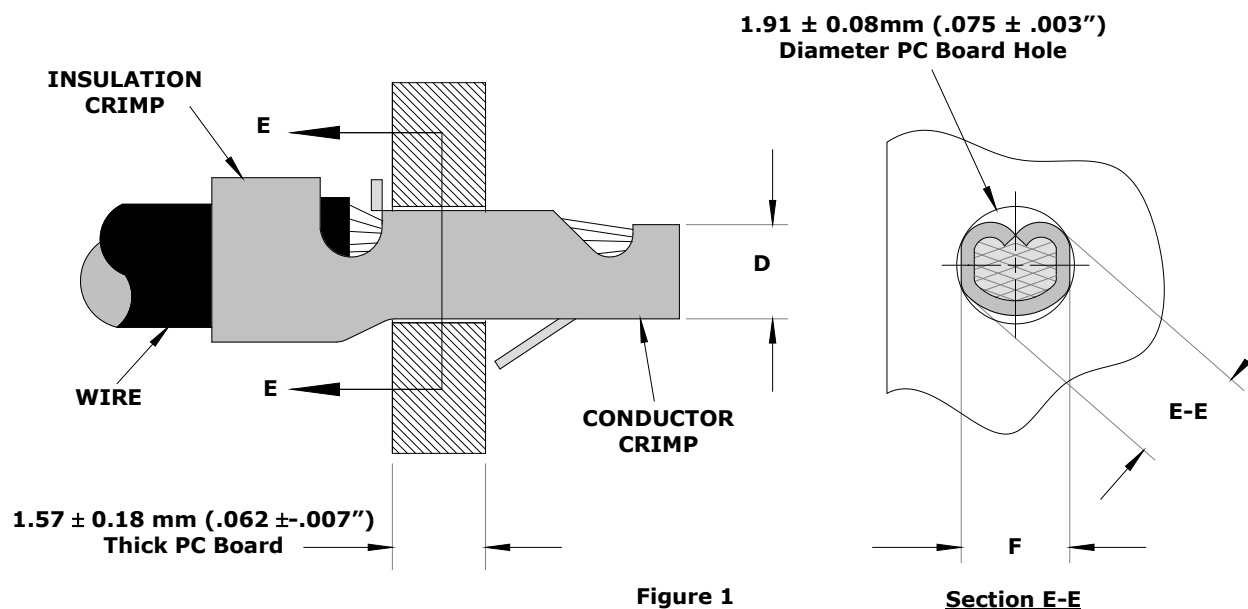

**CRIMP SPECIFICATION**

After crimping, the conductor profiles should measure the following (See Figure 1):

Terminal Series No.	Wire Size		Dimensions (Figure 1)						♦ Pull Force Minimum	
			D		E-E		F (Ref.)			
	AWG	mm <sup>2</sup>	mm	In.	mm	In.	mm	In.	N	Lb.
4706-3	18	—	1.070-1.170	.0420-.0460	1.720-1.780	.0677-.0700	1.38	.054	13.3	3
	20	—	0.870-0.970	.0342-.0382						

- ♦ The crimp on this terminal is not an electrical crimp; the final soldering operation is the electrical connection. This minimum pull force is what should be expected when pulling the terminal with both insulation and conductor crimped.

Crimp attribute specifications are as follows:

Terminal Series No.	Wire Size		Insulation Crimp				Brush		Cut-Off Dimension (Max)		Profile	
			Height (Ref.)		Width (Ref.)							
	AWG	mm <sup>2</sup>	mm	In.	mm	In.	mm	In.	mm	In.	18	20
4706-3	18	—	2.43	.096	2.30	.091	0.00-1.00	.000-.040	0.50	.020	X	
	20	—	2.65	.104	2.80	.110						X

To achieve IPC/WHMA-A-620 crimps, the following overall wire insulation diameter ranges are recommended:  
**Profile 18:** 1.82-2.25mm (.071-.089") or UL1007      **Profile 20:** 2.18-2.74mm (.085-.108") or UL1015

**Notes**

1. This tool should only be used for the terminals and wire gauges specified on this sheet.
2. This tool is not adjustable for crimp height. Variations in tools, terminals, wire stranding, and insulation types may affect crimp height.
3. This tool is intended for AWG conductors with UL1007 and UL1015 insulation. It may not give a good insulation crimp support for other insulation styles.
4. Molex does not repair hand tools (see Warranty on page 3). The replacement parts listed are the only parts available for repair. If the handles or crimp tooling are damaged or worn, a new tool must be purchased.
5. Pull force should be used as the final criterion for an acceptable crimp. Refer to Molex Quality Crimping Handbook 63800-0029 for additional information on crimping and crimp testing.
6. Molex does not certify crimp hand tools.

**OPERATION**

Open the tool by squeezing the handles together. At the end of the closing stroke, the ratchet mechanism will release the handles, and the hand tool will spring open.

**PREPARING TERMINALS FOR CRIMPING**

The terminals must be cut from the reel as shown. See Figure 2. The carrier strip hole is used to assist in loading the terminal in position over the crimp anvils. The carrier strip will help maintain terminal position during crimping and can be broken off after the crimp is complete.

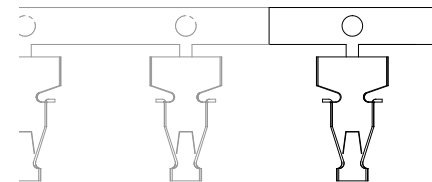
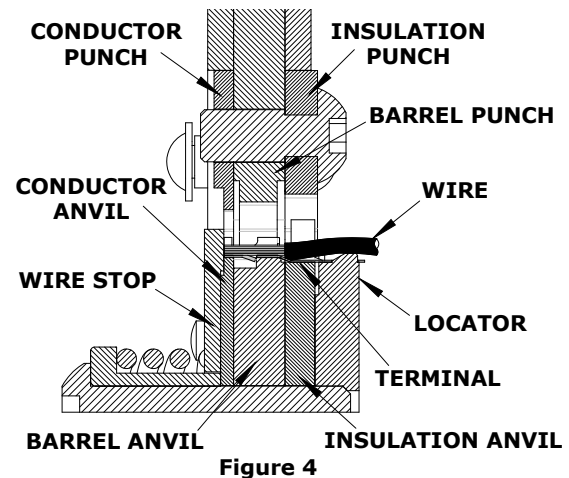
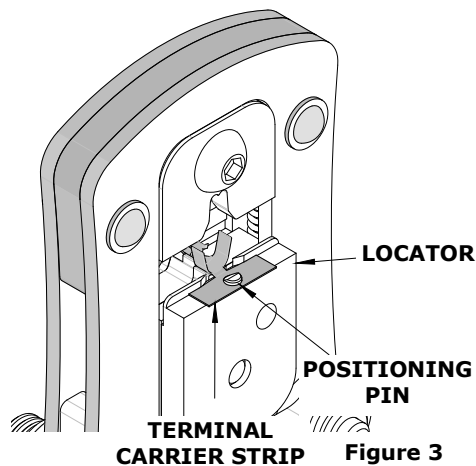

Figure 2

## CRIMPING TERMINALS

1. Load the terminal with carrier strip into the proper crimp profile. Make sure the carrier strip pilot hole fits over the positioning pin.
2. Place the properly stripped wire into the open terminal barrel. Push the wire into the tool until the end of the wire contacts the wire stop, making sure that all wire strands are inside of the conductor barrel. See Figures 3 and 4.
3. While holding the wire with one hand, slowly squeeze the tool handles together to close the tool jaws until the ratchet mechanism releases. At this point, the handles can be released and will spring open.
4. Remove the crimped terminal and inspect for acceptable crimp attributes.



**Note:** The tamper-proof ratchet action will not release the tool until it has been fully closed.

## MAINTENANCE

It is recommended that each operator of the tool be made aware of and responsible for the following maintenance steps:

1. Remove dust, moisture and other contaminants with a clean brush or a soft, lint-free cloth.
2. Do not use any abrasive materials that could damage the tool.
3. Make certain all pins, pivot points and bearing surfaces are protected with a thin coat of high-quality machine oil. Do not oil excessively. The tool was engineered for durability, but like any other equipment, it needs cleaning and lubrication for a maximum service life of trouble-free crimping. Light oil (such as 30 weight automotive oil) used at the oil points every 5,000 crimps or 3 months will significantly enhance the tool life.
4. Wipe excess oil from the hand tool, particularly from the crimping area. Oil transferred from the crimping area onto certain terminations may affect the electrical characteristics of an application.
5. When tool is not in use, keep the handles closed to prevent objects from becoming lodged in the crimping dies, and store the tool in a clean, dry area.

## Warranty

This tool is for electrical terminal crimping purposes only. This tool is made of the best quality materials. All vital components are long-life tested. All tools are warranted to be free of manufacturing defects for a period of 30 days. Should such a defect occur, Molex will repair or exchange the tool free of charge. This repair or exchange will not be applicable to altered, misused or damaged tools. This tool is designed for hand use only. Any clamping, fixturing or use of handle extensions voids this warranty.

**CAUTION:** Repetitive use of this tool should be avoided.

**CAUTIONS**

1. Manually powered hand tools are intended for low-volume use or field repair. This tool is **NOT** intended for production use. Repetitive use of this tool should be avoided.
2. Insulated rubber handles are not protection against electrical shock.
3. Wear eye protection at all times.
4. Use only the Molex terminals specified for crimping with this tool.

**CAUTION:** Molex crimp specifications are valid only when used with Molex terminals and tooling.

**APPLICATIONS FOR THE MODULAR CRIMP HEAD**

**WARNING:** NEVER operate, service, install or adjust this modular crimp head without proper instruction and without first reading and understanding the instructions in the proper manual or specification sheet. See chart below for the correct manual or specification sheet.

**WARNING:** NEVER install tooling or service this tool while it is connected to any power source. Disconnect the power by unplugging or turn off the actuator from its power source.

**CAUTION:** Keep fingers away from the crimping area when operating this tool. It may cause severe injury.

**CAUTION:** Wear safety glasses when operating or servicing this tool.

The chart below shows all applications for this modular crimp head:

Tool Order No.	Tool Description	Adapter Order No.	Adapter Description	Figure No.
63816-0270	Battery Power Tool (110 V)	63816-1950	Crimp Adapter	3
63816-0280	Battery Power Tool (220 V)	63816-1950	Crimp Adapter	3
63816-1900	Electric Crimp Machine	63816-1950	Crimp Adapter	4

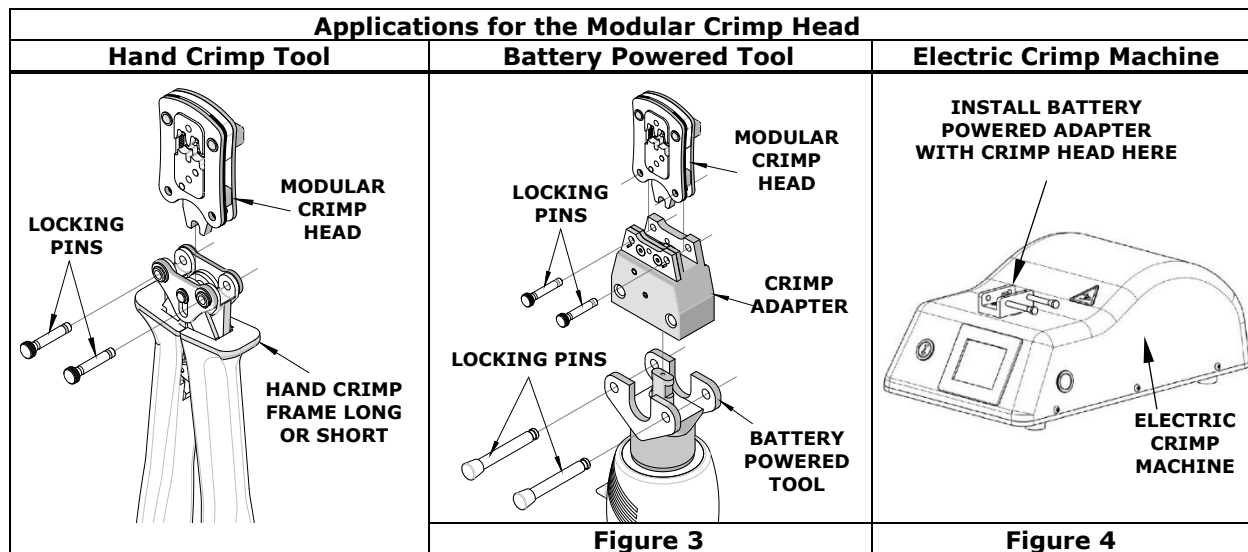

**PARTS LIST**

Item	Order Number	Description	Quantity
1	---	Hand Crimp Frame	1
2	200218-4875	Locator Plate	1
3	63816-0001	Locking Pin	2
4	63600-0525	Handle Spring	1
5	63600-0520	Crimping Spring	2

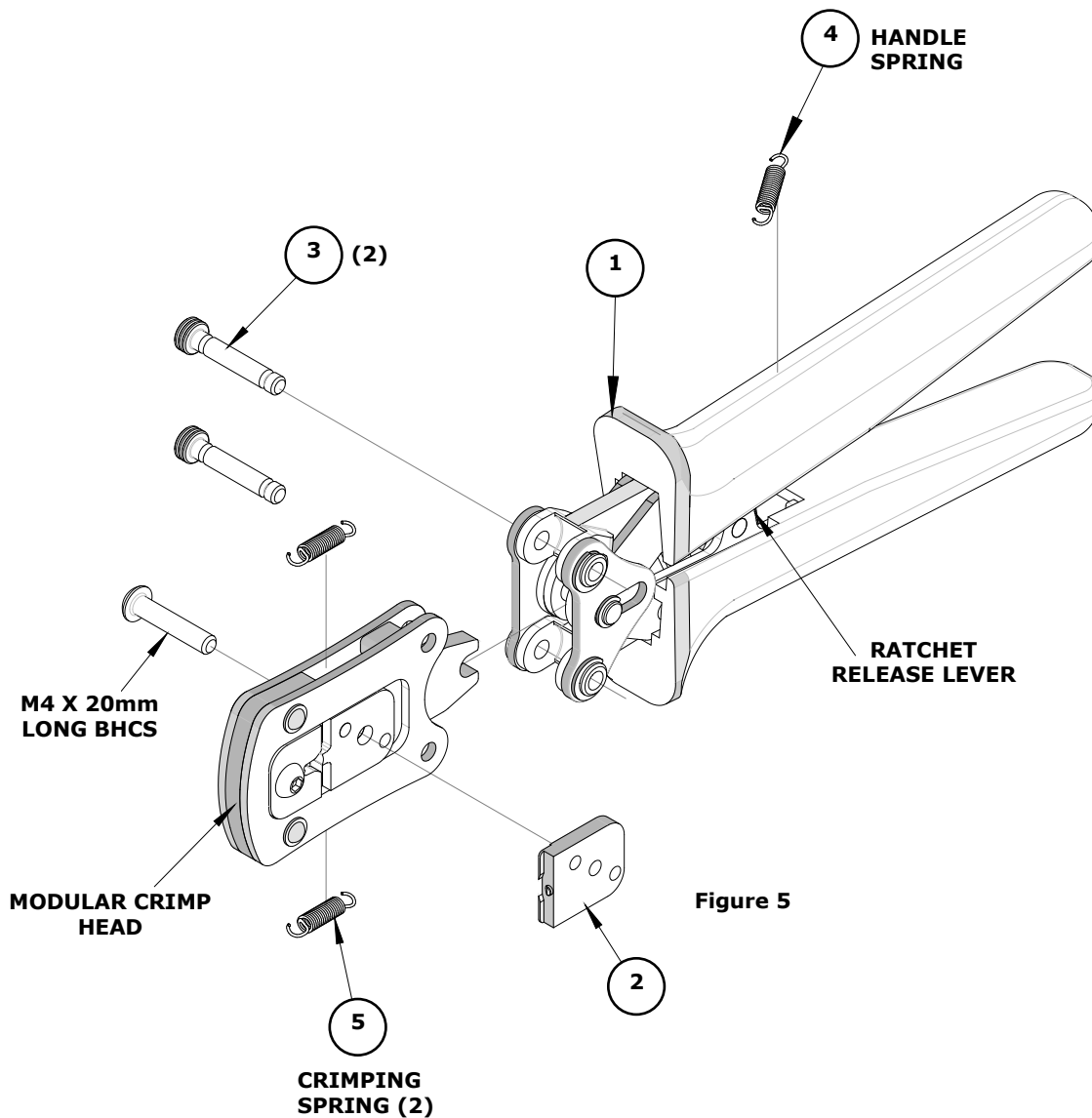

**Application Tooling Support**

**E-Mail:** [toolingsupport@molex.com](mailto:toolingsupport@molex.com)  
**Website:** [www.molex.com/applicationtooling](http://www.molex.com/applicationtooling)

Molex is a registered trademark of Molex, LLC in the United States of America and may be registered in other countries; all other trademarks listed herein belong to their respective owners.