

LOC		DIST		REV		REV		REVISIONS	
GP	00	P	F	ZONE	LTR	DESCRIPTION	DATE	APPD	
					AT	REVISED PER EC 0513-0121-03	11DEC03	JG	

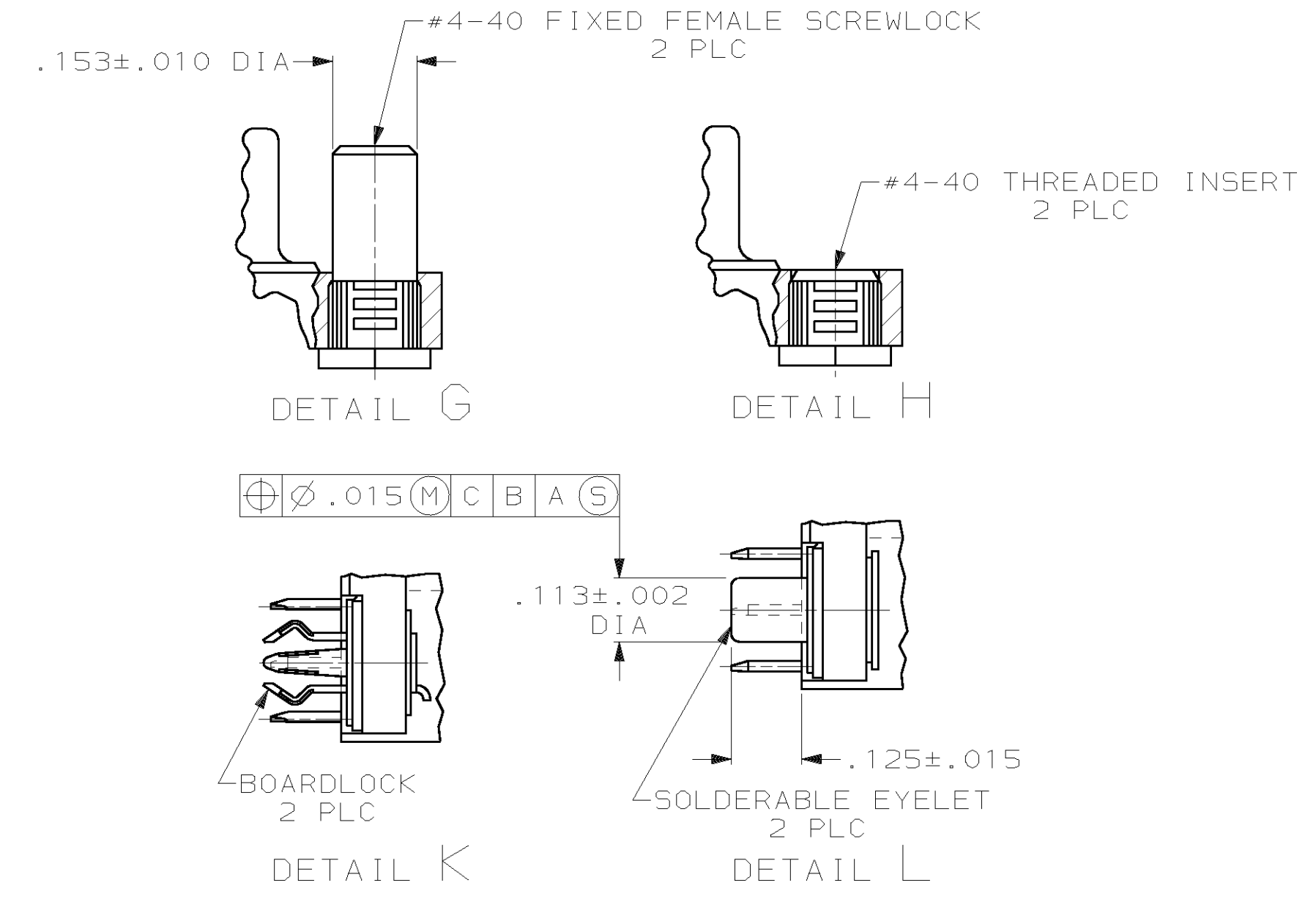

- 1. POSITION TOLERANCE APPLIES AT TIP ONLY.
- 2. NYLON, 94 V-0 RATED, BLACK.
- 3. PHOS. BRONZE PER QQ-B-750.
- 4. STEEL PER ASTM A109.
- 5. FLAT EYELETS & SOLDERABLE EYELETS: BRASS; BOARDLOCKS: COPPER ALLOY; INSERTS & SCREWLOCKS: ZINC.
- 6. GOLD PLATING PER MIL-G-45204, NICKEL PLATING PER QQ-N-290, TIN PLATING PER MIL-T-10727.
- 7. BRIGHT TIN PLATED.
- 8. FLAT EYELETS: BRIGHT TIN PLATED; SOLDERABLE EYELETS & BOARDLOCKS: TIN-LEAD PLATED; SCREWLOCKS: CLEAR CHROMATE; INSERTS: CLEAR CHROMATE.
- 9. POSITION TOLERANCE APPLIES TO .125 DIA HOLE OR TO DIAMETER ESTABLISHED BY LEGS OF BOARDLOCK.
- 10. PLATED WITH GOLD (SEE TABLE FOR THICKNESS) ON MATING END, .000120 MIN TIN-LEAD ON SOLDER END, ALL OVER .000050 MIN NICKEL.
- 11. PART NO INCLUDES BULK PACKED SCREWLOCKS.
- 12. POSITION NUMBERS SHOWN FOR REFERENCE ONLY.
- 13. THIS CONNECTOR IS RATED TO A TEMPERATURE OF 220° C MAX AND 90 SECOND MAXIMUM EXPOSURE TIME.

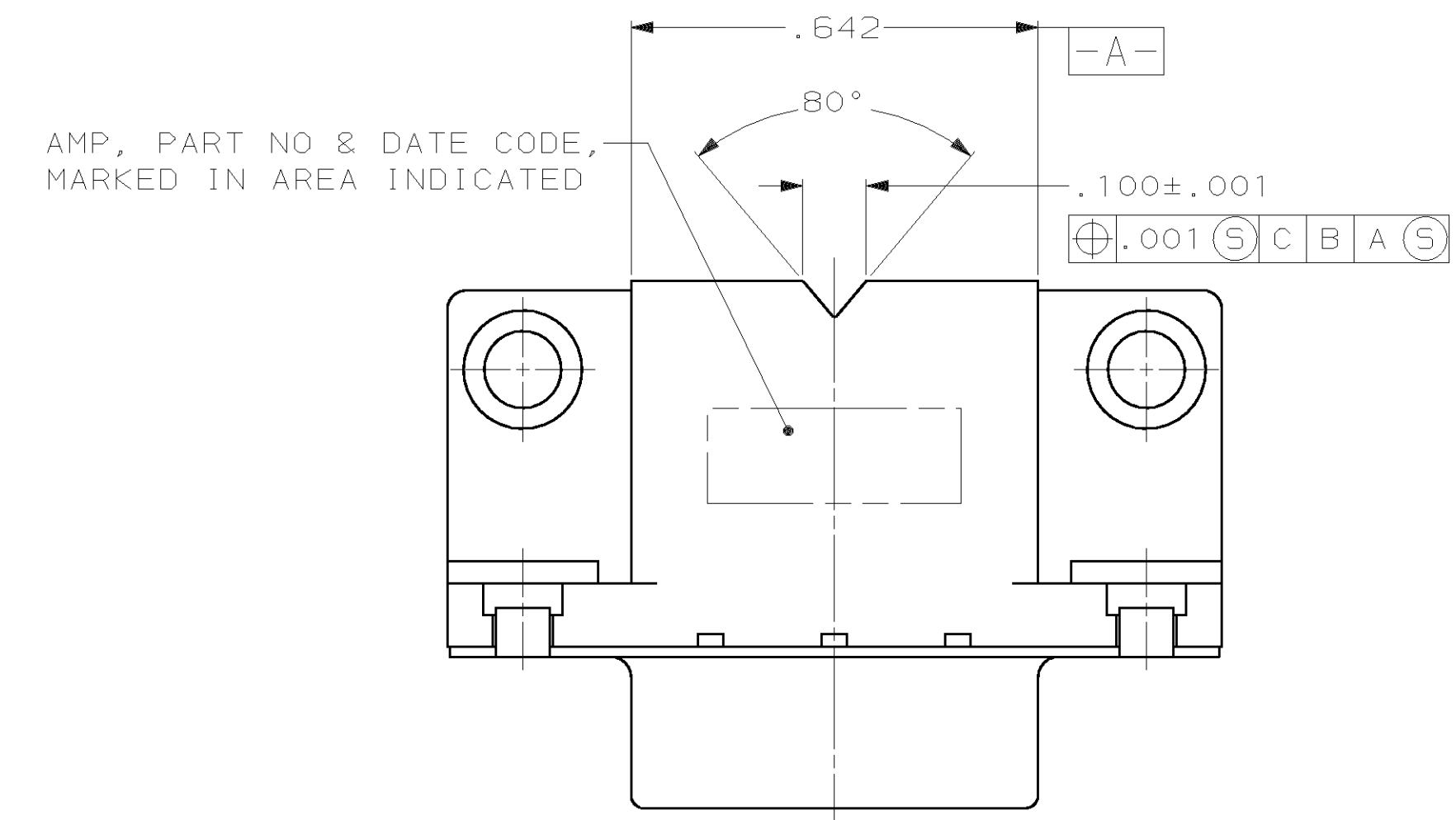
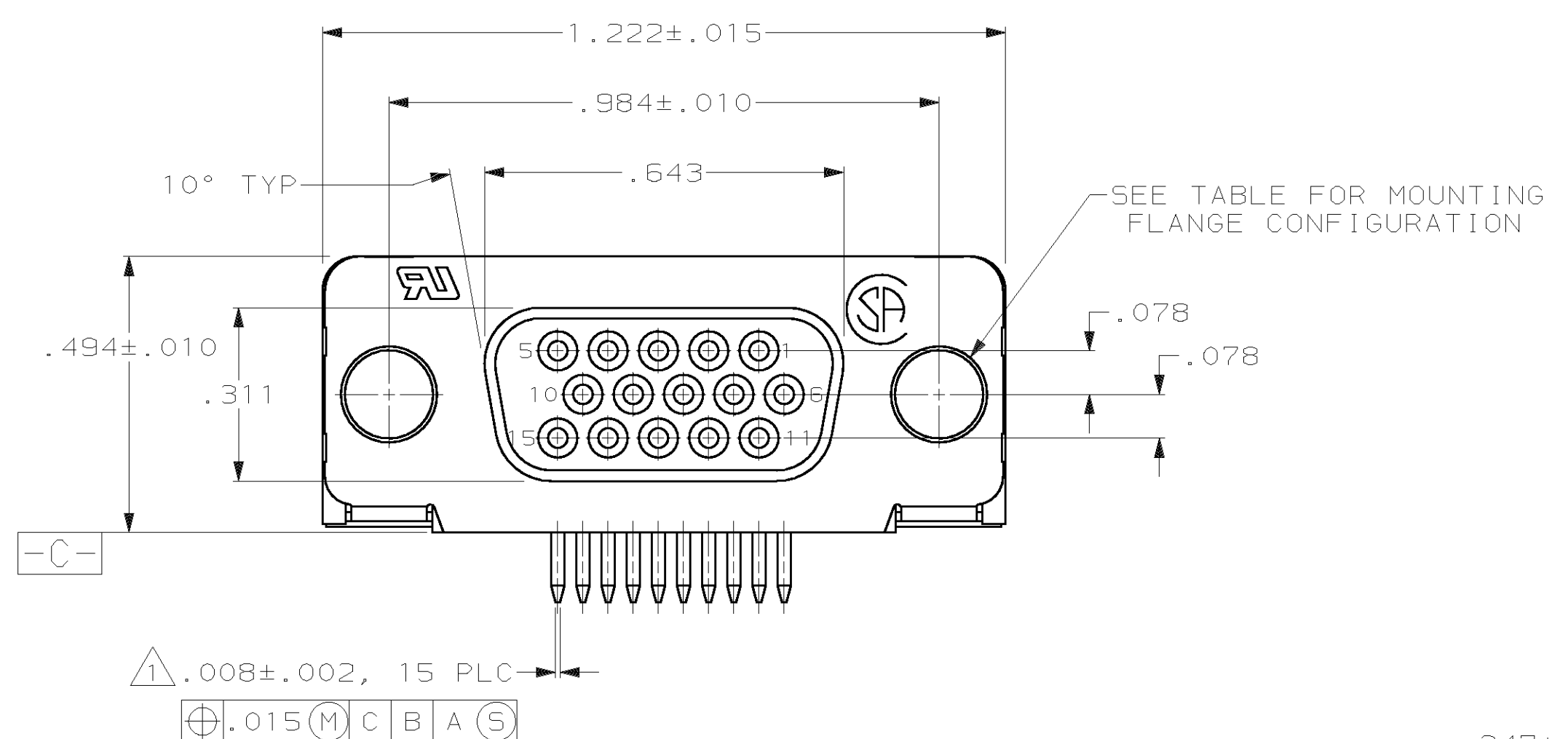

REVISION	DESCRIPTION	DATE	APPD
1	OBsolete		
2	SUPERSEDED BY 1470250-6		
3	SUPERSEDED BY 1-1470250-4		
4	SUPERSEDED BY 2-1470250-3		
5	SUPERSEDED BY 1-1470250-6		
6	SUPERSEDED BY 1-748390-1		
7	SUPERSEDED BY 1-748390-1		
8	SUPERSEDED BY 1-748390-1		
9	SUPERSEDED BY 1-748390-1		
10	SUPERSEDED BY 1-748390-1		
11	SUPERSEDED BY 1-748390-1		
12	SUPERSEDED BY 1-748390-1		
13	SUPERSEDED BY 1-748390-1		
14	SUPERSEDED BY 1-748390-1		
15	SUPERSEDED BY 1-748390-1		
16	SUPERSEDED BY 1-748390-1		
17	SUPERSEDED BY 1-748390-1		
18	SUPERSEDED BY 1-748390-1		
19	SUPERSEDED BY 1-748390-1		
20	SUPERSEDED BY 1-748390-1		
21	SUPERSEDED BY 1-748390-1		
22	SUPERSEDED BY 1-748390-1		
23	SUPERSEDED BY 1-748390-1		
24	SUPERSEDED BY 1-748390-1		
25	SUPERSEDED BY 1-748390-1		
26	SUPERSEDED BY 1-748390-1		
27	SUPERSEDED BY 1-748390-1		
28	SUPERSEDED BY 1-748390-1		
29	SUPERSEDED BY 1-748390-1		
30	SUPERSEDED BY 1-748390-1		
31	SUPERSEDED BY 1-748390-1		
32	SUPERSEDED BY 1-748390-1		
33	SUPERSEDED BY 1-748390-1		
34	SUPERSEDED BY 1-748390-1		
35	SUPERSEDED BY 1-748390-1		
36	SUPERSEDED BY 1-748390-1		
37	SUPERSEDED BY 1-748390-1		
38	SUPERSEDED BY 1-748390-1		
39	SUPERSEDED BY 1-748390-1		
40	SUPERSEDED BY 1-748390-1		
41	SUPERSEDED BY 1-748390-1		
42	SUPERSEDED BY 1-748390-1		
43	SUPERSEDED BY 1-748390-1		
44	SUPERSEDED BY 1-748390-1		
45	SUPERSEDED BY 1-748390-1		
46	SUPERSEDED BY 1-748390-1		
47	SUPERSEDED BY 1-748390-1		
48	SUPERSEDED BY 1-748390-1		
49	SUPERSEDED BY 1-748390-1		
50	SUPERSEDED BY 1-748390-1		
51	SUPERSEDED BY 1-748390-1		
52	SUPERSEDED BY 1-748390-1		
53	SUPERSEDED BY 1-748390-1		
54	SUPERSEDED BY 1-748390-1		
55	SUPERSEDED BY 1-748390-1		
56	SUPERSEDED BY 1-748390-1		
57	SUPERSEDED BY 1-748390-1		
58	SUPERSEDED BY 1-748390-1		
59	SUPERSEDED BY 1-748390-1		
60	SUPERSEDED BY 1-748390-1		
61	SUPERSEDED BY 1-748390-1		
62	SUPERSEDED BY 1-748390-1		
63	SUPERSEDED BY 1-748390-1		
64	SUPERSEDED BY 1-748390-1		
65	SUPERSEDED BY 1-748390-1		
66	SUPERSEDED BY 1-748390-1		
67	SUPERSEDED BY 1-748390-1		
68	SUPERSEDED BY 1-748390-1		
69	SUPERSEDED BY 1-748390-1		
70	SUPERSEDED BY 1-748390-1		
71	SUPERSEDED BY 1-748390-1		
72	SUPERSEDED BY 1-748390-1		
73	SUPERSEDED BY 1-748390-1		
74	SUPERSEDED BY 1-748390-1		
75	SUPERSEDED BY 1-748390-1		
76	SUPERSEDED BY 1-748390-1		
77	SUPERSEDED BY 1-748390-1		
78	SUPERSEDED BY 1-748390-1		
79	SUPERSEDED BY 1-748390-1		
80	SUPERSEDED BY 1-748390-1		
81	SUPERSEDED BY 1-748390-1		
82	SUPERSEDED BY 1-748390-1		
83	SUPERSEDED BY 1-748390-1		
84	SUPERSEDED BY 1-748390-1		
85	SUPERSEDED BY 1-748390-1		
86	SUPERSEDED BY 1-748390-1		
87	SUPERSEDED BY 1-748390-1		
88	SUPERSEDED BY 1-748390-1		
89	SUPERSEDED BY 1-748390-1		
90	SUPERSEDED BY 1-748390-1		
91	SUPERSEDED BY 1-748390-1		
92	SUPERSEDED BY 1-748390-1		
93	SUPERSEDED BY 1-748390-1		
94	SUPERSEDED BY 1-748390-1		
95	SUPERSEDED BY 1-748390-1		
96	SUPERSEDED BY 1-748390-1		
97	SUPERSEDED BY 1-748390-1		
98	SUPERSEDED BY 1-748390-1		
99	SUPERSEDED BY 1-748390-1		
100	SUPERSEDED BY 1-748390-1		

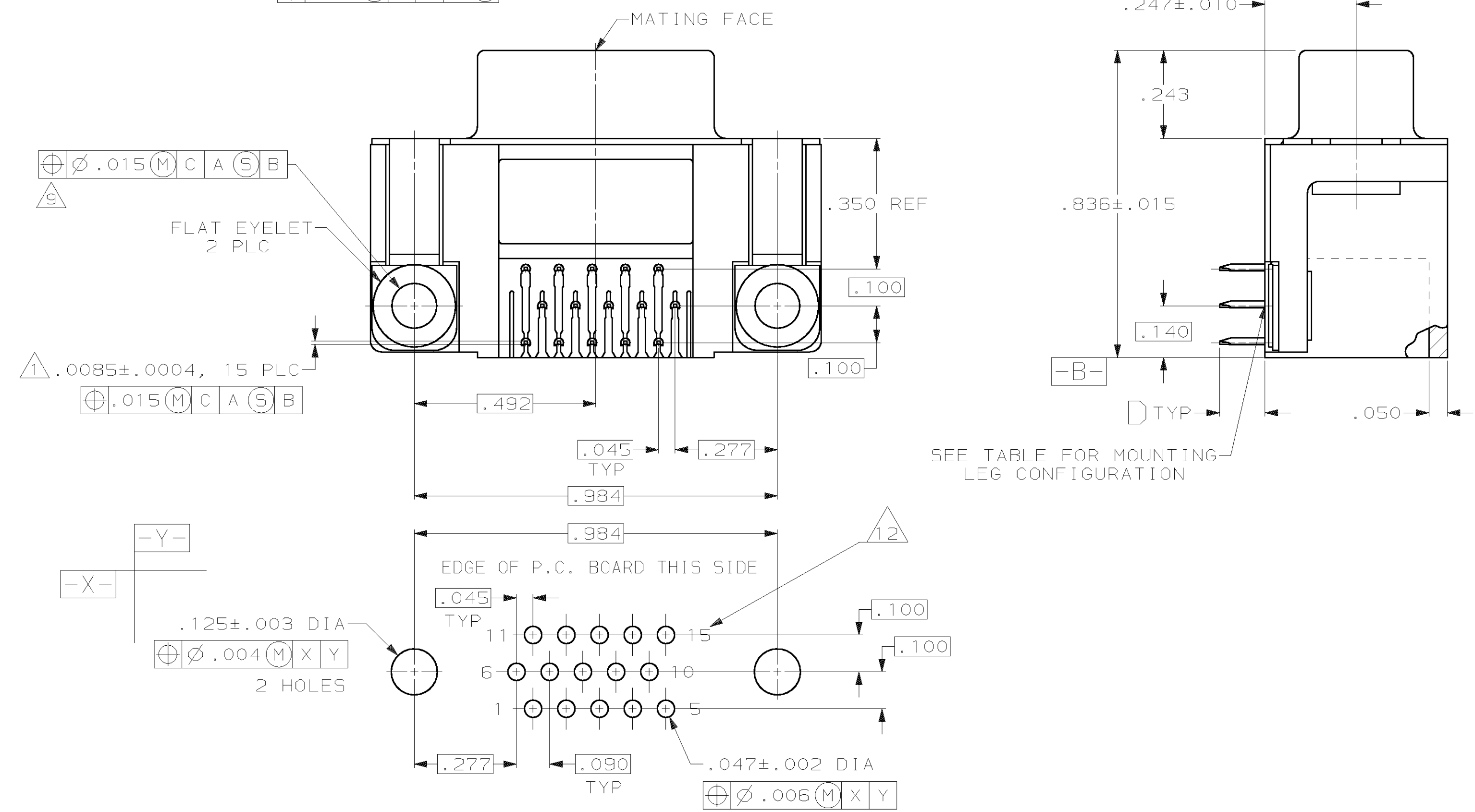

P.C. BOARD MOUNTING DIMENSIONS  
 (.062 PC BOARD THICKNESS FOR SOLDERABLE EYELETS & BOARDLOCKS)  
 (.093 MAX PC BOARD THICKNESS WITHOUT SOLDERABLE EYELETS & BOARDLOCKS)

DO NOT SCALE PRINT. UNLESS SPECIFIED DIMENSIONS IN INCHES TOLERANCES ON: 2 PLC DEC ± .005 3 PLC DEC ± .005 ANGLES ± 2°	DR 1-27-88 C.RICHARD CHK 1-29-88 S.WELDON APPD 1-29-88 P.KISSINGER APPD 2-1-88 C.RHODE	AMP INCORPORATED Harrisburg, Pa. 17105
MATERIAL: NYLON MOLDED PARTS: NYLON CONTACTS: PHOS. BRONZE SHELL: STEEL HARDWARE: STEEL	FINISH: BRIGHT TIN CONTACTS: TIN-LEAD SHELL: GOLD HARDWARE: CLEAR CHROMATE	NAME: RECEPTACLE ASSY, SIZE 1, 15 POSN, RIGHT ANGLE, FRONT METAL SHELL, AMPLIMITE®HD-22
PRODUCT SPEC: 108-1092	APPLICATION SPEC: 114-40021	SIZE: D
WEIGHT: -	SCALE: 4:1	FSCM NO: 00779
		DRAWING NO: 748390
		SHEET: 1 OF 1