



TLE 84110EL

DECA Half-bridge Driver for DC-Motor

THE TLE 84110EL IS A PROTECTED Deca-Half-Bridge-Driver designed especially for DC Motor Control in automotive applications such as flap motors in HVAC systems (Heating Ventilation Air Conditioning).

The 10 half-bridge drivers are designed to drive DC motor loads in sequential or parallel operation. Operation modes forward (cw), reverse (ccw), brake and high impedance are controlled from a 16-bit SPI interface.

The extremely small 24 pin fine pitch exposed pad package in a SO-14 body provides good thermal performance and reduces PCB-board space and costs.

Applications

- Flap DC motor driver for heating, ventilation and air conditioning systems (HVAC)

Key Features

- 10-halfbridges to drive up to 5 motors in parallel mode or 9 motors in sequential mode
- Minimum Overcurrent Threshold of 1A
- Simple communication and error diagnosis via 16-bit SPI
- Lowest quiescent current product on the market
- Pin, package and SW compatible to TLE 84106EL
- AEC qualified

Key Benefits

- Easy implementation of motor drives
- Over current, Over temperature, Over voltage and Open Load Diagnosis
- Family compatibility provides flexibility to drive 3 to 5 motors in parallel mode or 5 to 9 motors in cascaded configuration
- Automotive applications

TLE 84110EL

DECA Half-bridge Driver for DC-Motor

Block Diagram

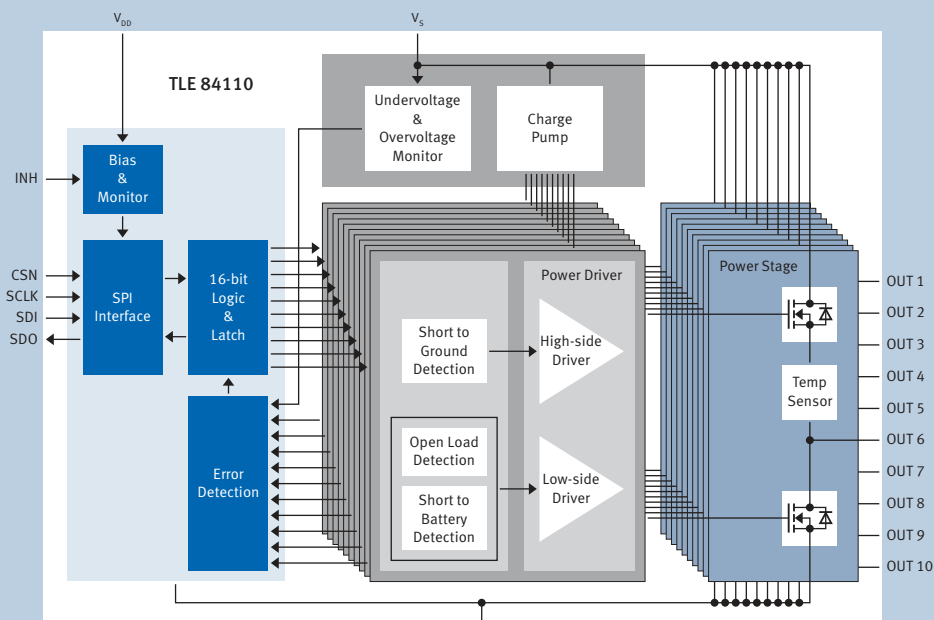

Application Diagram

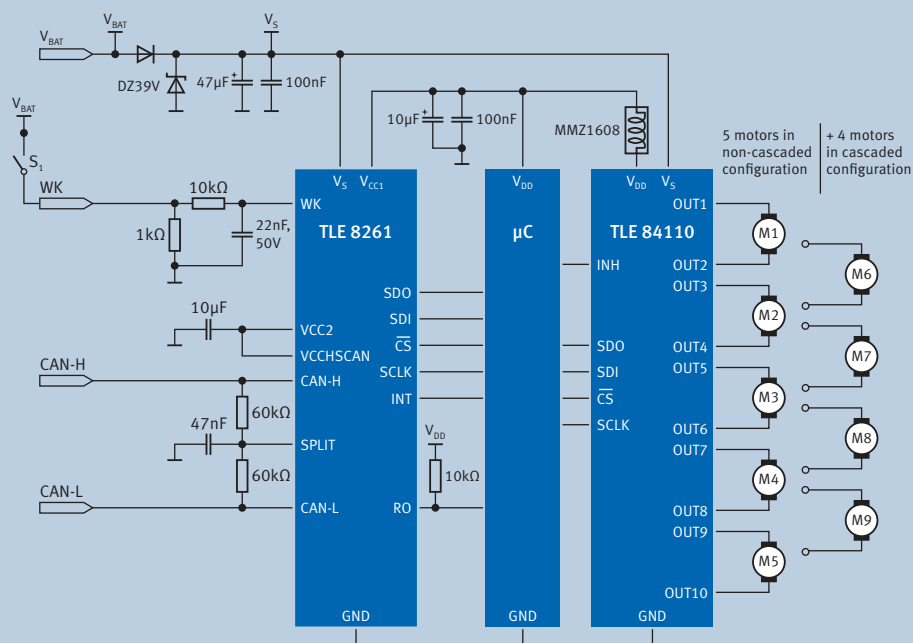

How to reach us:
<http://www.infineon.com>

Published by
 Infineon Technologies AG
 81726 Munich, Germany

© 2010 Infineon Technologies AG
 All Rights Reserved.

Legal Disclaimer The information given in this Product Brief shall in no event be regarded as a guarantee of conditions or characteristics. With respect to any examples or hints given herein, any typical values stated herein and/or any information regarding the application of the device, Infineon Technologies hereby disclaims any and all warranties and liabilities of any kind, including without limitation, warranties of non-infringement of intellectual property rights of any third party.

Information For further information on technology, delivery terms and conditions and prices, please contact the nearest Infineon Technologies Office (www.infineon.com).

Warnings Due to technical requirements, components may contain dangerous substances. For information on the types in question, please contact the nearest Infineon Technologies Office. Infineon Technologies components may be used in life-support devices or systems only with the express written approval of Infineon Technologies, if a failure of such components can reasonably be expected to cause the failure of that life-support device or system or to affect the safety or effectiveness of that device or system. Life support devices or systems are intended to be implanted in the human body or to support and/or maintain and sustain and/or protect human life. If they fail, it is reasonable to assume that the health of the user or other persons may be endangered.