

NPH Series

Solid State Medium Pressure Sensors



Applications

- Process control, P-to-I converters
- Pneumatic control systems
- HVAC controls
- Biomedical: Infusion pumps, sphygmomanometers, respirators
- Aerospace: Altimeters, barometers, cabin pressure sensors
- Computer peripherals

Features

- Solid state, high reliability
- Standard TO-8 package suitable for PC board mount
- Low cost, small size
- Available in gauge, absolute, and differential pressure versions
- Media compatible with non-corrosive gases and dry air
- Typical FSO 100 mV @ 1.5 mA
- Thermal accuracy FSO 0.4% typical
- Overpressure capability to five times maximum rated pressure
- Three standard ranges: 15, 30 and 100 psi (1, 2 and 7 bar)
- Nonlinearity 0.05% FSO typical
- Standard 3/16 in OD pressure port
- Ceramic substrate with temperature compensation resistors

NPH Series Specifications

Description

An integrated circuit silicon sensor chip is housed in a standard TO-8 electrical package that is printed circuit board mountable.

The latest techniques in micromachining have been used to ion-implant piezoresistive strain gauges into a wheatstone bridge configuration that is integrally formed on a micromachined silicon diaphragm. As with all NovaSensor silicon sensors, the NPH Series employs SenStable® processing technology, providing excellent

output stability. Constant current excitation to the sensor produces a voltage output that is linearly proportional to the input pressure.

The user can provide standard signal conditioning circuitry to amplify the 100 mV output signal. The sensor is compatible with most non-corrosive gases and dry air.

A laser-trimmed, thick-film resistor network on a hybrid ceramic substrate provides temperature compensation.

Parameter	Value	Units	Notes
General			
Pressure Range	0 to 15	psi	(0 to 1 bar) 0 to 100 kPa
	0 to 30	psi	(0 to 2 bar) 0 to 200 kPa
	0 to 100	psi	(0 to 7 bar) 0 to 700 kPa
Maximum Pressure	4x		rated pressure ⁽⁸⁾
Electrical @ 77°F (25°C) Unless Otherwise Stated			
Input Excitation	1.5	mA	2 mA maximum
Insulation Resistance	10 ⁸	Ω	@ 50 VDC
Input Impedance	4000	Ω	±20%
Output Impedance	5000	Ω	±20%
Bridge Impedance	5000	Ω	±20%
Environmental			
Temperature Range			
Operating ⁽⁹⁾	-40 to 257	°F	(-40°C to 125°C)
Compensated	32 to 158	°F	(0°C to 70°C)
Vibration	10	gRMS	20 to 2000 Hz
Shock	100	g	11 milliseconds
Life (Dynamic Pressure Cycle)	1 x 10 ⁶	cycles	
Mechanical ⁽¹¹⁾			
Weight	<0.2	oz	(<5 g)
Media Compatibility	Non-corrosive gases and clean, dry air		
Wetted Materials			
Top Port	Nickel, gold plated Kovar, silicone gel, gold wire, RTV, silicon and glass.		
Bottom Port	Gold plated Kovar, silicon, glass and RTV (10)		

Parameter	Units	Min.	Type	Max.	Notes
Performance Parameters(7), Compensated(1), 100, 200 and 700 kPa					
Offset	mV	-2	1	2	
Full Scale Output	mV	75	100	125	2
Linearity	%FSO	-0.1	0.05	0.1	3
Hysteresis and Repeatability	%FSO	-0.05	0.01	0.05	
Thermal Accuracy of Offset					
100 kPa	%FSO	-0.6	0.4	0.6	4
200 and 700 kPa	%FSO	-0.5	0.2	0.5	4
Thermal Accuracy of FSO					
100 kPa	%FSO	-0.6	0.4	0.6	4
200 & 700 kPa	%FSO	-0.5	0.2	0.5	4
Thermal Hysteresis	%FSO	-0.1	0.05	0.1	5
Short-Term Stability of Offset	μV/V		5		6, 11
Short-Term Stability of FSO	μV/V		5		6, 11

1. Performance with offset , thermal accuracy of offset , and thermal accuracy of FSO compensation resistors.
2. FSO with 1.5 mA input excitation.
3. Best fit straight line.
4. 32°F to 158°F (0°C to 70°C) with reference to 77°F (25°C)
5. 32°F to 158°F (0°C to 70°C), by design.
6. Normalized offset/bridge voltage—100 hrs, typical value, not tested in production.
7. All values at 77°F (25°C) and at 1.5 mA, unless otherwise noted.
8. Topside pressure. Backside pressure maximum pressure is 250 psi (17.23 bar) or 4x rated pressure, whichever is less.
9. Reduced performance outside compensation range.
10. Backside differential tube is nickel or Kovar.
11. Typical specifications are for reference only; absolute values may vary.

NPH Series Specifications

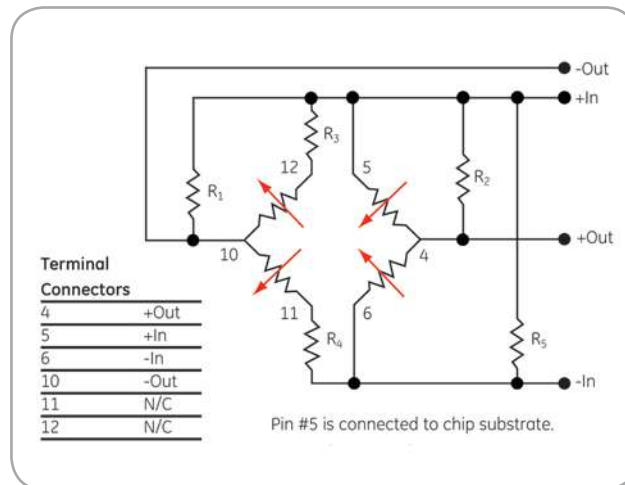

NPH Series schematic diagram

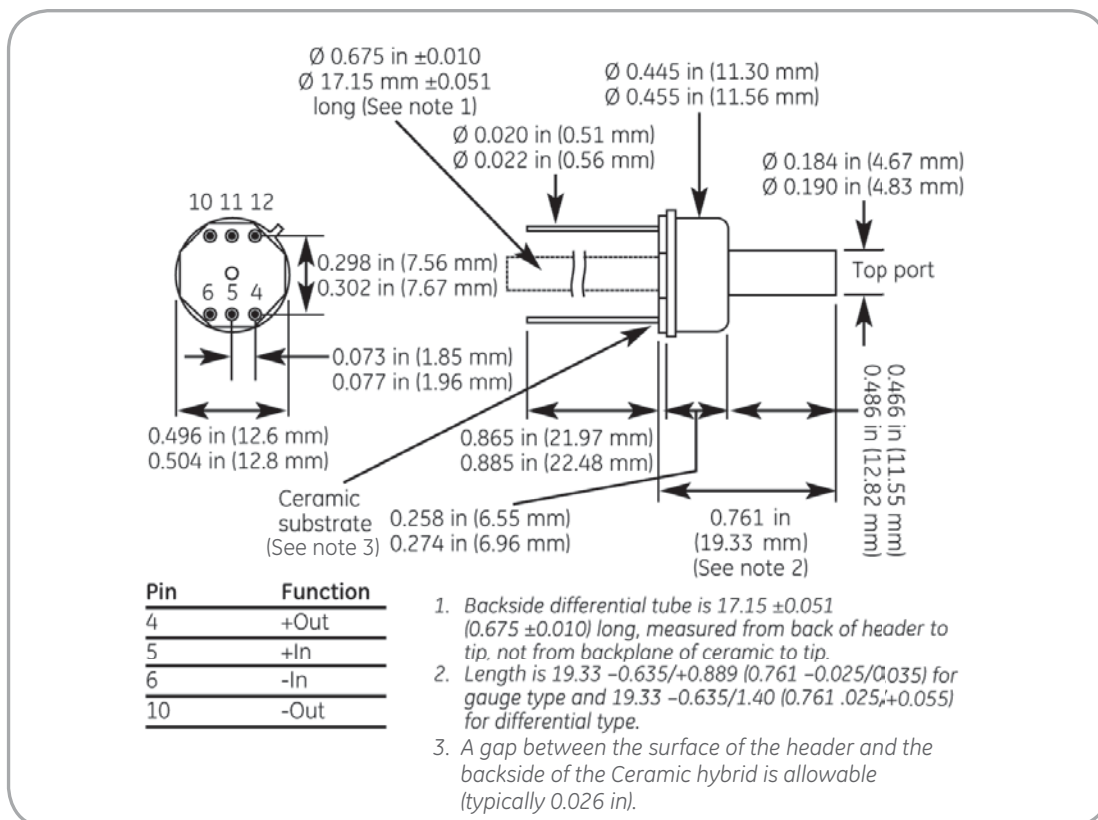

NPH Series package diagram

