

LOC		DIST		REVISIONS			
F	LTR	DESCRIPTION	DATE	DNW	APVD		
A		INITIAL RELEASE	18NOV2010	RC	CW		

- 1 MATERIAL:
CONTACT: PHOSPHOR BRONZE.
HOUSING: GLASS-FILLED POLYESTER.
- 2 GENERAL PLATING SPECIFICATION: UNDERPLATING
(ENTIRE CONTACT): 1.27μm MIN NICKEL AND ACTION
PIN: 0.5μm MIN TIN/LEAD.
1.27μm MIN GOLD PLATING ON MATING SURFACES
- 3 CONFORMS TO ALL TESTING ACCORDING TO IEC 61076-4-101
PERFORMANCE LEVEL 1.
- 4 CONNECTOR MARKED WITH PART NUMBER AND DATE CODE.
ADDITIONAL CHARACTERS OR MARKINGS, AS WELL AS THE LOCATION OF THE MARKINGS,
MAY BE ADDED FOR TRACEABILITY BASED UPON MANUFACTURERS DISCRETION.
- 5 PLATED-THROUGH HOLES AT 2x2mm SQUARE GRID
PATTERN DEFINED BY CONTACT LAYOUT.
- 6 10 PLATED THROUGH HOLES FOR UPPER SHIELD, ROW F.
- 7 SHIELD MOUNTED TO CONNECTOR WITH DOUBLE SIDED ADHESIVE TAPE OR ADHESIVE.

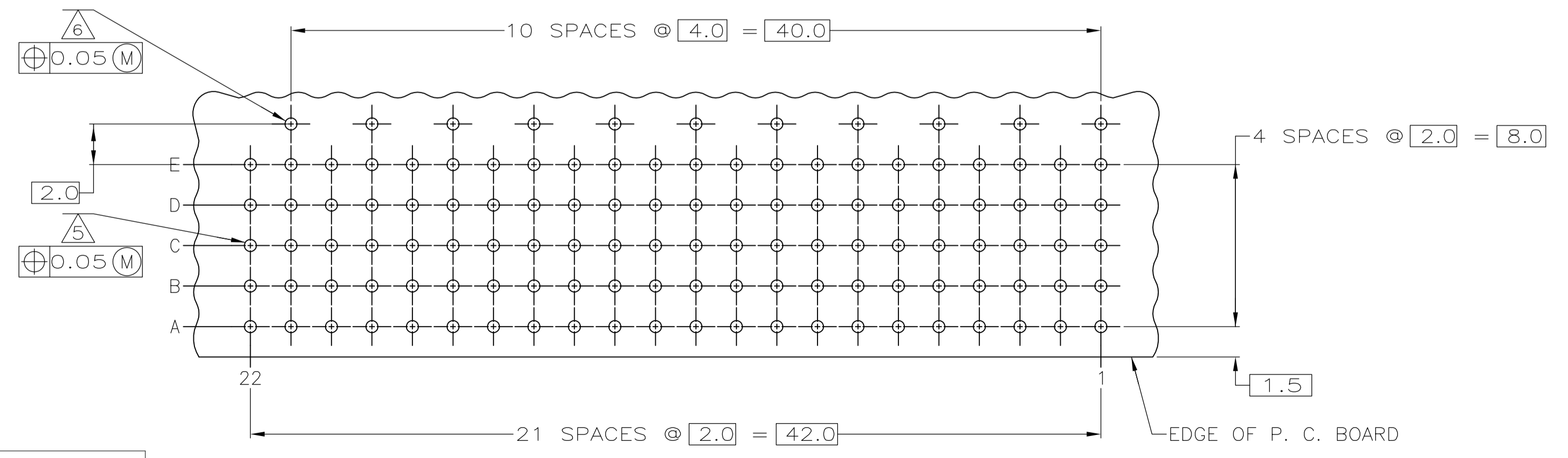
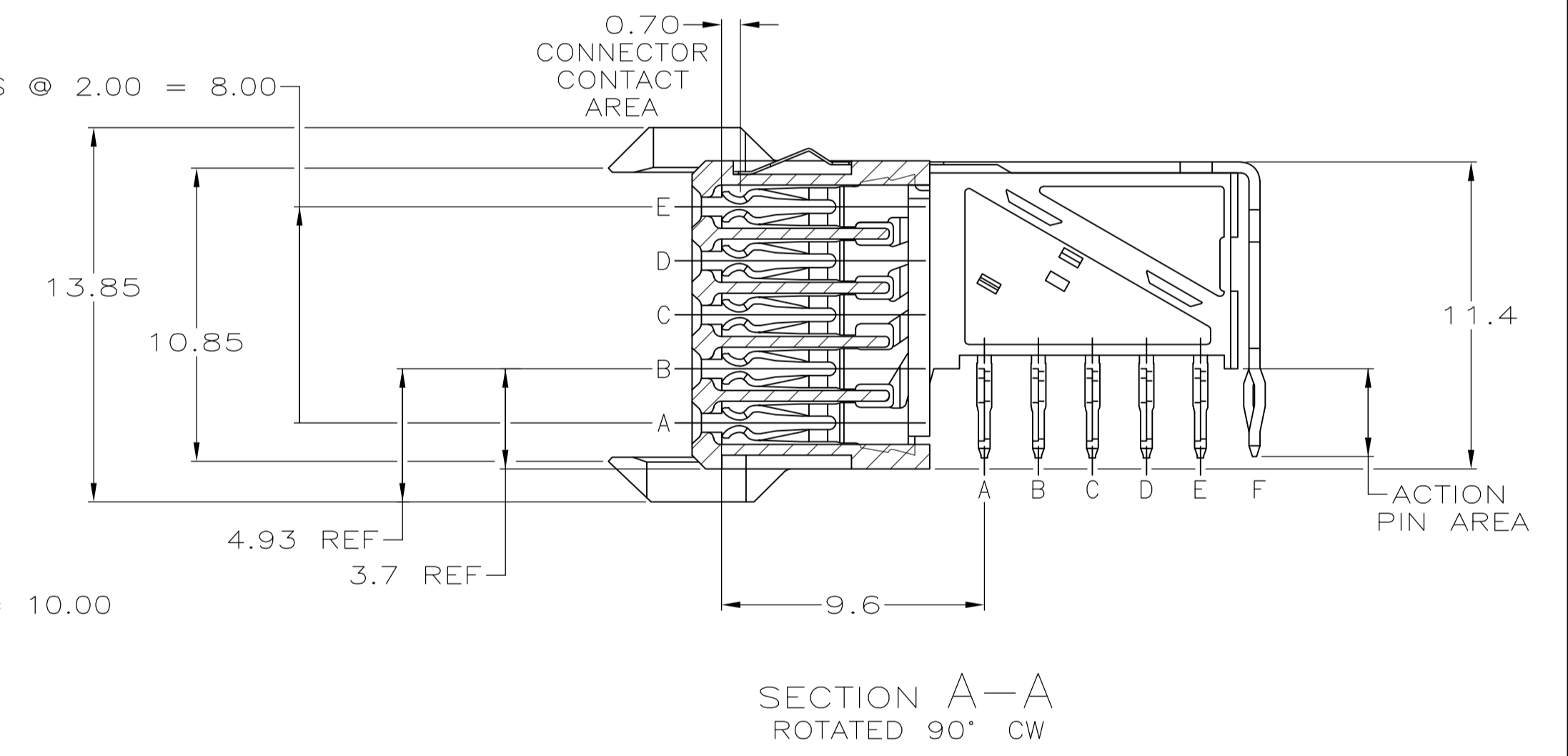
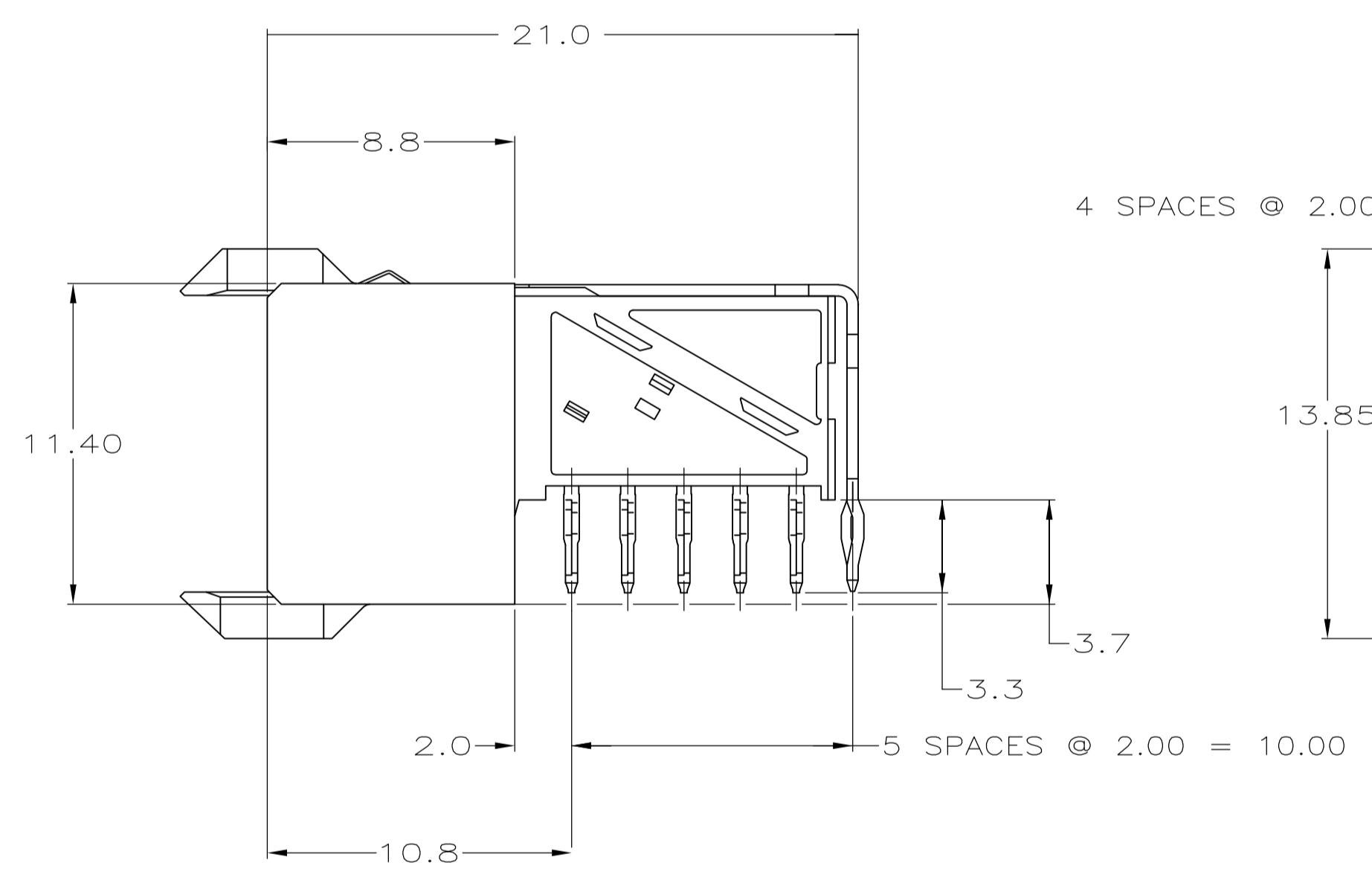
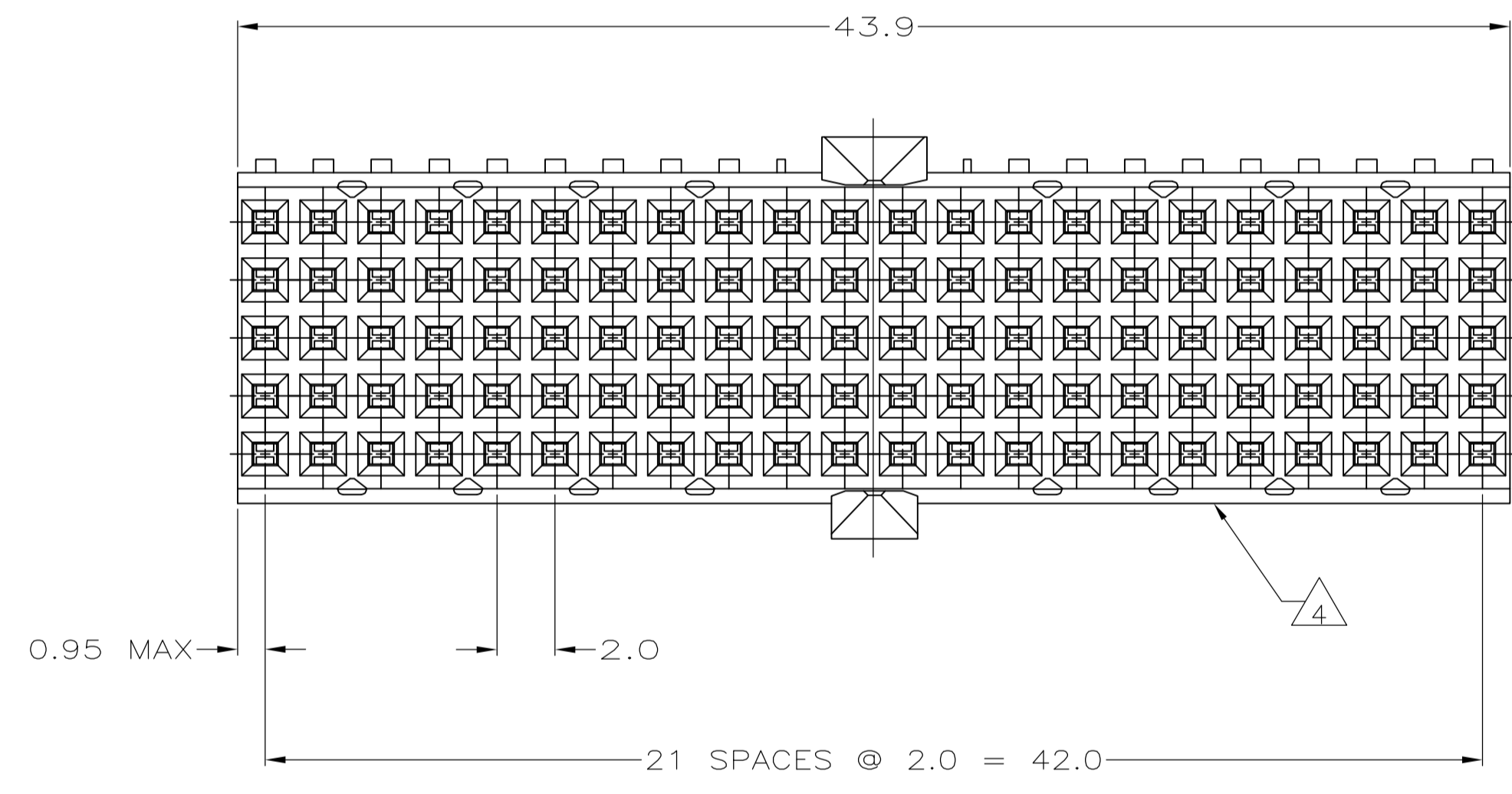
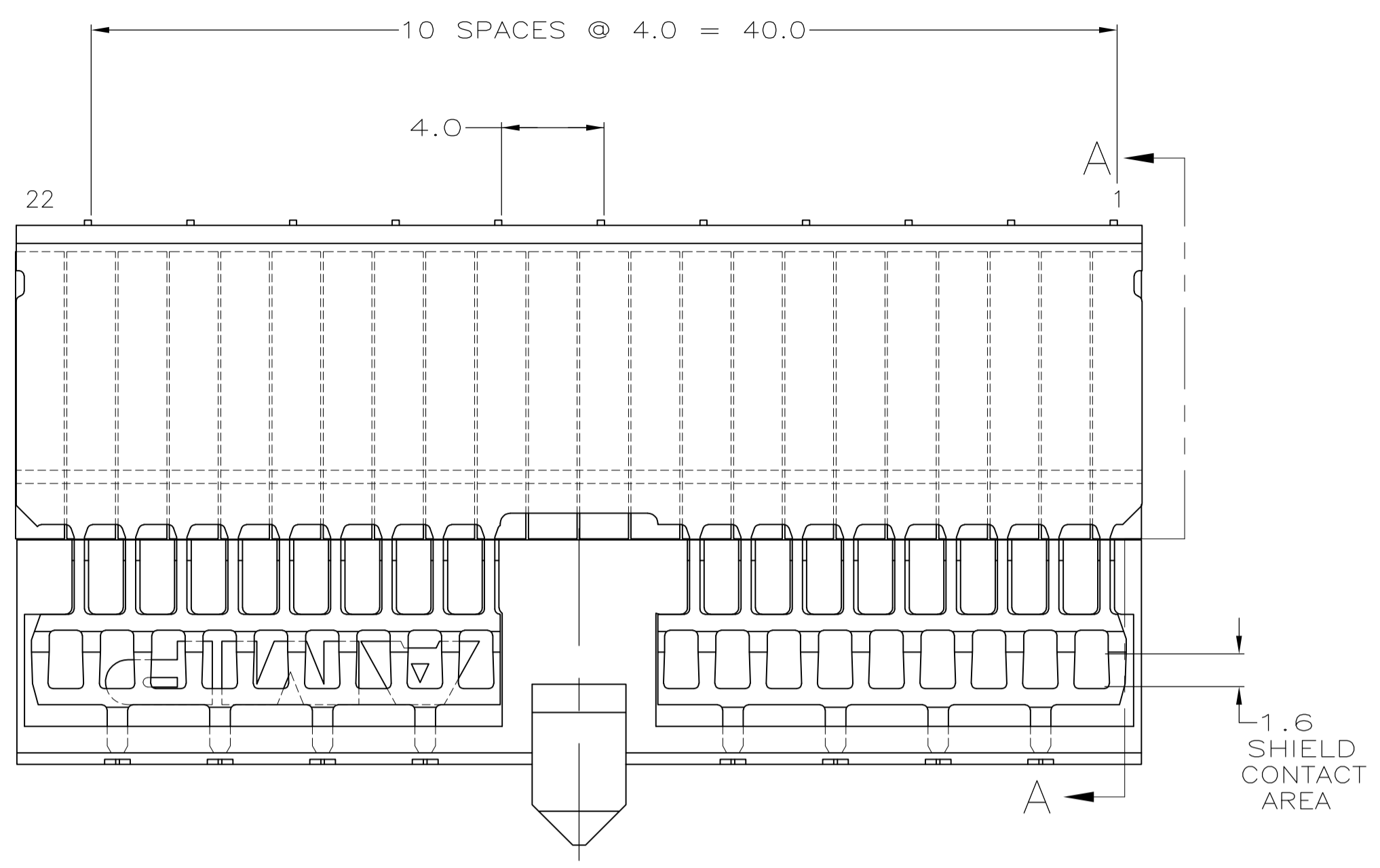

PLATED THRU HOLES PARAMETERS
 REFERENCE APPLICATION SPECIFICATION

RECOMMENDED PCB-HOLE LAYOUT
 COMPONENT SIDE SHOWN
 SCALE 2.5:1

THIS DRAWING IS A CONTROLLED DOCUMENT.		DIN RAYMOND CAO 11/18/2010		Tyco Electronics Corporation	
DIMENSIONS: mm		CHK SANDERS YAN 11/18/2010		Shanghai, P.R.China, 200233	
TOLERANCES UNLESS OTHERWISE SPECIFIED:		APVD MANQIAN WANG 11/18/2010		NAME RECEPTACLE ASSEMBLY, Z-PACK 2mm HM, TYPE A/B, PRE-SHIELDED, 110 POSITION	
0-PLC ±		PRODUCT SPEC 108-19082		SIZE CAGE CODE DRAWING NO	
1-PLC ± 0.2		APPLICATION SPEC 114-19029		RESTRICTED TO	
2-PLC ± 0.02		WEIGHT		A1 00779 1645594	
3-PLC ±		CUSTOMER DRAWING		SCALE 5:1 SHEET 1 OF 1 REV A	
4-PLC ±					
ANGLES ±					
FINISH SEE TABLE					