

1 2 3 4 5 6 7

A

B

C

D

E

F

G

H

A

B

C

D

E

F

G

H

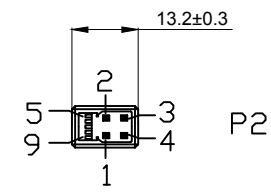
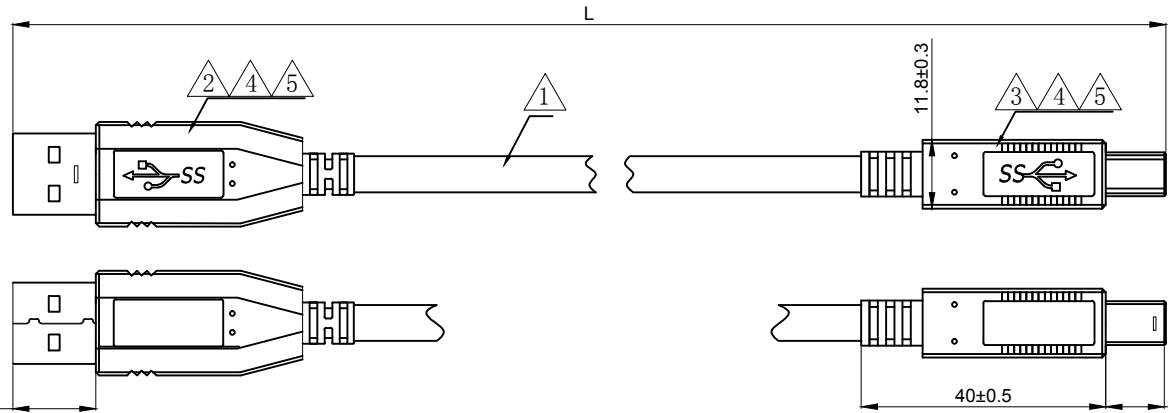
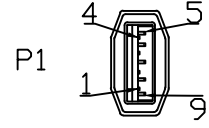

① Pin Assignment

P1		P2
1	Red	1
2	White	2
3	Green	3
4	Black	4
5	Blue	5
6	Yellow	6
7	Drain	7
8	Orange	8
9	Purple	9
Shell	Braid	Shell

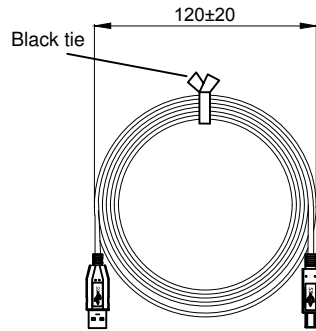

NOTES:

1. Cable Must Be Open, Short, Miswire 100% Test
2. Voltage: 300V DC
3. Contact Resistance: 5ohms max.
4. Insulation Resistance: 10M ohms min.

WSW P/N	Length(mm)	PE BAG SIZE
A-USB30AM-30BM-050	500±20	150*200*0.05mm
A-USB30AM-30BM-100	1000±30	150*230*0.05mm
A-USB30AM-30BM-200	2000±50	150*230*0.05mm
A-USB30AM-30BM-300	3000±50	170*280*0.05mm
A-USB30AM-30BM-500	5000±50	170*280*0.05mm

NO.	TITLE	DESCRIPTION
△	Inner Mold	LDPE WHITE
△	Over Mold	PVC 60P Black
△	CONN	USB3.0 B/M, Blue PBT, PIN G/F, Shell Ni-Plated
△	CONN	USB3.0 A/M, Blue PBT, PIN G/F, Shell Ni-Plated
△	CABLE	UL2725(Rev 3.0), OD:5.5mm BLACK, (1P#30+D+AL+Mylar)*2C+1P#30+2C#24+AL+B

RoHS compliant
Unit: mm

Scale	FREE					Date	Name	Customer-No.
TOLERANCE					Drawn	07.01.2019	Xavier	
					Approved	07.01.2019	Winnie	ASSMANN WSW-No. A-USB30AM-30BM-xxx
DIM	TOL	①	Add wire color	07.15.2019	Xavier			
		②	Drawn	07.01.2019	Xavier			
Angle	TOL	Id.	Modification	Date	Name	Drawing-No. ASS 8453 CA		rev01
						Replace		Sheet 1/1

1 2 3 4 5 6 7