

REVISIONS					
P	LTR	DESCRIPTION	DATE	DN	APVD
L2	REVISED PER	ECO-20-000170	21MAY2020	KR	JO

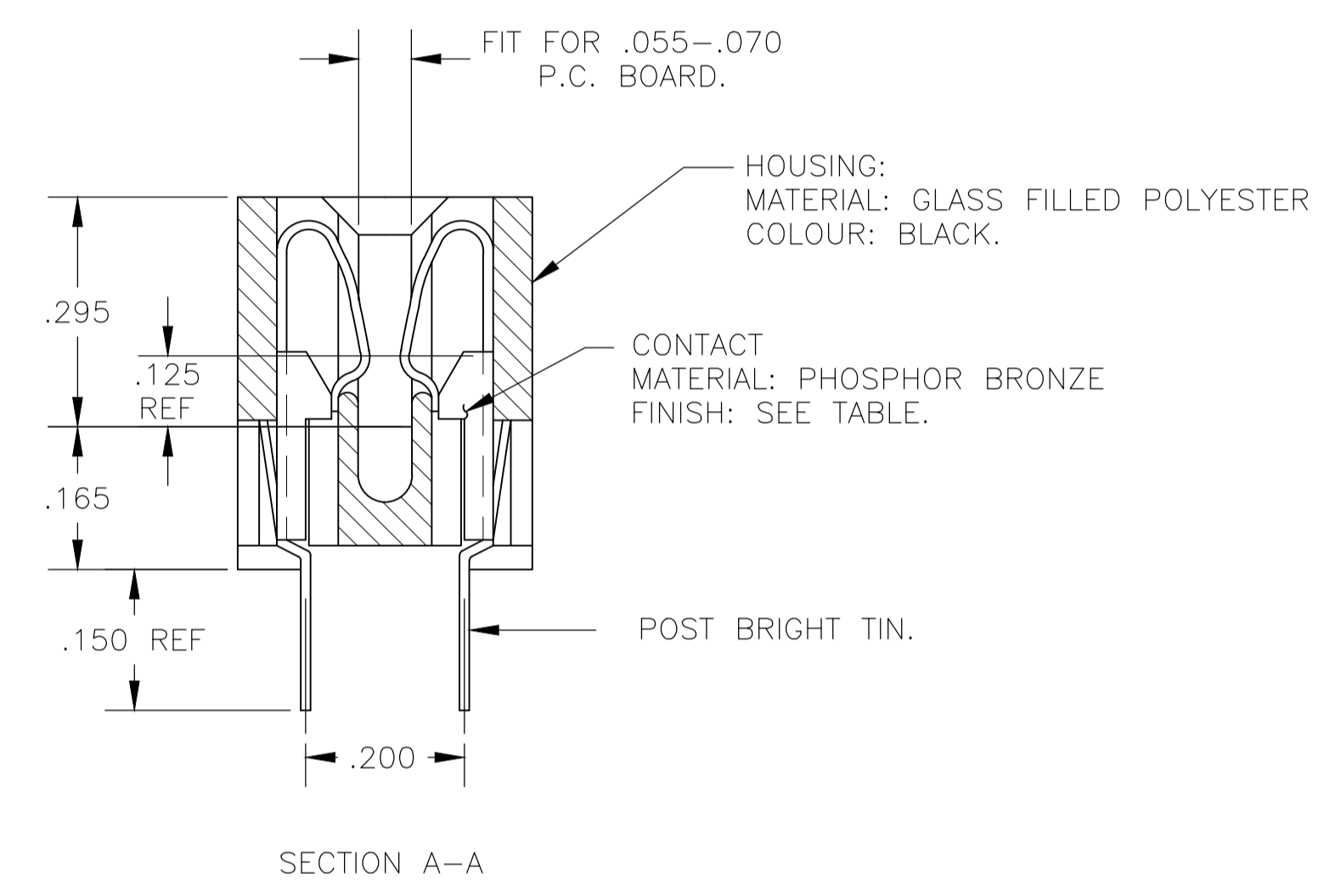

"AMP" PART NO & DATE CODE INK STAMPED WHITE OR HOT STAMP (NO WHITE TAPE) IN THIS AREA (SIDE OPTIONAL)

- 1 .000015 MIN GOLD OVER .000050 MIN. NICKEL IN CONTACT AREA.
- 2 .000030 MIN GOLD OVER .000050 MIN. NICKEL IN CONTACT AREA.
- 3 ALL PARTS ASSEMBLED IN MEXICO MUST BE STAMPED " ASSY IN MEXICO " THE WORD " MEXICO " CAN BE SUBSTITUTED ONLY WHERE PART SIZE PROHIBITS STAMPING " ASSY IN MEXICO ", INK STAMP COLOR WHITE OR HOT STAMP (NO WHITE TAPE) 115-9009, APPROX WHERE SHOWN SIDE OPTIONAL.
- 4 MATTE TIN PLATED CONTACT TAILS.
- 5 OBSOLETE PARTS: OBSOLETE CIS STREAMLINING PER D.RENAUD/D.SINISI

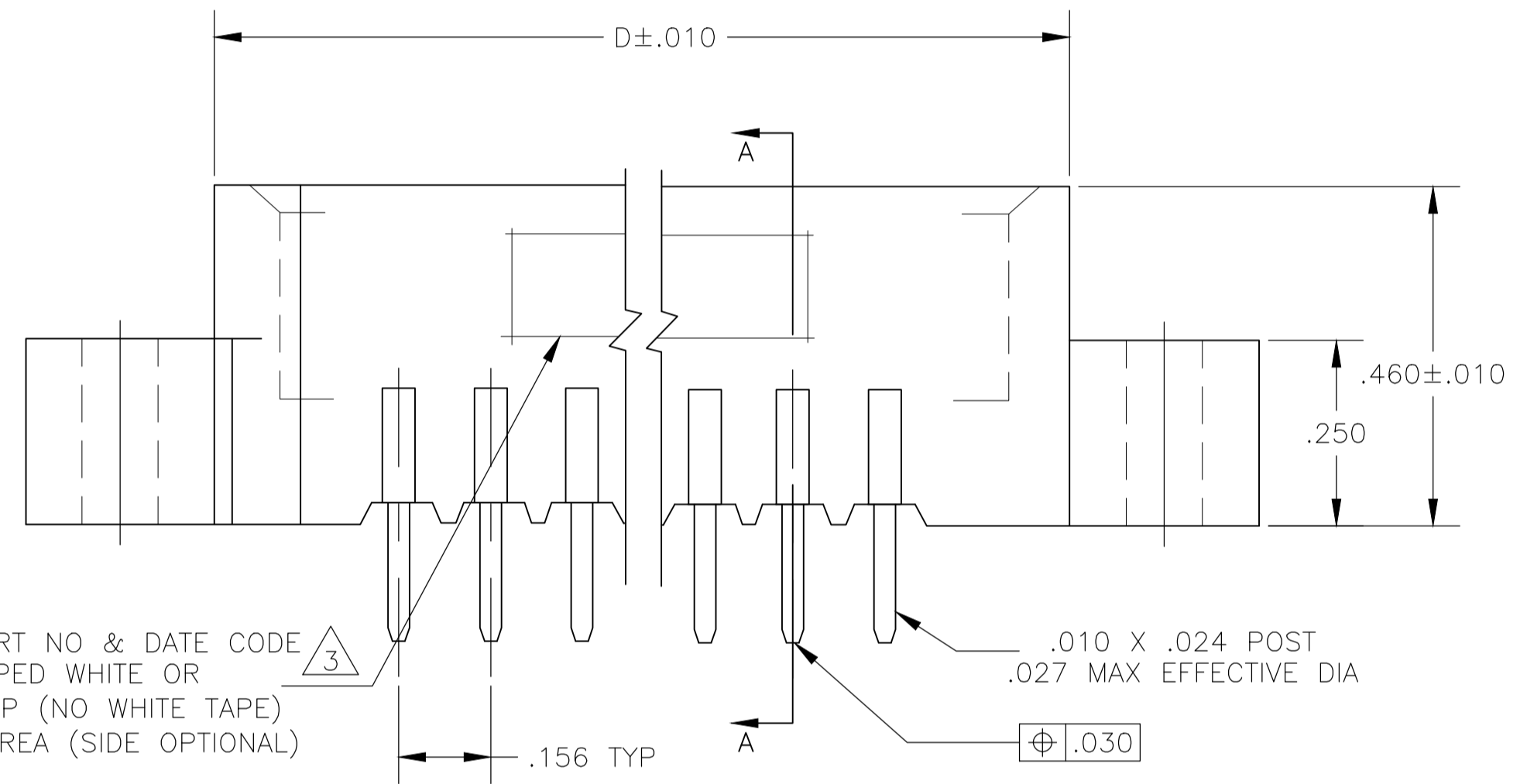
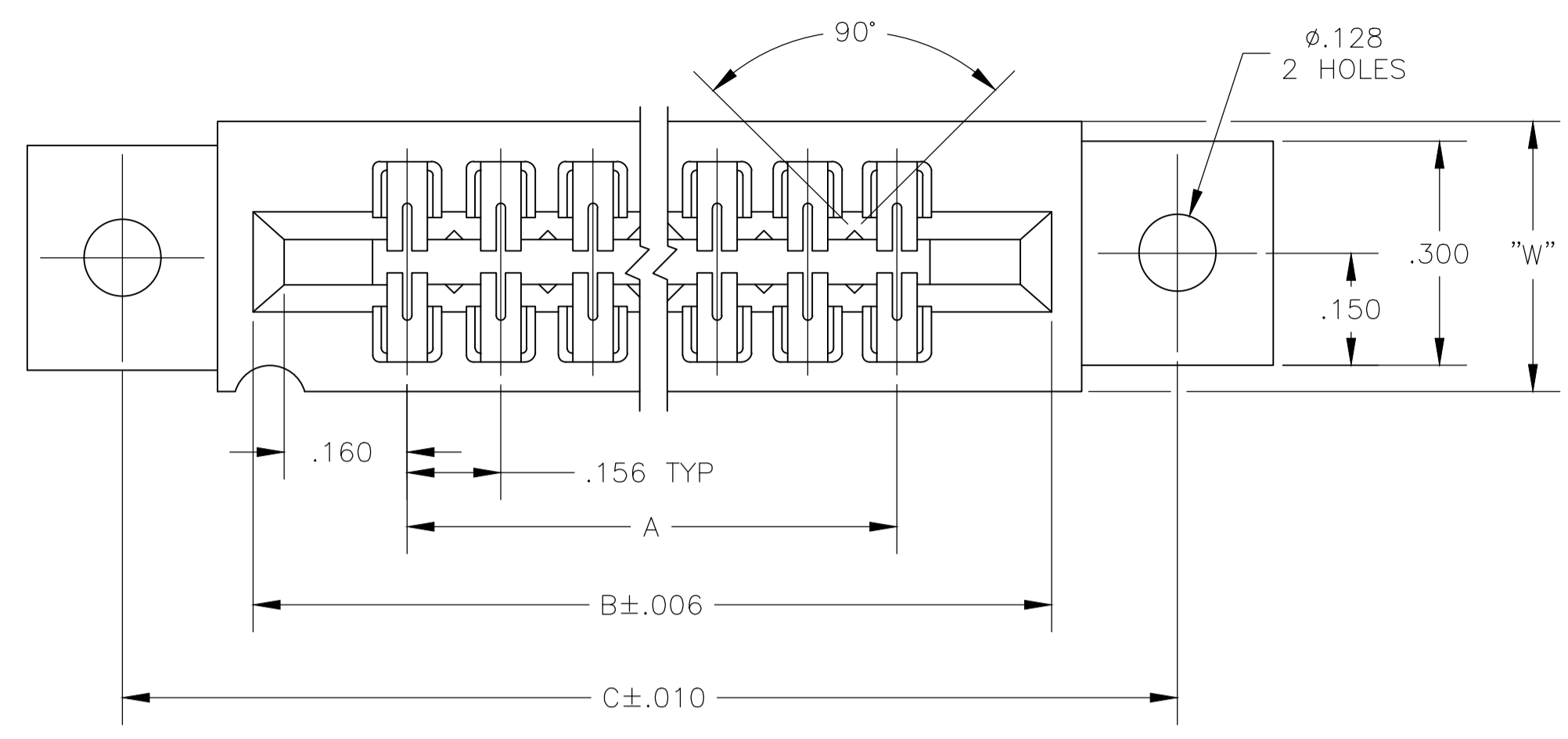
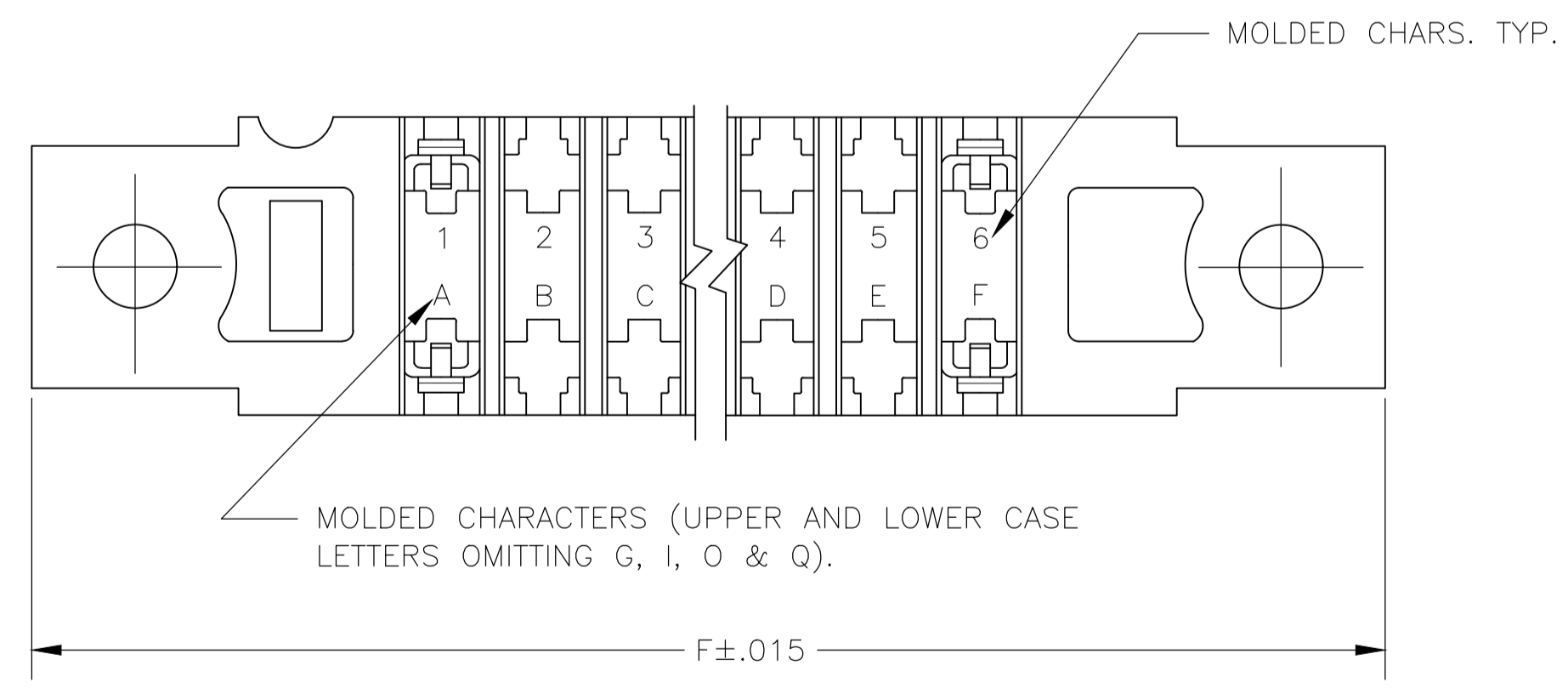

.437	8-530689-0	36	5.460	5.780	6.215	5.920	6.465	-
.437	7-530689-9	30	4.524	4.844	5.279	4.984	5.529	-
.370	7-530689-6	22	3.276	3.596	4.031	3.736	4.281	-
.370	7-530689-4	15	2.184	2.504	2.939	2.644	3.189	-
.370	7-530689-1	6	.780	1.100	1.535	1.240	1.785	-
.437	3-530689-3	43	6.552	6.872	7.307	7.012	7.557	1-530689-3
.370	3-530689-2	28	4.212	4.532	4.967	4.672	5.217	1-530689-2
.437	3-530689-1	44	6.708	7.028	7.463	7.168	7.713	1-530689-1
.437	3-530689-0	36	5.460	5.780	6.215	5.920	6.465	1-530689-0
.437	2-530689-9	30	4.524	4.844	5.279	4.984	5.529	530689-9
.370	2-530689-8	25	3.744	4.064	4.499	4.204	4.749	530689-8
.370	2-530689-7	24	3.588	3.908	4.343	4.048	4.593	530689-7
.370	2-530689-6	22	3.276	3.596	4.031	3.736	4.281	530689-6
.370	2-530689-5	18	2.652	2.972	3.407	3.112	3.657	530689-5
.370	2-530689-4	15	2.184	2.504	2.939	2.644	3.189	530689-4
.370	2-530689-3	12	1.716	2.036	2.471	2.176	2.721	530689-3
.370	2-530689-2	10	1.404	1.724	2.159	1.864	2.409	530689-2
.370	2-530689-1	6	.780	1.100	1.535	1.240	1.785	530689-1

OBSOLETE

W	2 PART NO	NO.OF. POSITION	A	B	C	D	E	1 PART NO
---	-----------	-----------------	---	---	---	---	---	-----------

THIS DRAWING IS A CONTROLLED DOCUMENT.

DIMENSIONS: INCHES

TOLERANCES UNLESS OTHERWISE SPECIFIED:

0 PLC	± .005
1 PLC	± .005
2 PLC	± .005
3 PLC	± .005
4 PLC	± .005
ANGLES	± .005

MATERIAL: SEE CALL-OUT

FINISH: SEE CALL-OUT

WEIGHT: 0.000000

CUSTOMER DRAWING

DIN: 15SEP75

CHK: 15SEP75

APVD: 16SEP75

NAME: HOUSING ASSY, LOW PROFILE, EDGE CONNECTOR, FLOW SOLDER, FOR .040 DIA. HOLE, .200 ROW, 156 CENTERS.

SIZE: A1

CAGE CODE: 00779

DRAWING NO: 530689

SCALE: 4:1

SHEET: 1 OF 1

REV: L2