

NOTES:

- 1.0 MATERIALS:
  - 1.1 HOUSING, LOCKWASHER & NUT: STAINLESS STEEL PER ASTM-A582, TYPE 303.
  - 1.2 DIELECTRIC: PTFE FLUOROCARBON PER ASTM-D1457.
  - 1.3 CENTER CONTACT: BERYLLIUM COPPER ROD ASTM-B194, ALLOY C172.
- 2.0 PLATING:
  - 2.1 HOUSING, LOCKWASHER & NUT: PASSIVATED PER MIL-F-14072.
  - 2.2 CENTER CONTACT: GOLD PER MIL-G-45204 TYPE II, CLASS 2.
- 3.0 MECHANICAL:
  - 3.1 INTERFACE: SMA PER MIL-STD-348A, FIG. 310-2; TNCA PER MIL-STD-348A, FIG. 313-4.
  - 3.2 CENTER CONTACT CAPTURED IN ACCORDANCE MIL-C-39012
- 4.0 DIMENSIONS IN PARENTHESIS ARE MILLIMETERS.
- 5.0 ELECTRICAL:
  - 5.1 FREQUENCY: DC - 18.0 GHz
  - 5.2 VSWR: 1.07+.015f (GHz)

MODEL NUMBER  
 ADT-2793-TF-SMF-02

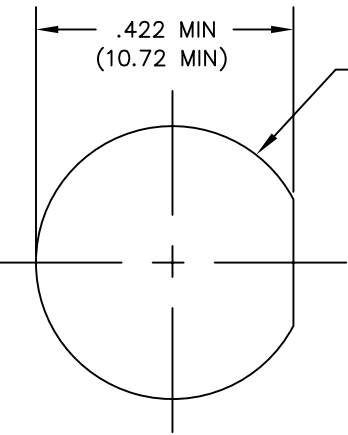
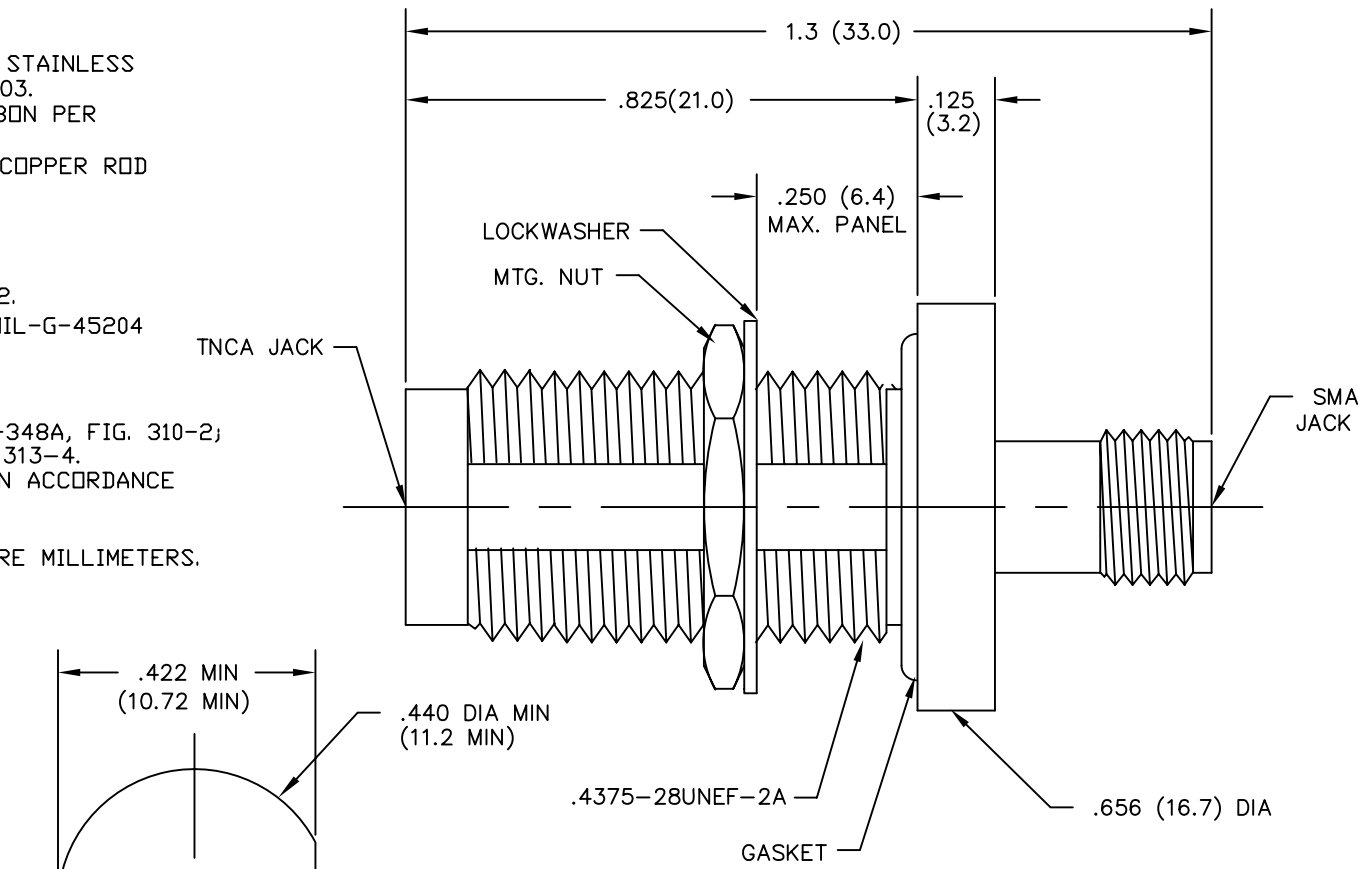

NOTICE: The information contained in this drawing is proprietary and must not be used without the permission of Emerson Network Power.

UNLESS OTHERWISE NOTED DIMENSIONS ARE IN INCHES AND TOLERANCES ARE:  
 3 PLACE DECIMALS ±.005  
 2 PLACE DECIMALS ±.02  
 FRACTIONS ±1/64  
 PARALLELITY: T.I.R.  
 FLATNESS: T.I.R.  
 CONCENTRICITY: T.I.R.  
 ANGLES AND PERPENDICULARITY: ±1°

CAGE CODE <b>34078</b>		<b>MIDWEST MICROWAVE</b>	
 <b>EMERSON</b> Network Power Connectivity Solutions		TITLE TNCA - SMA ADAPTER OUTLINE DRAWING	
		DRAWN/DATE D.SIEWERT 10/8/91	ENG./DATE H.JACQUES 10/8/91
CHECKED/DATE A.OSGA 10/8/91	APPROVED/DATE T.GORDON 10/8/91	DRAWING NUMBER ADT-2793-TF-SMF-02-01	REV. C
SCALE: 5=1		SHEET 1 of 1	

REV.	DESCRIPTION	DATE
1	RELEASED	10/8/91
A	EON 11269	11/25/91
B	EON 21526	4/27/07
C	EOO 21970	3/26/09