

Type: CDEP63ME

UNDER DEVELOPMENT

◆ **Product Description**

- 7.25 × 6.8mm Max. (L × W), 3.0mm Max. height.
- Inductance range: 0.33 μ H ~ 10 μ H.
- Rated Current Range: 2.1A ~ 13.5A.



◆ **Feature**

- Super high current inductors.
- Iron powder core used, Flat wire used.
- Ideally used in Server, Desktop and Notebook CPU power supply.
- RoHS Compliance.

◆ **Dimensions (mm)**

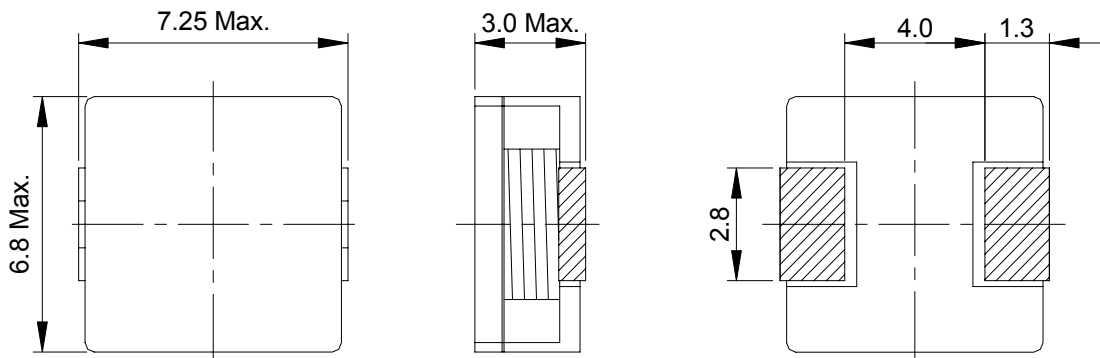

◆ **Land Pattern (mm)**

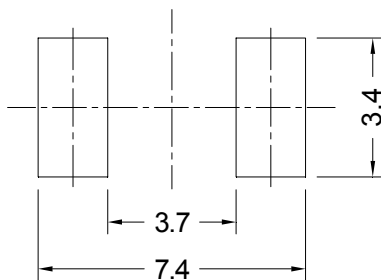

◆ **Schematics (Bottom)**

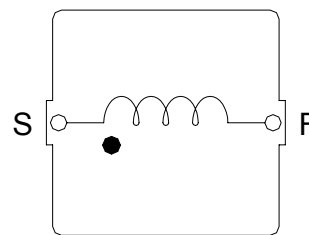

Type: CDEP63ME
◆ Specification

Part Name ※	Stamp	Inductance ※1	D.C.R.(mΩ) Max.(Typ.) (20°C)	Saturation Current (A) ※3	Temperature Rise current (A) ※4
CDEP63MENP-R33M□	R33	0.33 μ H±20%	4.0 (3.2)	26.0 (32.5)	13.5 (15.4)
CDEP63MENP-R47M□	R47	0.47 μ H±20%	5.9 (4.7)	28.8 (36.0)	11.6 (13.2)
CDEP63MENP-R68M□	R68	0.68 μ H±20%	9.2 (7.3)	23.2 (29.0)	9.0 (10.0)
CDEP63MENP-R82M□	R82	0.82 μ H±20%	9.2 (7.3)	16.9 (21.2)	9.0 (10.0)
CDEP63MENP-1R0M□	1R0	1.0 μ H±20%	14.0 (11.2)	21.2 (26.5)	7.2 (8.2)
CDEP63MENP-1R5M□	1R5	1.5 μ H±20%	20.0 (16.0)	14.2 (17.8)	5.2 (6.2)
CDEP63MENP-2R2M□	2R2	2.2 μ H±20%	26.0 (20.8)	10.2 (12.8)	4.3 (4.8)
CDEP63MENP-3R3M□	3R3	3.3 μ H±20%	53.4 (42.7)	10.6 (13.3)	3.2 (3.6)
CDEP63MENP-4R7M□	4R7	4.7 μ H±20%	59.3 (47.4)	7.4 (9.2)	2.9 (3.3)
CDEP63MENP-6R8M□	6R8	6.8 μ H±20%	85.5 (68.4)	6.1 (7.6)	2.5 (2.9)
CDEP63MENP-8R2M□	8R2	8.2 μ H±20%	90.5 (72.4)	5.8 (7.2)	2.4 (2.7)
CDEP63MENP-100M□	100	10 μ H±20%	113.8 (91.0)	4.6 (5.8)	2.1 (2.3)

※ Description of part name

CDEP63MENP-R47M□

- B Box
- C Carrier Tape

※1 Measured at 100KHz, 0.25Vrms.

※2 () Typical value.

※3 This indicates the value of current when the inductance is 20% lower than its initial value at D.C. superposition.

※4 The DC current at which the temperature rise is Δt=40°C.(Ta=20°C).