

DWG. NO. SD-35718-001
 SIMILAR ITEM
 PROJECT NO.
 DO NOT SCALE DRAWING DIMENSION IN METRIC

8 7 6 5 4 3 2 1

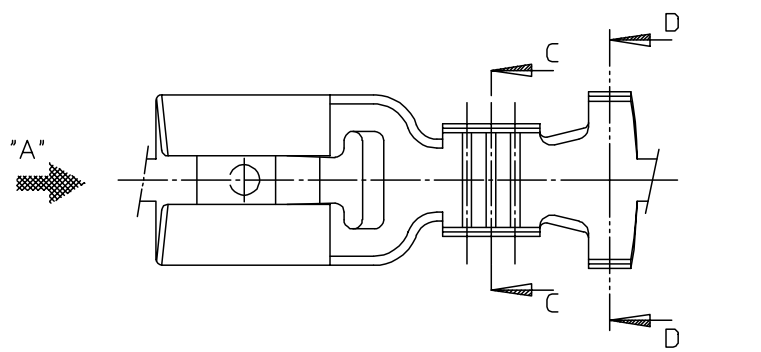

MATERIAL NO.	ENG NO.	a	b	c	d	WIRE RANGE
357181610	35718-1610	2.1	2.2	3.9	3.9	AWG #24-#22
357181710	35718-1710	3.2	3.4	5.3	5.2	AWG #20-#16
357181810	35718-1810	4.0	4.0	--	--	AWG #20-#20
						AWG #18-#20
						AWG #18-#18

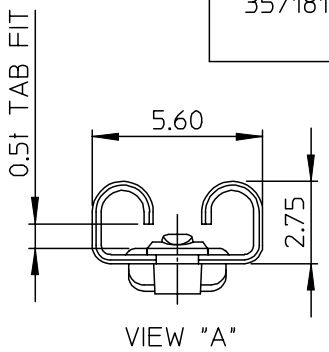
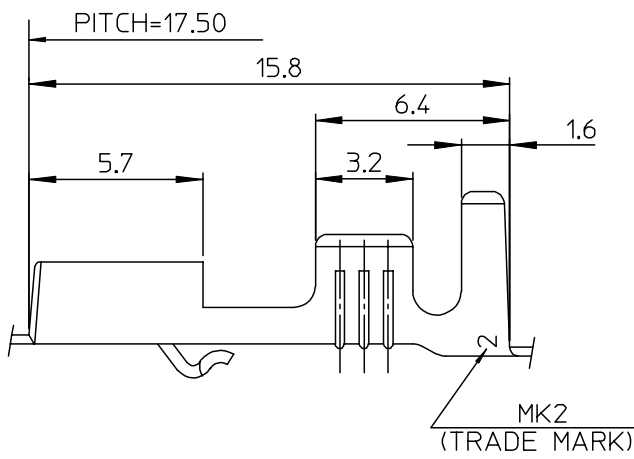

- NOTES
1. MATERIAL : BRASS,0.30mm THICKNESS
 2. FINISH : PRE-PLATED TIN
 3. MATING TAB THICKNESS: 0.5mm
 4. RECOMMENDED LENGTH OF WIRE STRIP IS 4.5-5.0mm

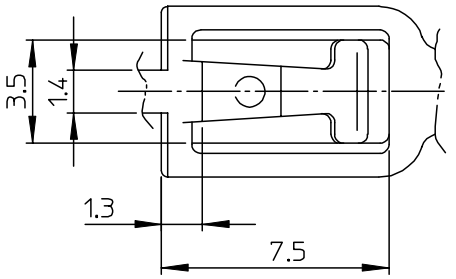
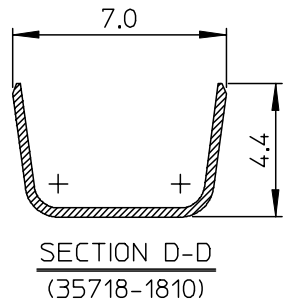
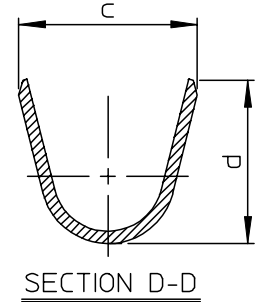
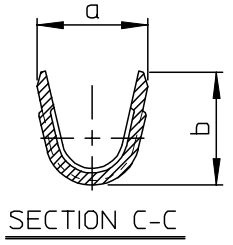

REDRAWN ECN NO. KOR2004-0079 DRWN: C.B.CHIN 03/12/08 CHK: W.Y.YANG APPR: C.W.LEE	DESCRIPTION MAJOR $\nabla = 0$ CRITICAL $\nabla C = 0$	GENERAL TOLERANCES: (UNLESS SPECIFIED)		SCALE 5:1	DESIGN UNITS <input checked="" type="checkbox"/> mm <input type="checkbox"/> INCH	<input checked="" type="checkbox"/> THIRD ANGLE <input type="checkbox"/> FIRST ANGLE PROJECTION	DIMENSIONS: <input type="checkbox"/> mm <input type="checkbox"/> INCH <input checked="" type="checkbox"/> mm ONLY	SHT REV
		4 PLACES $\pm 0.$ $\pm -$	DRAWN BY & DATE J.S.KANG 94/01/04	TITLE: .187 SAFE LOCK RECEPTACLE				
		3 PLACES $\pm 0.$ $\pm -$	CHECKED BY & DATE B.K.CHOI 94/01/04					
		2 PLACES ± 0.30 $\pm -$	APPROVED BY & DATE C.W.LEE 94/01/04	MOLEX INCORPORATED				
1 PLACE ± 0.30 $\pm -$	CAD FILENAME S7181610AAMI	MATERIAL NO. SEE CHART	DRAWING NO. SD-35718-001				SHEET NO. 1 OF 1	
B	REV	DRAFT WHERE APPLICABLE MUST REMAIN WITHIN DIMENSIONS		THIS DRAWING CONTAINS INFORMATION THAT IS PROPRIETARY TO MOLEX INCORPORATED AND SHOULD NOT BE USED WITHOUT WRITTEN PERMISSION.			SIZE B	

8 7 6 5 4 3 2 1

KOREA MX-A3