

Features

- 0603 0.4mm SMD LED
- High Brightness
- AllnGaP / InGaN Technology
- Small package
- High reliability
- Clear Lens

Applications

- Consumer Electronics
- Wearables
- Automobile After Market
- Industrial Equipment

Description

The IN-S63AT series is a popular low profile 0603 package with versatile design capabilities. It is a PCB type molding style LED which can be used in various applications.

Recommended Solder Pattern

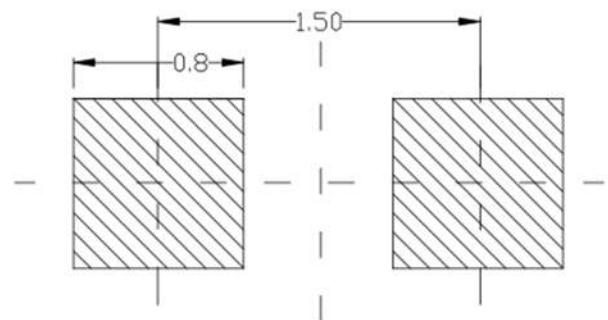
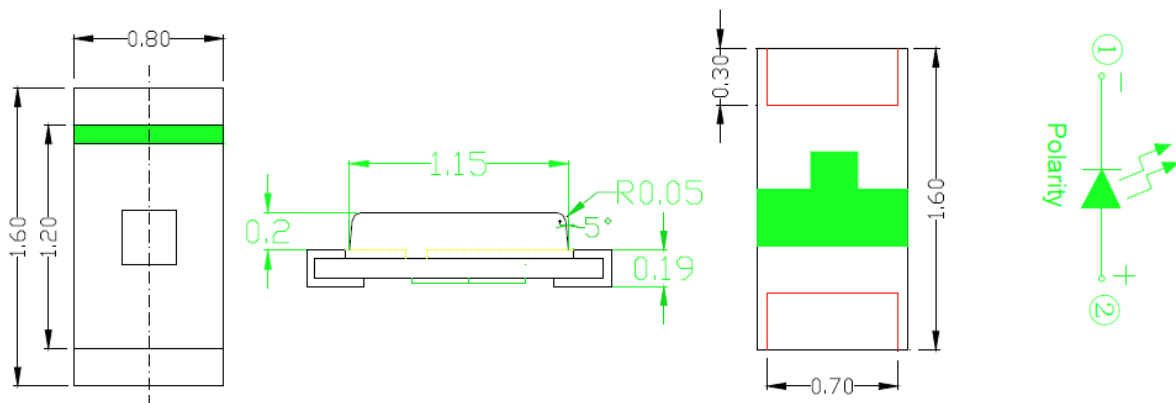

Figure 1. IN-S63AT Solder Pattern

Package Dimensions in mm



Notes.

1. All dimensions are in millimeters.
2. Tolerance is ± 0.10 mm unless otherwise noted

Figure 2. IN-S63AT Package Dimensions

Absolute Maximum Rating at 25°C (Note 1)

Product	Emission Color	P_d (mW)	I_f (mA)	I_{FP}^* (mA)	V_R (V)	T_{OP} (°C)	T_{ST} (°C)
IN-S63AT5YG	Yellow Green	75	25	70	5	-40°C~+85°C	-40°C~+90°C
IN-S63AT5Y	Yellow						
IN-S63AT5A	Amber						
IN-S63ATR	Red						
IN-S63AT5B	Blue	75	25	100			
IN-S63AT5G	Green						
IN-S63AT5UW	White						

Notes

1. Condition for IFP is pulse of 1/10 duty and 0.1msec width

ESD Precaution

ATTENTION: Electrostatic Discharge (ESD) protection



The symbol above denotes that ESD precaution is needed. ESD protection for GaP and AlGaAs based chips is necessary even though they are relatively safe in the presence of low static-electric discharge. Parts built with AlInGaP, GaN, or/and InGaN based chips are STATIC SENSITIVE devices. ESD precaution must be taken during design and assembly. If manual work or processing is needed, please ensure the device is adequately protected from ESD during the process.

Please be advised that normal static precautions should be taken in the handling and assembly of this device to prevent damage or degradation which may be induced by electrostatic discharge (ESD).

Electrical Characteristics $T_A = 25^\circ\text{C}$ (Note 1)

Product	Emission Color	$I_F(\text{mA})$	$V_F(\text{V})$	$\lambda(\text{nm})$			Viewing Angel	$I_v(\text{mcd})$
			typ.	λ_D	λ_P	$\Delta\lambda$	$2\theta_{1/2}$	typ.
IN-S63AT5YG	Yellow Green	5	2.0	573	574	15	120	11.5
IN-S63AT5Y	Yellow	5	2.0	589	593	30	120	35
IN-S63AT5A	Amber	5	2.0	605	609	30	120	35
IN-S63ATR	Red	20	2.2	622	636	30	120	120
IN-S63AT5B	Blue	5	2.8	470	468	30	120	45
IN-S63AT5G	Green	5	2.7	525	530	35	120	285
IN-S63AT5UW	White	5	2.8	X=0.29 Y=0.29	-	-	120	285

Notes

1. Performance guaranteed only under conditions listed in above tables.

Chromaticity Bin (for White only)

Bin Code	CIE-X	CIE-Y	Bin Code	CIE-X	CIE-Y	Bin Code	CIE-X	CIE-Y	Bin Code	CIE-X	CIE-Y
Z4	0.27	0.291	Z3	0.26	0.271	Z2	0.25	0.251	Z1	0.24	0.231
	0.28	0.311		0.27	0.291		0.26	0.271		0.25	0.251
	0.283	0.305		0.2735	0.286		0.264	0.267		0.2545	0.248
	0.2735	0.286		0.264	0.267		0.2545	0.248		0.245	0.2291
B5	0.2735	0.2860	B1	0.2640	0.2670	A5	0.2545	0.2480	A1	0.2497	0.2267
	0.2772	0.2800		0.2680	0.2623		0.2589	0.2445		0.2450	0.2290
	0.2863	0.2978		0.2772	0.2800		0.2680	0.2623		0.2545	0.2480
	0.2830	0.3050		0.2735	0.2860		0.2640	0.2670		0.2589	0.2445
B6	0.2772	0.2800	B2	0.2720	0.2575	A6	0.2589	0.2445	A2	0.2497	0.2267
	0.2808	0.2740		0.2680	0.2623		0.2633	0.2410		0.2589	0.2445
	0.2895	0.2905		0.2772	0.2800		0.2720	0.2575		0.2633	0.2410
	0.2863	0.2978		0.2808	0.2740		0.2680	0.2623		0.2545	0.2245
B7	0.2808	0.2740	B3	0.2720	0.2575	A7	0.2677	0.2375	A3	0.2593	0.2223
	0.2844	0.2680		0.2760	0.2528		0.2633	0.2410		0.2677	0.2375
	0.2928	0.2833		0.2844	0.2680		0.2720	0.2575		0.2633	0.2410
	0.2895	0.2905		0.2808	0.2740		0.2760	0.2528		0.2545	0.2245
B8	0.2844	0.2680	B4	0.2760	0.2528	A8	0.2720	0.2340	A4	0.2640	0.2200
	0.2928	0.2833		0.2844	0.2680		0.2677	0.2375		0.2593	0.2223
	0.2960	0.2760		0.2880	0.2620		0.2760	0.2528		0.2677	0.2375
	0.2880	0.2620		0.2800	0.2480		0.2800	0.2480		0.2720	0.2340
AF	0.2300	0.2110	AA	0.22	0.191	Z5	0.2800	0.3110	C5	0.2883	0.3172
	0.2355	0.2102		0.226	0.1913		0.2871	0.3210		0.2870	0.3210
	0.2450	0.2291		0.2355	0.2102		0.2895	0.3134		0.2937	0.3312
	0.2400	0.2310		0.23	0.211		0.2830	0.3050		0.2950	0.3266
AG	0.2355	0.2102	AB	0.226	0.1913	C1	0.2830	0.3050	C6	0.2883	0.3172
	0.2405	0.2089		0.2313	0.1911		0.2863	0.2978		0.2950	0.3266
	0.2497	0.2267		0.2405	0.2089		0.2923	0.3052		0.2962	0.3220
	0.2450	0.2291		0.2355	0.2102		0.2895	0.3134		0.2895	0.3134
AH	0.2405	0.2089	AC	0.2313	0.1911	C2	0.2863	0.2978	C7	0.2895	0.3134
	0.2457	0.2080		0.2369	0.1915		0.2895	0.2905		0.2908	0.3097
	0.2545	0.2245		0.2457	0.208		0.2950	0.2970		0.2973	0.3177
	0.2497	0.2267		0.2405	0.2089		0.2923	0.3052		0.2962	0.3220
AI	0.2457	0.2080	AD	0.2369	0.1915	C3	0.2895	0.2905	C8	0.2908	0.3097
	0.2509	0.2071		0.2425	0.1919		0.2928	0.2833		0.2920	0.3060
	0.2593	0.2223		0.2509	0.2071		0.2977	0.2891		0.2984	0.3133
	0.2545	0.2245		0.2457	0.208		0.2950	0.2970		0.2973	0.3177
AJ	0.2509	0.2071	AE	0.2425	0.1919	C4	0.2928	0.2833	D1	0.2920	0.3060
	0.2560	0.2060		0.2480	0.1920		0.2977	0.2891		0.2935	0.3015
	0.2640	0.2200		0.2560	0.2060		0.3003	0.2812		0.2997	0.3088
	0.2593	0.2223		0.2509	0.2071		0.2960	0.2760		0.2984	0.3133
D2	0.2935	0.3015	D3	0.2950	0.2970	D4	0.2965	0.2925	D5	0.2937	0.3312
	0.2950	0.2970		0.2965	0.2925		0.2980	0.2880		0.2950	0.3266
	0.3009	0.3042		0.3023	0.2990		0.3037	0.2937		0.3017	0.3360
	0.2997	0.3088		0.3009	0.3042		0.3023	0.2990		0.3005	0.3415

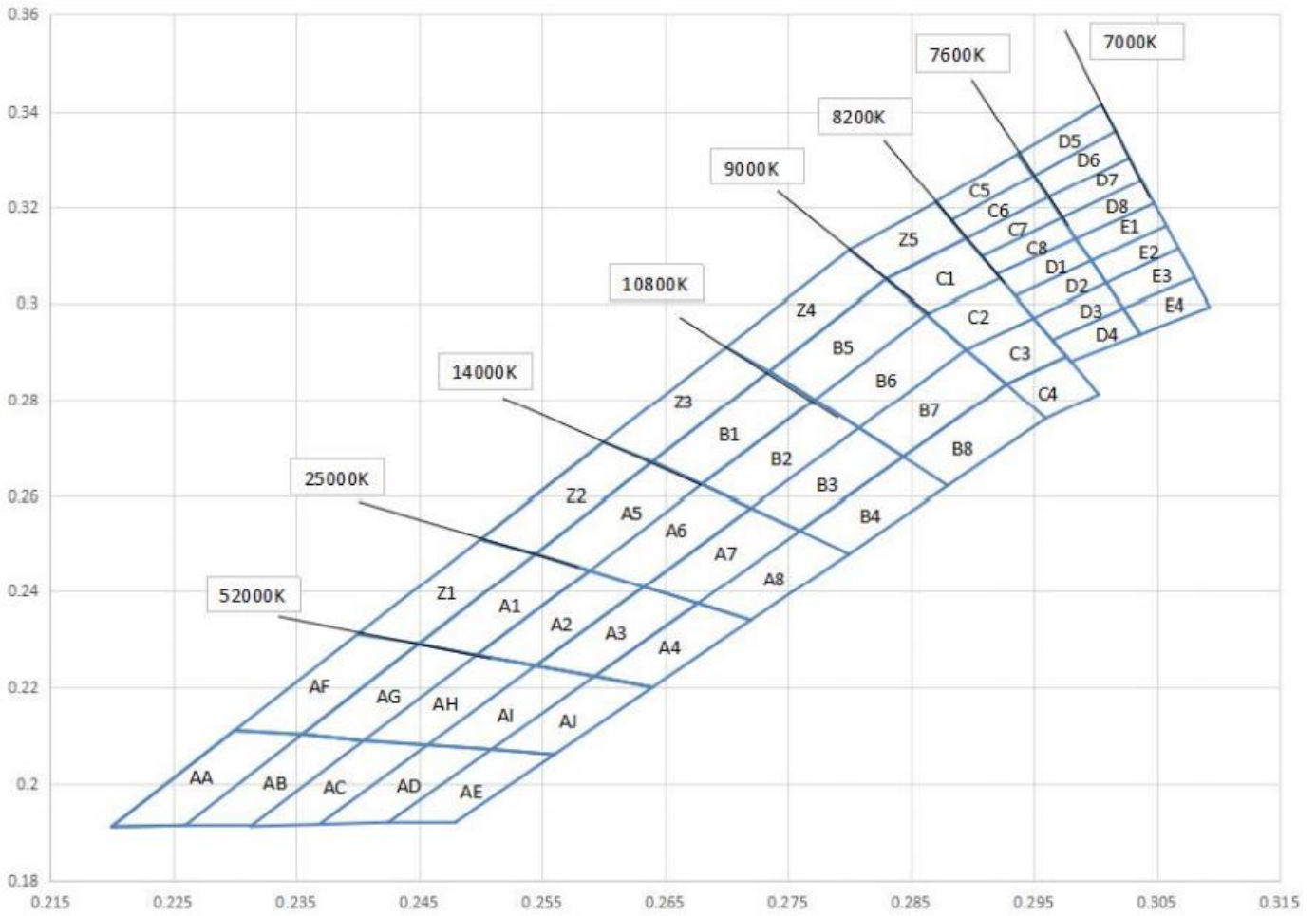

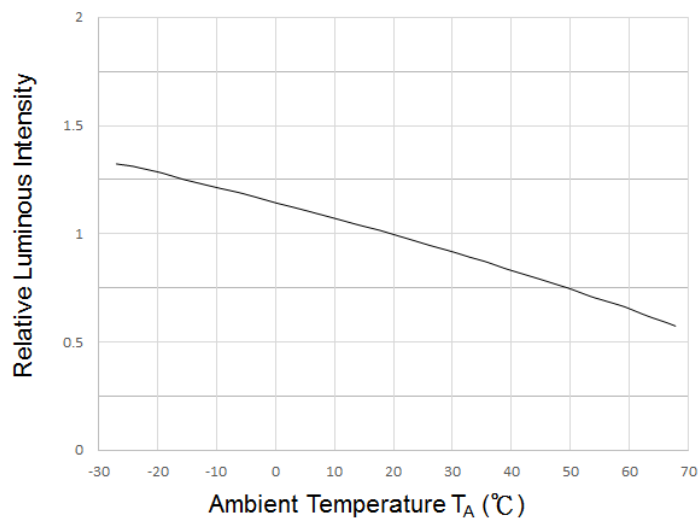
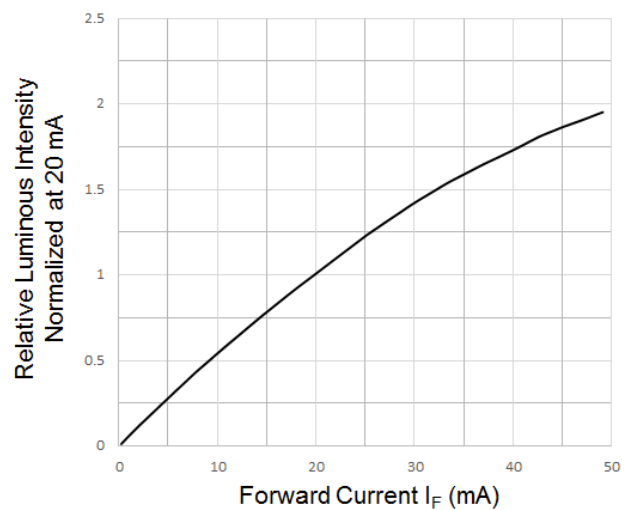
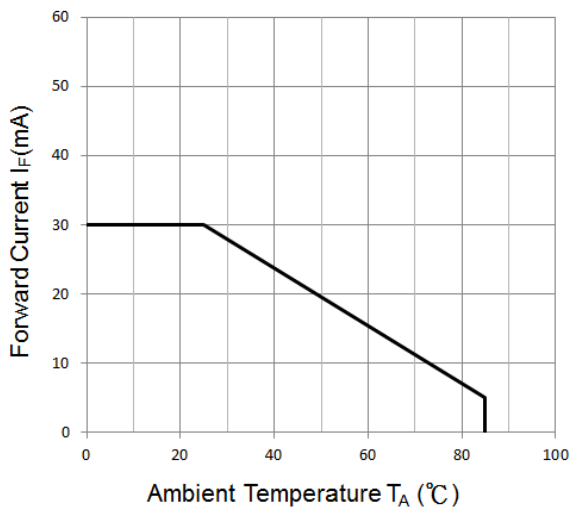
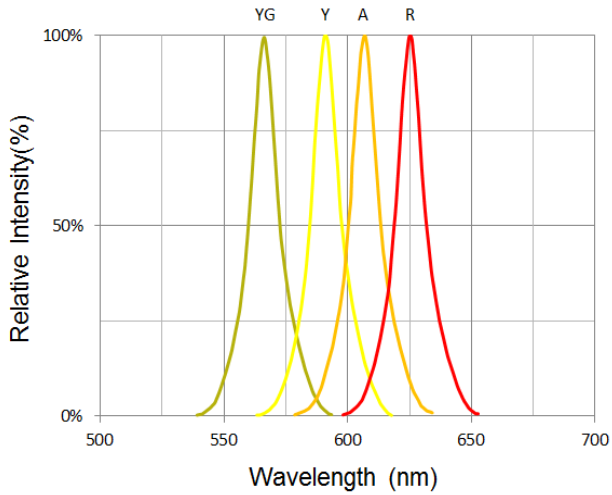
Typical Characteristic Curves – YG, Y, A, R

Typical Characteristic Curves – B, G, W

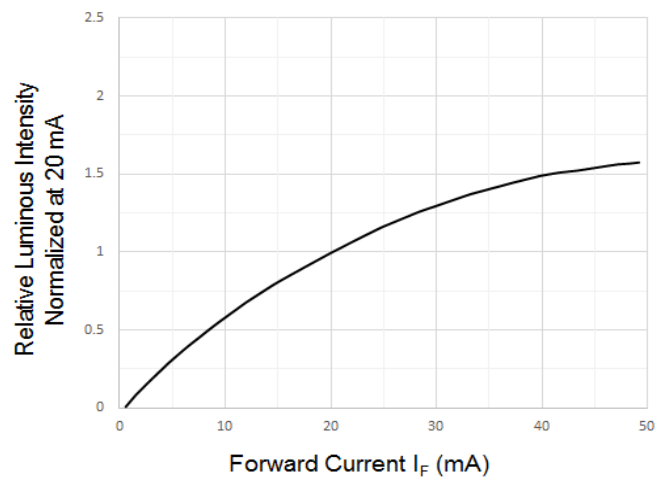
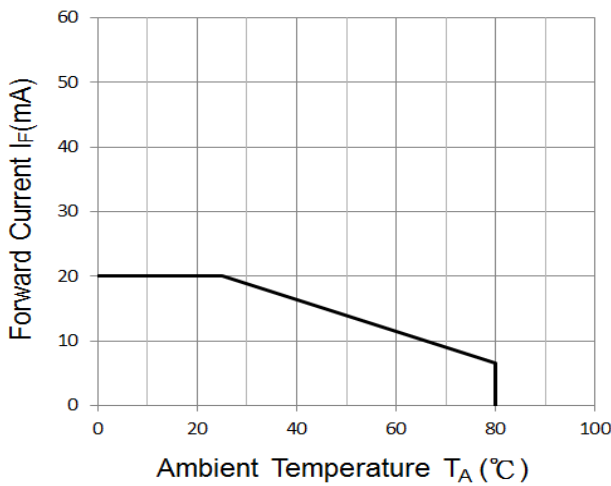
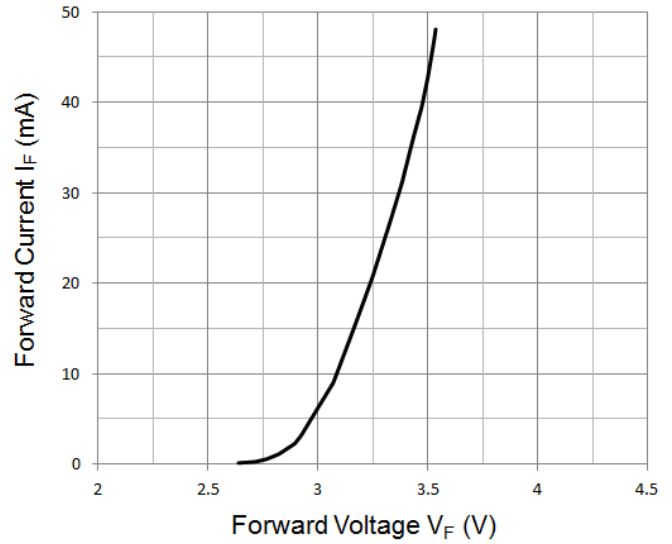
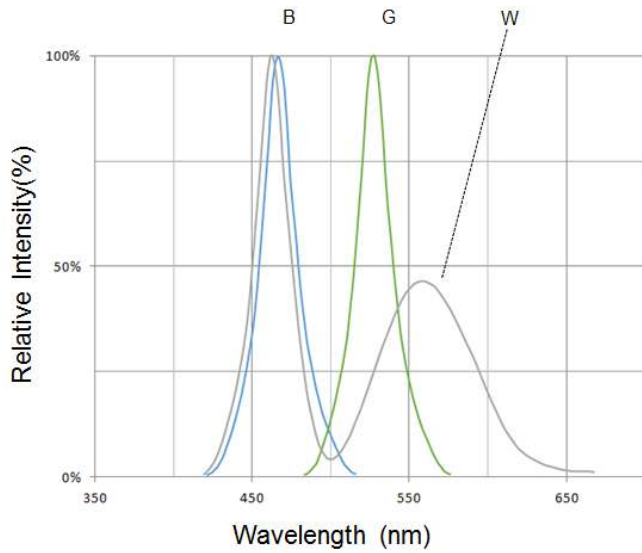

Typical Characteristic Curves – Radiation Pattern

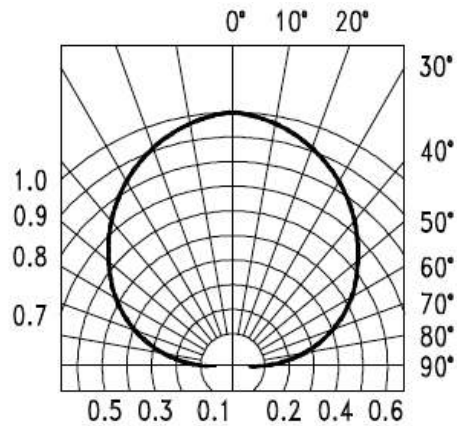

Ordering Information

Product	Emission Color	Technology	Test Current I_F (mA)	Luminous Intensity I_v (mcd) (Typ.)	Forward Voltage V_F (V) (Typ.)	Orderable Part Number
IN-S63AT5YG	Yellow Green	AllnGaP	5	11.5	2.0	IN-S63AT5YG
IN-S63AT5Y	Yellow	AllnGaP	5	35	2.0	IN-S63AT5Y
IN-S63AT5A	Amber	AllnGaP	5	35	2.0	IN-S63AT5A
IN-S63ATR	Red	AllnGaP	20	120	2.2	IN-S63ATR
IN-S63AT5B	Blue	InGaN	5	45	2.8	IN-S63AT5B
IN-S63AT5G	Green	InGaN	5	285	2.7	IN-S63AT5G
IN-S63AT5UW	White	InGaN	5	285	2.8	IN-S63AT5UW

Label Specifications

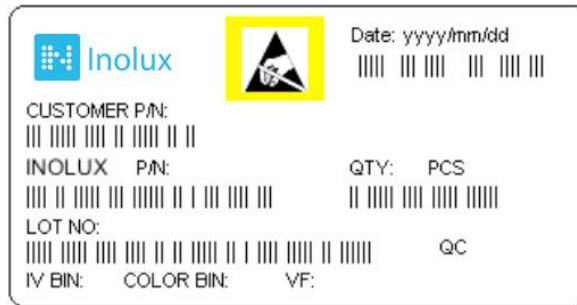

Inolux P/N:

I	N	-	S	6	3	A	T			X	-	X	X	X	X
Inolux SMD			Material	Package		Variation	Orientation	Current	Lens	Color		Customized Stamp-off			
			S = PCB Type	63A = 1.6 x 0.8 x 0.4mm			T = Top Mount	(Blank) = 20mA 5=5mA	(Blank) = Clear U = Diffused	R=622nm A=609nm Y=593nm YG=574nm G=530nm B=468nm W=White					

Lot No.:

Z	2	0	1	7	01	24	001
Internal Tracker	Year (2017, 2018,)				Month	Date	Serial

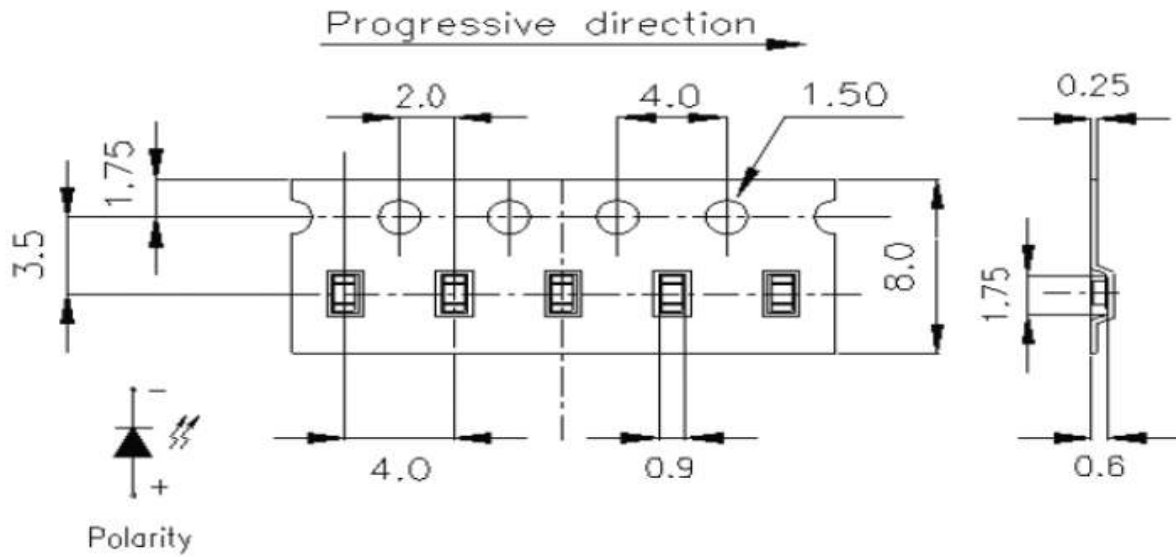
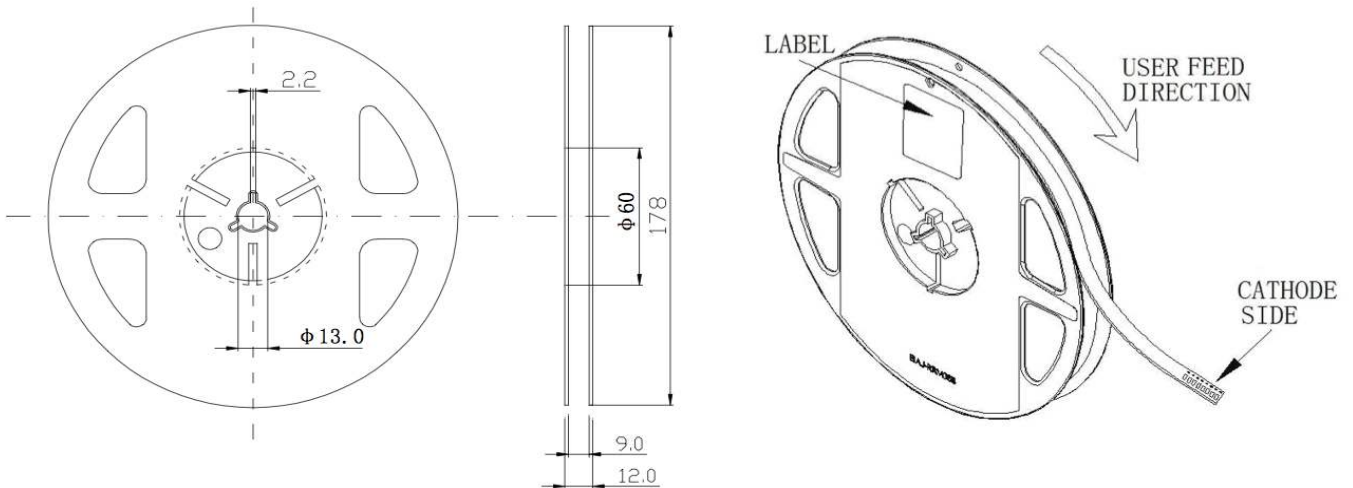
Packaging Information: 4000pcs Per Reel
Tape Dimension

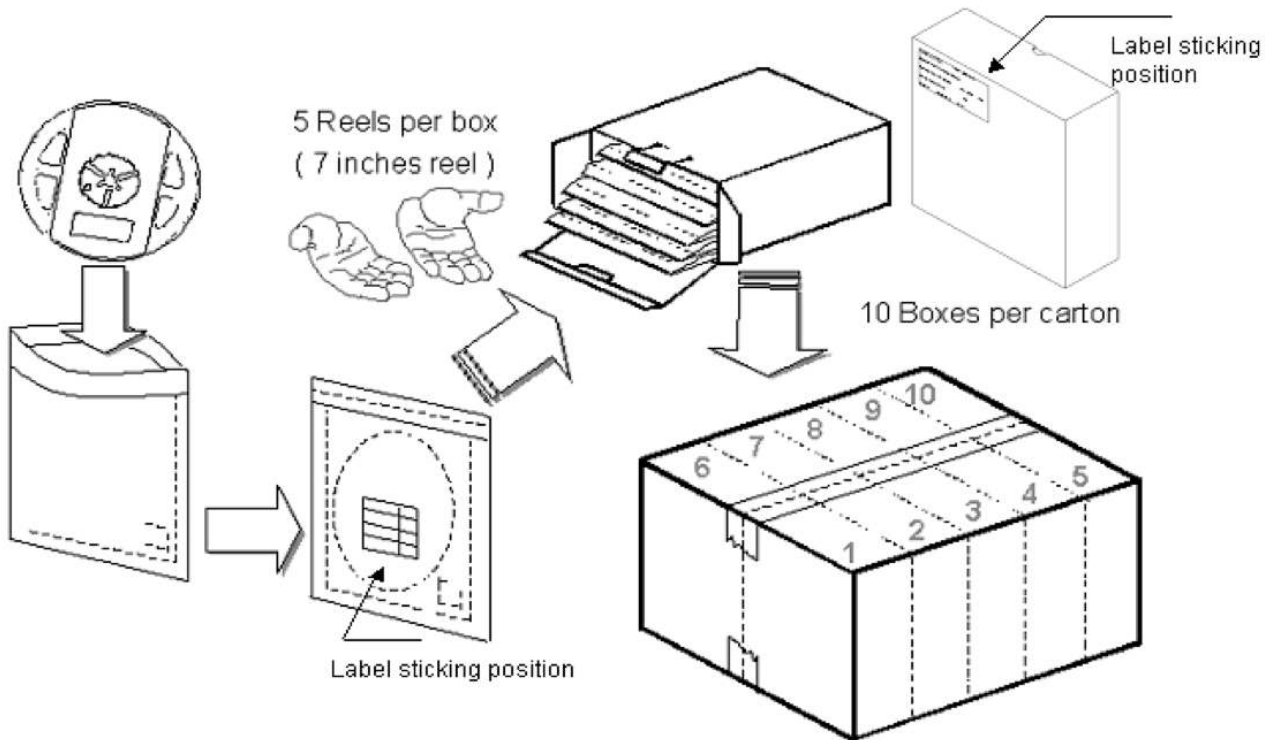
Reel Dimension

Packing Dimension

5 boxes per carton are available depending on shipment quantity.

	Specification	Material	Quantity
Carrier tape	Per EIA 481-1A specs	Conductive black tape	4000pcs per reel
Reel	Per EIA 481-1A specs	Conductive black	
Label	IN standard	Paper	
Packing bag	220x240mm	Aluminum laminated bag/ no-zipper	One reel per bag
Carton	IN standard	Paper	Non-specified

Others:

Each immediate box consists of 5 reels. The 5 reels may not necessarily have the same lot number or the same bin combinations of I_v , λ_D and V_f . Each reel has a label identifying its specification; the immediate box consists of a product label as well.

Dry Pack

All SMD optical devices are **MOISTURE SENSITIVE**. Avoid exposure to moisture at all times during transportation or storage. Every reel is packaged in a moisture protected anti-static bag. Each bag is properly sealed prior to shipment.

Upon request, a humidity indicator will be included in the moisture protected anti-static bag prior to shipment.

The packaging sequence is as follows:

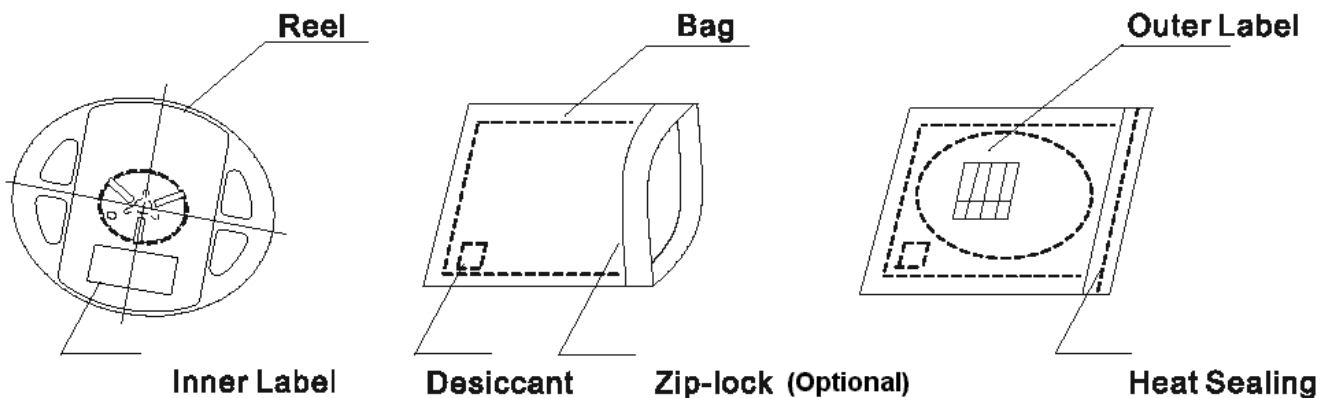

Reflow Soldering

- Recommended tin glue specifications: melting temperature in the range of 178~192 °C
- The recommended reflow soldering profile is as follows (temperatures indicated are as measured on the surface of the LED resin):

Lead-free Solder Profile

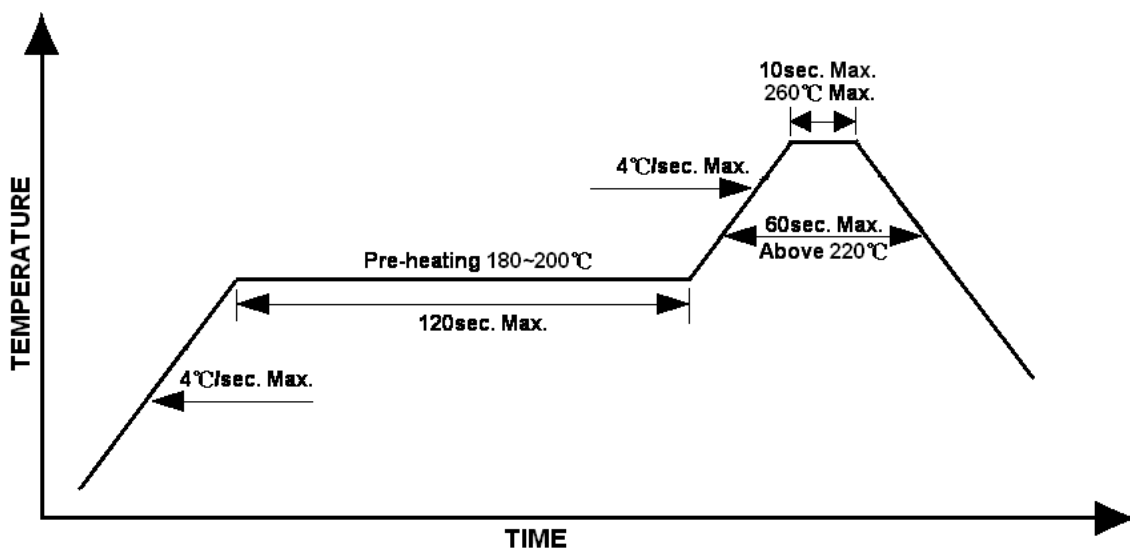

Precautions

- Avoid exposure to moisture at all times during transportation or storage.
- Anti-Static precaution must be taken when handling GaN, InGaN, and AlInGaP products.
- It is suggested to connect the unit with a current limiting resistor of the proper size. Avoid applying a reverse voltage.
- Avoid operation beyond the limits as specified by the absolute maximum ratings.
- Avoid direct contact with the surface through which the LED emits light.
- If possible, assemble the unit in a clean room or dust-free environment.

Reworking

- Rework should be completed within 5 seconds under 260 °C.
- The iron tip must not come in contact with the copper foil.
- Twin-head type is preferred.

Cleaning

Following are cleaning procedures after soldering:

- An alcohol-based solvent such as isopropyl alcohol (IPA) is recommended.
- Temperature x Time should be 50°C x 30sec. or <30°C x 3min
- Ultra sonic cleaning: < 15W/ bath; bath volume ≤ 1liter
- Curing: 100 °C max, <3min

Cautions of Pick and Place

- Avoid stress on the resin at elevated temperature.
- Avoid rubbing or scraping the resin by any object.
- Electro-static may cause damage to the component. Please ensure that the equipment is properly grounded. Use of an ionizer fan is recommended.

Reliability

Item	Frequency/ lots/ samples/ failures	Standards Reference	Conditions
Precondition	For all reliability monitoring tests according to JEDEC Level 2	J-STD-020	1.) Baking at 85°C for 24hrs 2.) Moisture storage at 85°C/ 60% R.H. for 168hrs
Solderability	1Q/ 1/ 22/ 0	JESD22-B102-B And CNS-5068	Accelerated aging 155°C/ 24hrs Tinning speed: 2.5+0.5cm/s Tinning: A: 215°C/ 3+1s or B: 260°C/ 10+1s
Resistance to soldering heat		CNS-5067	Dipping soldering terminal only Soldering bath temperature A: 260+/-5°C; 10+/-1s B: 350+/-10°C; 3+/-0.5s
Operating life test	1Q/ 1/ 40/ 0	CNS-11829	1.) Precondition: 85°C baking for 24hrs 85°C/ 60%R.H. for 168hrs 2.) Tamb25°C; IF=20mA; duration 1000hrs
High humidity, high temperature bias	1Q/ 1/ 45/ 0	JESD-A101-B	Tamb: 85°C Humidity: 85% R.H., IF=5mA Duration: 1000hrs
High temperature bias	1Q/ 1/ 20	IN specs.	Tamb: 55°C IF=20mA Duration: 1000hrs
Pulse life test	1Q/ 1/ 40/ 0		Tamb25°C, If=20mA,, Ip=100mA, Duty cycle=0.125 (tp=125 μs, T=1sec) Duration 500hrs)
Temperature cycle	1Q/ 1/ 76/ 0	JESD-A104-A IEC 68-2-14, Nb	A cycle: -40 degree C 15min; +85 degree C 15min Thermal steady within 5 min.. 300 cycles 2 chamber/ Air-to-air type
High humidity storage test	1Q/ 1/ 40/ 0	CNS-6117	60+3°C 90+5/-10% R.H. for 500hrs
High temperature storage test	1Q/ 1/ 40/ 0	CNS-554	100+10°C for 500hrs
Low temperature storage test	1Q/ 1/ 40/ 0	CNS-6118	-40+5°C for 500hrs

Revision History

Changes since last revision	Page	Version No.	Revision Date
Initial Release		1.0	02-07-2017
Revise the flux of IN-S63AT5UW	3, 8	1.1	07-10-2017
Revise the drawing	1	1.2	11-28-2017
Update	3,8	1.3	08-20-2019
Updated (new standard)	3,8	1.4	09-01-2021

DISCLAIMER

INOLUX reserves the right to make changes without further notice to any products herein to improve reliability, function or design. INOLUX does not assume any liability arising out of the application or use of any product or circuit described herein; neither does it convey any license under its patent rights, nor the rights of others.

LIFE SUPPORT POLICY

INOLUX's products are not authorized for use as critical components in life support devices or systems without the express written approval of the President of INOLUX or INOLUX CORPORATION. As used herein:

1. Life support devices or systems are devices or systems which, (a) are intended for surgical implant into the body, or (b) support or sustain life, and (c) whose failure to perform when properly used in accordance with instructions for use provided in the labeling, can be reasonably expected to result in a significant injury of the user.

2. A critical component in any component of a life support device or system whose failure to perform can be reasonably expected to cause the failure of the life support device or system, or to affect its safety or effectiveness.