

# HiPerFET™ Power MOSFETs Single Die MOSFET

## IXFE 39N90

$V_{DSS} = 900 \text{ V}$   
 $I_{D25} = 34 \text{ A}$   
 $R_{DS(on)} = 220 \text{ m}\Omega$   
 $t \leq \text{ns}$

N-Channel Enhancement Mode  
Avalanche Rated, High dv/dt, Low  $t_{rr}$

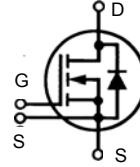

Preliminary Data

Symbol	Test Conditions	Maximum Ratings	
$V_{DSS}$	$T_J = 25^\circ\text{C}$ to $150^\circ\text{C}$	900	V
$V_{DGR}$	$T_J = 25^\circ\text{C}$ to $150^\circ\text{C}$ ; $R_{GS} = 1 \text{ M}\Omega$	900	V
$V_{GS}$	Continuous	$\pm 20$	V
$V_{GSM}$	Transient	$\pm 30$	V
$I_{D25}$	$T_C = 25^\circ\text{C}$ , Chip capability	34	A
$I_{DM}$	$T_C = 25^\circ\text{C}$ , Note 1	154	A
$I_{AR}$	$T_C = 25^\circ\text{C}$	39	A
$E_{AR}$	$T_C = 25^\circ\text{C}$	64	mJ
$E_{AS}$	$T_C = 25^\circ\text{C}$	4	J
dv/dt	$I_S \leq I_{DM}$ , di/dt $\leq 100 \text{ A}/\infty\text{s}$ , $V_{DD} \leq V_{DSS}$ $T_J \leq 150^\circ\text{C}$ , $R_G = 2 \Omega$	5	V/ns
$P_D$	$T_C = 25^\circ\text{C}$	580	W
$T_J$		-40 ... +150	$^\circ\text{C}$
$T_{JM}$		150	$^\circ\text{C}$
$T_{stg}$		-40 ... +150	$^\circ\text{C}$
$V_{ISOL}$	50/60 Hz, RMS $t = 1 \text{ min}$ $I_{ISOL} \leq 1 \text{ mA}$ $t = 1 \text{ s}$	2500 3000	V~ V~
$M_d$	Mounting torque Terminal connection torque	1.5/13 1.5/13	Nm/lb.in. Nm/lb.in.

ISOPLUS 227™ (IXFE)

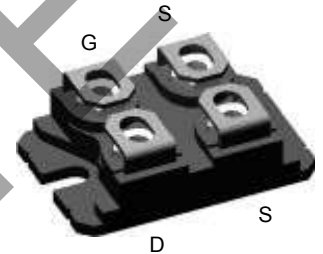

G = Gate  
S = Source  
D = Drain

Either Source terminal at miniBLOC can be used as Main or Kelvin Source

### Features

- Conforms to SOT-227B outline
- Low  $R_{DS(on)}$  HDMOS™ process
- Rugged polysilicon gate cell structure
- Unclamped Inductive Switching (UIS) rated
- Low package inductance
- Fast intrinsic Rectifier

### Applications

- DC-DC converters
- Battery chargers
- Switched-mode and resonant-mode power supplies
- DC choppers
- Temperature and lighting controls

### Advantages

- Low cost
- Easy to mount
- Space savings
- High power density

Symbol	Test Conditions	Characteristic Values ( $T_J = 25^\circ\text{C}$ , unless otherwise specified)		
		min.	typ.	max.
$V_{DSS}$	$V_{GS} = 0 \text{ V}$ , $I_D = 3 \text{ mA}$	900		V
$V_{GH(th)}$	$V_{DS} = V_{GS}$ , $I_D = 8 \text{ mA}$	2.5		V
$I_{GSS}$	$V_{GS} = \pm 20 \text{ V}_{DC}$ , $V_{DS} = 0$			$\pm 200 \text{ nA}$
$I_{DSS}$	$V_{DS} = V_{DSS}$ , $T_J = 25^\circ\text{C}$ $V_{GS} = 0 \text{ V}$ , $T_J = 125^\circ\text{C}$			100 $\infty\text{A}$ 2 mA
$R_{DS(on)}$	$V_{GS} = 10 \text{ V}$ , $I_D = I_T$ Notes 2, 3			220 m $\Omega$

Symbol	Test Conditions	Characteristic Values ( $T_j = 25^\circ\text{C}$ , unless otherwise specified)		
		min.	typ.	max.
$g_{fs}$	$V_{DS} = 15\text{ V}; I_D = I_T$ , Note 2	30	45	S
$C_{iss}$	$V_{GS} = 0\text{ V}, V_{DS} = 25\text{ V}, f = 1\text{ MHz}$		13400	pF
$C_{oss}$			1230	pF
$C_{rss}$			320	pF
$t_{d(on)}$	$V_{GS} = 10\text{ V}, V_{DS} = 0.5 \cdot V_{DSS}, I_D = I_T$ $R_G = 1\ \Omega$ (External),		45	ns
$t_r$			68	ns
$t_{d(off)}$			125	ns
$t_f$			30	ns
$Q_{g(on)}$	$V_{GS} = 10\text{ V}, V_{DS} = 0.5 \cdot V_{DSS}, I_D = I_T$		375	nC
$Q_{gs}$			75	nC
$Q_{gd}$			190	nC
$R_{thJC}$			0.22	K/W
$R_{thCK}$			0.07	K/W

### ISOPLUS-227 B

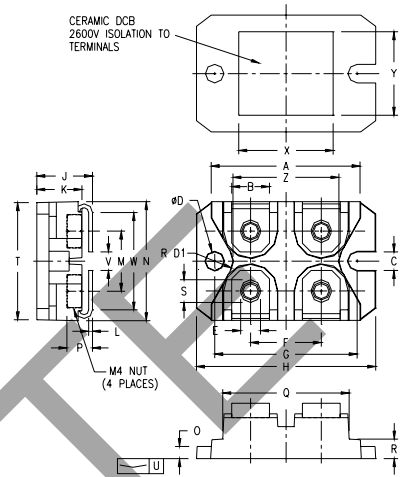

SYM	INCHES		MILLIMETERS	
	MIN	MAX	MIN	MAX
A	1.240	1.270	31.50	32.26
B	.310	.330	7.87	8.38
C	.155	.165	3.94	4.19
D	.155	.165	3.94	4.19
D1	.150	.157	3.81	3.98
E	.160	.168	4.06	4.27
F	.587	.595	14.91	15.11
G	1.186	1.193	30.12	30.30
H	1.489	1.505	37.80	38.23
J	.465	.481	11.81	12.22
K	.370	.380	9.40	9.65
L	.030	.033	0.76	0.84
M	.496	.506	12.60	12.85
N	.990	1.001	25.15	25.42
O	.100	.105	2.54	2.67
P	.195	.235	4.95	5.97
Q	1.045	1.059	26.54	26.90
R	.160	.170	4.06	4.32
S	.186	.191	4.72	4.85
T	.968	.987	24.59	25.07
U	-.001	.002	-0.03	0.05
V	.130	.160	3.30	4.06
W	.780	.830	19.81	21.08
X	.770	.810	19.56	20.57
Y	.680	.720	17.27	18.29
Z	.885	.892	22.48	22.66

### Source-Drain Diode

Symbol	Test Conditions	Characteristic Values ( $T_j = 25^\circ\text{C}$ , unless otherwise specified)		
		min.	typ.	max.
$I_S$	$V_{GS} = 0\text{ V}$			39 A
$I_{SM}$	Repetitive; Note 1			154 A
$V_{SD}$	$I_F = I_S, V_{GS} = 0\text{ V}$ , Note 2			1.3 V
$t_{rr}$	$I_F = 25\text{ A}, -di/dt = 100\text{ A}/\mu\text{s}, V_R = 100\text{ V}$			250 ns
$Q_{RM}$			2	$\infty$ C
$I_{RM}$			9	A

Please see IXFN39N90 data sheet for characteristic curves.

- Notes:
1. Pulse width limited by  $T_{JM}$ .
  2. Pulse test,  $t \leq 300\text{ ms}$ , duty cycle  $d \leq 2\%$ .
  3.  $I_T$  Test current:  $I_T = 19.5\text{ A}$

IXYS reserves the right to change limits, test conditions, and dimensions.