



96 X 96mm

**Features :**

- True RMS measurement of voltage & current
- Frequency measurement
- 1Ø & 3Ø measurement available with LED display
- Programmable CT & PT ratio
- CE & RoHS certified

Certifications :  

**Display Specifications**

Display	7 segment LED Display
Digits	3
Digit Height	0.58" (14.7mm)
Resolution	Voltage & Current : Auto resolution (Depending upon CT & PT ratio) RPM: 0.1 Run Hour : 0.1 hr

**Operational characteristics**

Electrical Connection	3Ø- 3 wire, 3Ø- 4 wire
Input type	AC
Input Voltage Range	11 to 300V AC (L-N), 19 to 519V AC (L-L)
Input Current Range	30mA – 6AAC
Continuous Max. Input Current :	120% of rated current
Accuracy	Voltage : ±0.5% of F.S. ±2 Digits Current : ±1% of F.S. ±2 Digits Frequency : ±0.1 Hz ±1 Digits Run Hour : ±1%, RPM : ±0.5% RPM : ±0.5% Voltage : ±0.5% of F.S. ±2 Digits Current : ±1% of F.S. ±2 Digits Frequency : ±0.1 Hz ±1 Digits Run Hour : ±1% RPM : ±0.5% Voltage : ±0.5% of F.S. ±2 Digits Current : ±1% of F.S. ±2 Digits Frequency : ±0.1 Hz ±1 Digits Run Hour : ±1% RPM : ±0.5%
Frequency Range	50 - 60Hz
RPM Range	1350 to 1950
Run Hour	0 to 99999.9 hr
Measurement	3Ø Voltage (L-N, L-L, Avg.) 3Ø Current (I1, I2, I3, Avg.) Frequency RPM Run Hour 3Ø Voltage (L-N, L-L, Avg.) 3 Ø Current (I1, I2, I3, Avg.) Frequency RPM Run Hour 3Ø Voltage (L-N, L-L, Avg.) 3Ø Current (I1, I2, I3, Avg.) Frequency RPM Run Hour

**Electrical specification**

Installation category	III
High Voltage Test	2kV AC, 50Hz
IP protection	IP51 Front Only
Sampling Rate	3 samples / second
Dielectric withstand Voltage	2kV AC between auxiliary supply & measuring input
Rated Impulse withstand Voltage	3.5kV (1.2/50µS)

**Auxiliary Supply Specifications**

Auxiliary Supply	AC: 230V AC ±20% , (50 / 60Hz) 110V AC ±20% , (60Hz) AC: 230V AC ±20% , (50 / 60Hz) 110V AC ±20% , (60Hz)
Supply Frequency	50 / 60Hz
Input Burden	0.5 VA @ 5A AC
Power Consumption	5VA max @ 240V AC

**Settable Parameters**

CT Primary	5A to 10.0kA (Programmable for any value)
CT Secondary	5A Fixed
CT Primary	100 to 500kV (Programmable for any value)
CT Secondary	100 to 500V (Programmable for any value)
No. of poles	0 to 98

**Formula**

Run Hour calculation	12.34 hr = 12 hr + 0.34 hr 0.34 hr × 60 min = 20.40 min 20.40 min = 20 min + 0.40 min 0.40 min × 60 sec = 24 sec 12:20:24 (HH:MM:SS)
Number of Poles to RPM calculation	RPM = 60 x f / Pair of Poles f= Supply frequency RPM = 60 x f / Pair of Poles f= Supply frequency

**Environmental characteristics:**

Operating Temperature	-10°C to +55°C (14°F to 131°F)
Storage Temperature	-20°C to +75°C (-4°F to 167°F)
Humidity (non-condensing)	Up to 85% RH
Pollution degree	2
Altitude	Upto 2000 meters
Measurement Category	CAT III

**Mechanical characteristic:**

Mounting	Panel mount
Bezel size	96mm x 96 mm
Overall depth	50 mm
Weight	367 gms
Torque at terminals	0.68N-m to 0.79 N-m
Wire Gauge at terminals	20 to 14AWG;75°C
Mounting position	Vertical

**Dimensions**

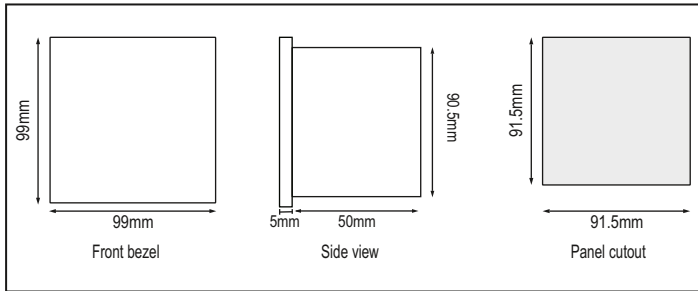

**Terminal Connections**

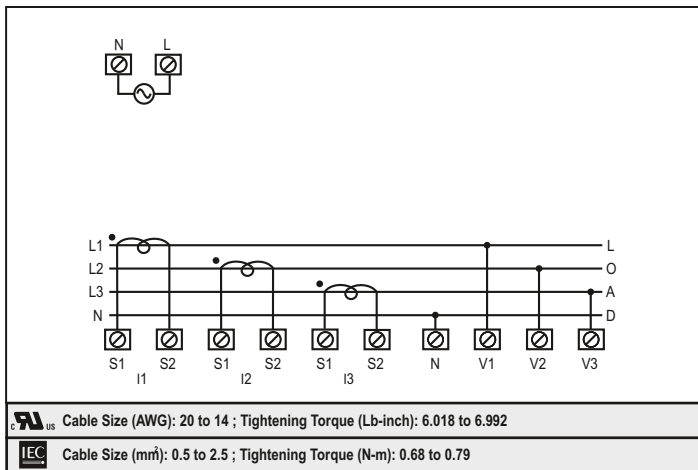

**Compliance**

Applicable EMI / EMC Standards		
Product Standard : IEC 61326-1		
Category		Standards Compliance
ESD Immunity	IEC 61000-4-2	Level IV (Air discharge : 15kV), (Contact Discharge : -8kV)
Surge Immunity	IEC 61000-4-5	+/- 2kV common mode, (Line to ground) +/- 1kV differential mode, (Line to Line)
Radiated Susceptibility	IEC 61000-4-3	Level III, 80 to 1000MHz (10V/m) Level II, 1.4GHz to 2GHz (3V/m) Level I, 2GHz to 2.7GHz (1V/m)
Conducted Susceptibility	IEC 61000-4-6	Level II (3V/m)
Voltage Dips and Interruptions	IEC 61000-4-11	<b>Dips</b> : 0% residual voltage / 1 cycle (Criteria B), 40% residual voltage / 10 cycles 50Hz / 12 cycles 60Hz (Criteria C) 70% residual voltage / 25 cycles 50Hz / 30 cycles 60Hz (Criteria C) <b>Interruptions</b> : 0% residual voltage / 250 cycles 50Hz / 300 cycles 60Hz (Criteria C)
Conducted Emission	CISPR-11	
Radiated Emission	CISPR-11	
Electrical Fast Transient	IEC 61000-4-4	Level III (2kV)

**Ordering Information**

Product Code	Supply Voltage	Certification
VAF39A-230V AC-CE	230V AC	-
VAF39A-230V AC	230V AC	CE
VAF39A-110V	100V AC	CE c(UL)US LISTED
VAF39A-110V CU	100V AC	CE c(UL)US LISTED