



BU Series (1c)

Surface Mount Reed Relays

Features

- Available in Axial, Gull wing and J Lead configurations.
- Tape and Reel packaging available.
- High reliability, hermetically sealed contacts for long life.
- High Insulation Resistance - $10^9\Omega$ minimum.
- Coaxial shield for 50Ω impedance. Excellent for RF and Fast.
- Rise Time Pulse switching (up to 6 GHz).
- External Magnetic Shield.



Order Code

BU-1C XX X
a b c

a : Contact Form : 1C=1FormC

b : Nominal Coil Voltage : 03=3.3VDC, 05=5VDC

c : Nil=Standard Type, J=SMD J Model

Coil Data-Standard Type (at 20°C)

Part Number	Nominal Voltage DC $\pm 10\%$ [V]	Coil Resistance $\pm 10\%$ [ohm]	Max. Coil Voltage (VDC)	Must Release Voltage MIN. [V] at 20°C	Must Operate Voltage MAX. [V] at 20°C
BU-1C03	3.3	70	4	0.4	2.5
BU-1C05	5	110	6	0.4	3.8

Contact Rating

Contact Form	1 Form C
Contact Rating MAX DC / Peak AC resistance	3W
Switching Voltage MAX DC / Peak AC resistance	30VDC
Max.Switching Current MAX DC / Peak AC resistance	0.1A
Max.Carry Current MAX DC / Peak AC resistance	0.2A



Specification

Contact Form	1 Form C	
Static Contact Resistance (Max.init)	200mΩ	
Breakdown Voltage	Between contacts	200VDC / peak AC
	Contacts to shield	1000VDC / peak AC
	Contacts / shield to coil	1000VDC / peak AC
Insulation Resistance	1x10 ⁹ Ω	
Capacitance-Typical	Open Contact 1.0pF	
Operate Time-including bounce-Typical	0.3mS	
Release Time	0.3mS	
Vibration	20G's to 2000HZ	
shock	50G's	
Operating Temp	-20°C ~+85°C	
Storage Temp	-35°C ~+100°C	
Life Expectancy	Signal Level 1.0V, 10mA, 1x10 ⁸ Ops.	

Dimensions (Unit : mm)

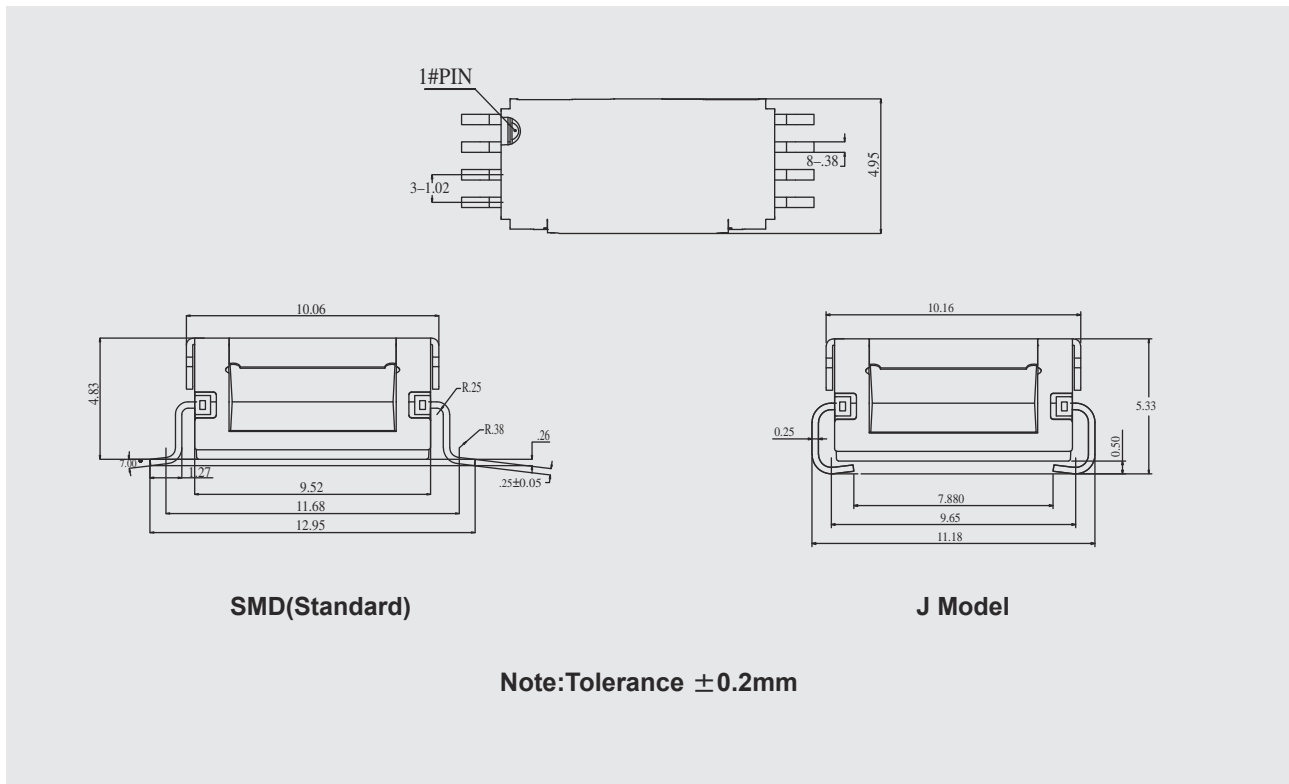

Wiring Diagrams (Top View)

