

THIS DRAWING IS UNPUBLISHED.

RELEASED FOR PUBLICATION

ALL RIGHTS RESERVED.

© COPYRIGHT - By -

REVISIONS

P	LTR	DESCRIPTION	DATE	DWN	APVD
	AC1	REVISED PER ECO-16-001584	04FEB2016	NK	DR
	AC2	REVISED PER ECO-17-007400	18DEC2017	RS	DR

AMP WIRE RANGE	E13288 Listed	LR7189 Certified
16-14 AWG SOLID OR STRANDED	16-14 AWG SOLID OR STRANDED	16-14 AWG SOLID OR STRANDED

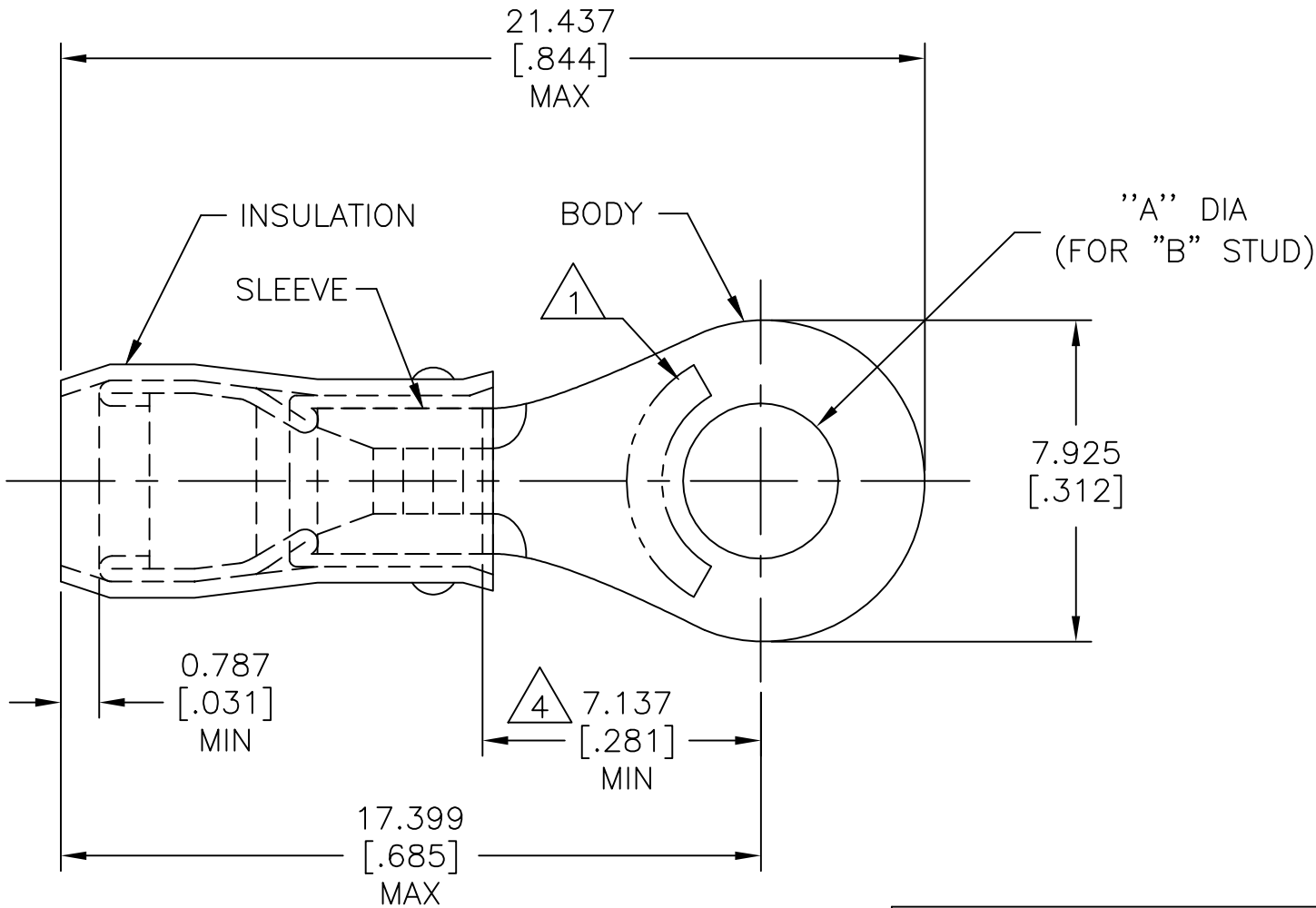

- △ 1 STAMP AMP 16-14* APPROX AS SHOWN.
- 2 WIRE INSULATION : $\phi 2.669-3.810[\phi .105-.150]$.
- 3 BODY MATERIAL THK: $0.787\pm 0.051[.031\pm .002]$.
- △ 4 APPLIES FROM EDGE OF METAL WIRE BARREL TO CENTER OF STUD HOLE

-	[10]	$5.004\pm 0.076[.197\pm .003]$	100	LOOSE PIECE, BOX	5-51864-1
-	M4[8]	$4.343\pm 0.076[.171\pm .003]$	100	LOOSE PIECE, BOX	4-51864-1
-	M3.5[6]	$3.683\pm 0.076[.145\pm .003]$	100	LOOSE PIECE, BOX	3-51864-1
MS25036-153 CLASS 2	M4[8]	$4.343\pm 0.076[.171\pm .003]$	5000	ON TAPE, REEL	51864-5
MS25036-108 CLASS 2	[10]	$5.004\pm 0.076[.197\pm .003]$	5000	ON TAPE, REEL	51864-4
MS25036-107 CLASS 2	M3.5[6]	$3.683\pm 0.076[.145\pm .003]$	5000	ON TAPE, REEL	51864-3
MS25036-108 CLASS 1 & 2	[10]	$5.004\pm 0.076[.197\pm .003]$	1000	LOOSE PIECE	51864-2
MS25036-153 CLASS 1 & 2	M4[8]	$4.343\pm 0.076[.171\pm .003]$	1000	LOOSE PIECE	51864-1
MS25036-107 CLASS 1 & 2	M3.5[6]	$3.683\pm 0.076[.145\pm .003]$	1000	LOOSE PIECE	51864
MILITARY P/N AND CLASS	"B"	DIM "A"	QUANTITY	PACKAGE TYPE	PART NO

AMP INCORPORATED CUSTOMER SERVICE SYSTEMS		MAX RECOMMENDED OPERATING TEMPERATURE: 105°C[221°F] MAX	THIS DRAWING IS A CONTROLLED DOCUMENT.		DWN JR RUTH 27OCT99	TE Connectivity		
FOR ADDITIONAL PRODUCT INFORMATION OR COPIES OF DRAWINGS AND TECHNICAL DOCUMENTS	PRODUCT INFORMATION CENTER 1-800-522-6752	VOLTAGE RATING: 300 V MAX	DIMENSIONS: mm [INCHES]	TOLERANCES UNLESS OTHERWISE SPECIFIED:	CHK RE HERSEY 27OCT99		NAME TERMINAL, RING TONGUE, PIDG, TM WIRE SIZE, 16-14 AWG	
FOR APPLICATION TOOLING INFORMATION	TOOLING ASSISTANCE CENTER 1-800-722-1111	CIRCULAR MIL AREA: 1.04-2.62mm ² [2050-5180] CIR MILS SOLID OR STRANDED		0 PLC ± - 1 PLC ± - 2 PLC ± - 3 PLC ± 0.127[.005] 4 PLC ± - ANGLES ± -	APVD C PRESNELL 27OCT99	APPLICATION SPEC 114-2157		
FOR ORDER ENTRY	1-800-526-5142		MATERIAL BODY & SLEEVE: COPPER PER ASTM B-152 INSULATION: NYLON	FINISH BODY & SLEEVE: TIN PLATE PER ASTM B545 INSULATION: COLOR-BLUE	PRODUCT SPEC UL 486 A-B	WEIGHT -		
			CUSTOMER DRAWING		SIZE A3	CAGE CODE 00779	DRAWING NO C=51864	RESTRICTED TO -
					SCALE NTS	SHEET 1 of 2	REV AC2	

THIS DRAWING IS UNPUBLISHED.

RELEASED FOR PUBLICATION

ALL RIGHTS RESERVED.

© COPYRIGHT - By -

REVISIONS

P	LTR	DESCRIPTION	DATE	DWN	APVD
-	-	SEE SHEET 1	-	-	-

3 STRIPES EQUALLY SPACED FOR COLOR CODE: SEE TABLE

AMP WIRE RANGE

SEE TABLE STRANDED

BODY

"A" DIA (FOR "B" STUD)

INSULATION

SLEEVE



7.925 [.312]



1 STAMP AMP APPROX AS SHOWN SEE TABLE BELOW.

2 WIRE INSULATION : $\phi 1.600-3.302[\phi 0.063-.130]$ FOR 16 AWG, $\phi 1.981-3.302[\phi 0.078-.130]$ FOR 14 AWG.

3 BODY MATERIAL THK: $0.787 \pm 0.051[.031 \pm .002]$.



4 APPLIES FROM EDGE OF METAL WIRE BARREL TO CENTER OF STUD HOLE

0.787 [.031] MIN

7.137 [.281] MIN

18.974 [.747] MAX

23.012 [.906] MAX

-	BLUE	16*	16	M3.5[6]	$3.683 \pm 0.076[.145 \pm .003]$	100	LOOSE PIECE, BOX	6-51864-1
M7928/1-50 CLASS 2	GREEN	14*	14	M4[8]	$4.343 \pm 0.076[.171 \pm .003]$	5000	ON TAPE, REEL	1-51864-7
M7928/1-51 CLASS 2	GREEN	14*	14	[10]	$5.004 \pm 0.076[.197 \pm .003]$	5000	ON TAPE, REEL	1-51864-5
M7928/1-42 CLASS 2	BLUE	16*	16	[10]	$5.004 \pm 0.076[.197 \pm .003]$	5000	ON TAPE, REEL	1-51864-3
M7928/1-50 CLASS 1 & 2	GREEN	14*	14	M4[8]	$4.343 \pm 0.076[.171 \pm .003]$	1000	LOOSE PIECE	1-51864-1
M7928/1-41 CLASS 1 & 2	BLUE	16*	16	M4[8]	$4.343 \pm 0.076[.171 \pm .003]$	1000	LOOSE PIECE	1-51864-0
M7928/1-51 CLASS 1 & 2	GREEN	14*	14	[10]	$5.004 \pm 0.076[.197 \pm .003]$	1000	LOOSE PIECE	51864-9
M7928/1-49 CLASS 1 & 2	GREEN	14*	14	M3.5[6]	$3.683 \pm 0.076[.145 \pm .003]$	1000	LOOSE PIECE	51864-8
M7928/1-42 CLASS 1 & 2	BLUE	16*	16	[10]	$5.004 \pm 0.076[.197 \pm .003]$	1000	LOOSE PIECE	51864-7
M7928/1-40 CLASS 1 & 2	BLUE	16*	16	M3.5[6]	$3.683 \pm 0.076[.145 \pm .003]$	1000	LOOSE PIECE	51864-6
MILITARY P/N AND CLASS	STRIPE COLOR		WIRE SIZE	"B"	DIM "A"	QUANTITY	PACKAGE TYPE	PART NO

AMP INCORPORATED CUSTOMER SERVICE SYSTEMS

MAX RECOMMENDED OPERATING TEMPERATURE: 105°C[221°F] MAX

THIS DRAWING IS A CONTROLLED DOCUMENT.

DWN JR RUTH 27OCT99

CHK RE HERSEY 27OCT99

APVD C PRESNELL 27OCT99

PRODUCT SPEC

APPLICATION SPEC

114-2157

WEIGHT -

CUSTOMER DRAWING

TE Connectivity

NAME: TERMINAL, RING TONGUE, I.R., PIDG™, WIRE SIZE, 16 & 14 AWG

SIZE: A3 CAGE CODE: 00779 DRAWING NO: 51864 RESTRICTED TO: -

SCALE: NTS SHEET: 2 OF 2 REV: AC2

FOR ADDITIONAL PRODUCT INFORMATION OR COPIES OF DRAWINGS AND TECHNICAL DOCUMENTS

PRODUCT INFORMATION CENTER 1-800-522-6752

VOLTAGE RATING: 300 V MAX

WIRE RANGE: 16 14 CIRC MIL AREA: 1.42mm² [2800] 2.15mm² [4234] STRANDED

DIMENSIONS: mm [INCHES]

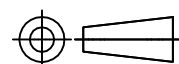

TOLERANCES UNLESS OTHERWISE SPECIFIED:

0 PLC ± - 1 PLC ± - 2 PLC ± - 3 PLC ± 0.127[.005] 4 PLC ± - ANGLES ± -

MATERIAL BODY & SLEEVE: COPPER PER ASTM B-152 INSULATION: NYLON

FINISH BODY & SLEEVE: TIN PLATE PER ASTM B545 INSULATION: COLOR-BLUE

FOR ORDER ENTRY

1-800-526-5142

FOR APPLICATION TOOLING INFORMATION

TOOLING ASSISTANCE CENTER 1-800-722-1111