

LOC		DIST		REVISIONS			
GP	00	P	LTR	DESCRIPTION	DATE	DMN	APVD
S1				REVISED PER ECO-11-004835	11MAR11	RK	HMR

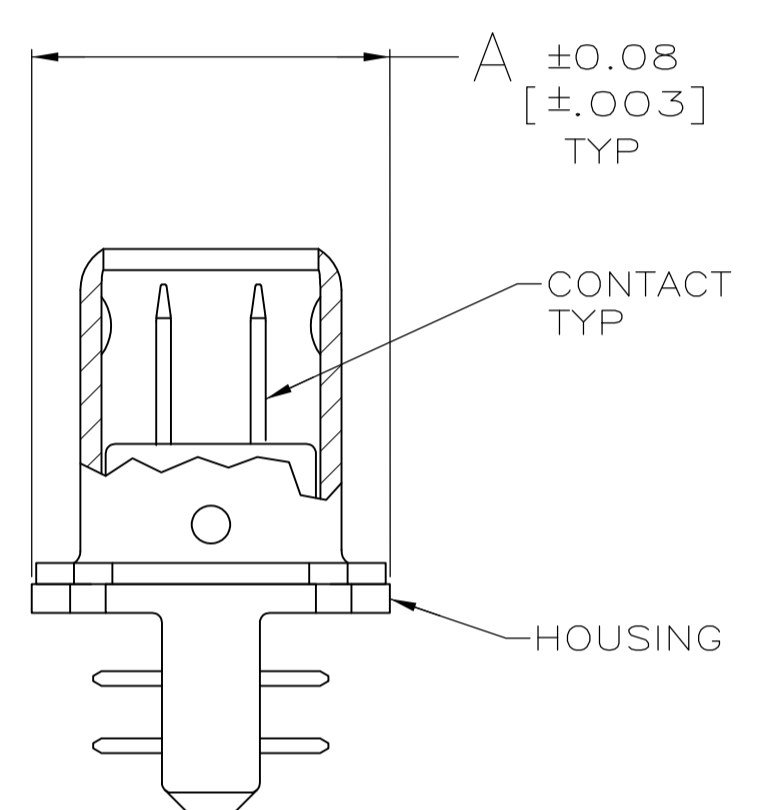

- 1 CONTACTS: PHOSPHOR BRONZE.  
SHELL: CARBON STEEL  
HOUSING : POLYESTER, BLACK, UL 94V-0 RATED.  
TERMINATING COVERS: POLYESTER, UL 94V-0 RATED, COLOR: SEE TABLE
- 2 PLATED WITH EITHER 0.76µm [.000030] MIN GOLD PLATE OR GOLD FLASH OVER PALLADIUM NICKEL PLATE, 0.76µm [.000030] MIN TOTAL FOR A LENGTH OF 3.35 [.132] MIN FROM MATING END. 1.52µm [.000060] MIN TIN-LEAD IN TERMINATION AREA, ALL OVER 1.27µm [.000050] MIN NICKEL.
- 3 0.25µm [.000010] MIN TIN-NICKEL OVER 3.81µm [.000150] MIN NICKEL OVER 2.54µm [.000100] MIN COPPER.
- 4 RECOMMENDED WIRE: 28 AWG OR 30 AWG, SOLID OR 7 STRAND, PVC INSULATION, REFER TO TABLE BELOW FOR INSULATION DIA.
- 5. COVERS PACKAGED SEPARATE FROM CONNECTORS IN SAME SHIPPING CONTAINER.
- 6 GOLD FLASH FOR A LENGTH OF 3.35 [.132] MIN FROM MATING END, 1.27µm [.000050] MIN TIN-LEAD IN TERMINATION AREA, BOTH OVER 1.27µm [.000050] MIN NICKEL.
- 7 OBSOLETE PART NUMBER.
- 8 PLATED WITH EITHER 0.76µm [.000030] MIN GOLD PLATE OR GOLD FLASH OVER PALLADIUM NICKEL PLATE, 0.76µm [.000030] MIN TOTAL FOR A LENGTH OF 3.35 [.132] MIN FROM MATING END. 3.00µm [.000118] MIN TIN IN TERMINATION AREA, ALL OVER 1.27µm [.000050] MIN NICKEL.
- 9 SUPERSEDED BY 750913-4.
- 10 SUPERSEDED BY 1-5750913-5.
- 11 SUPERSEDED BY 5750913-5.
- 12 SUPERSEDED BY 1-5750913-7.
- 13 SUPERSEDED BY 1-5750913-9.
- 14 SUPERSEDED BY 5750913-7.
- 15 SUPERSEDED BY 1-5750913-2.

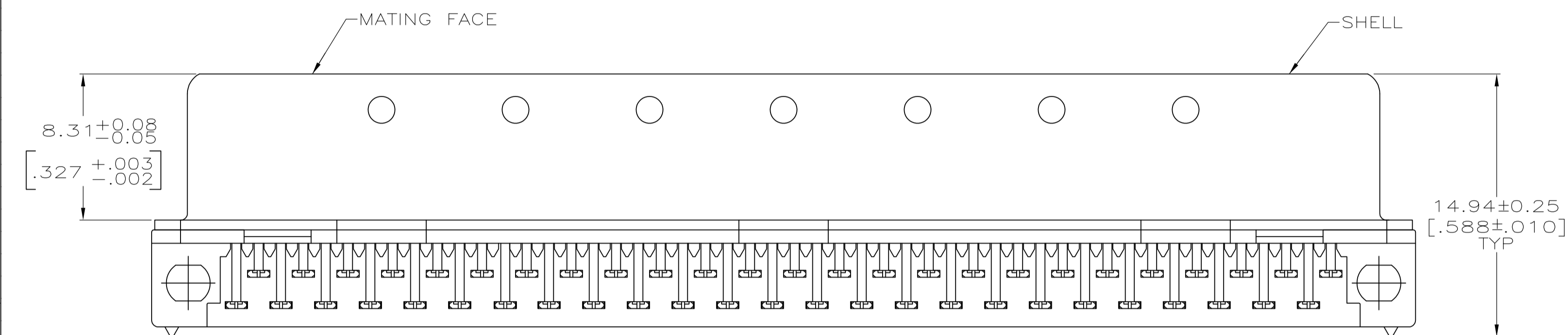
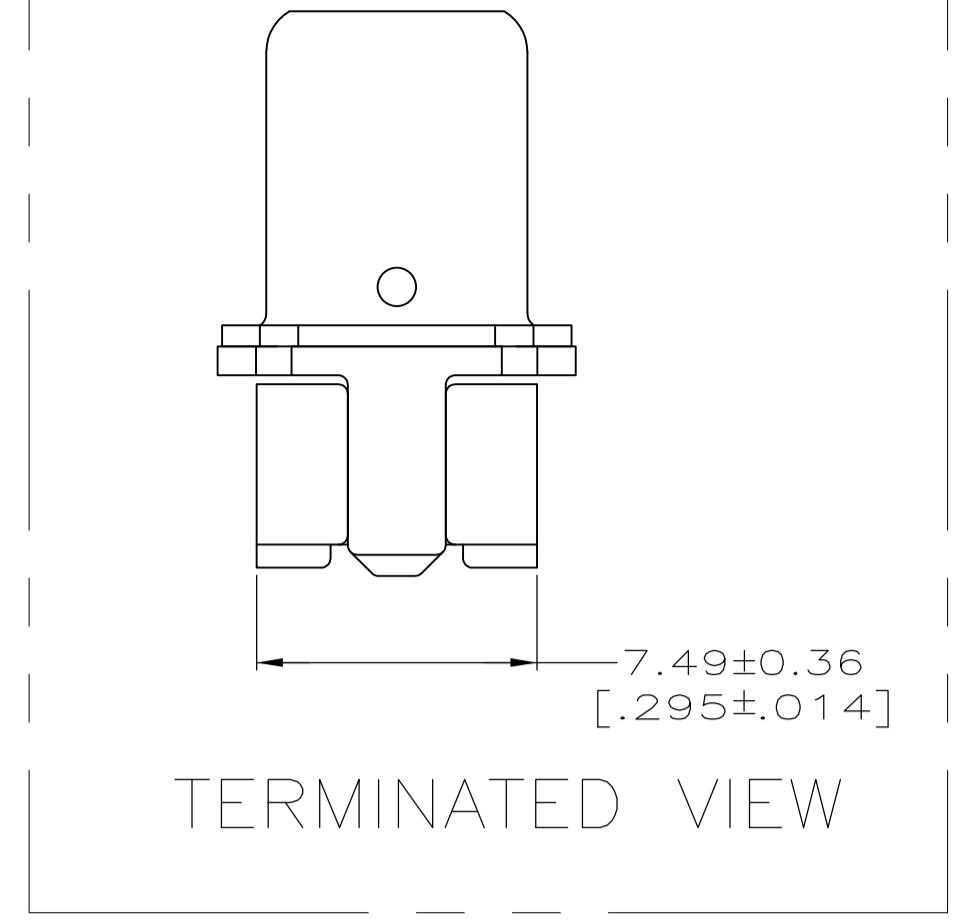
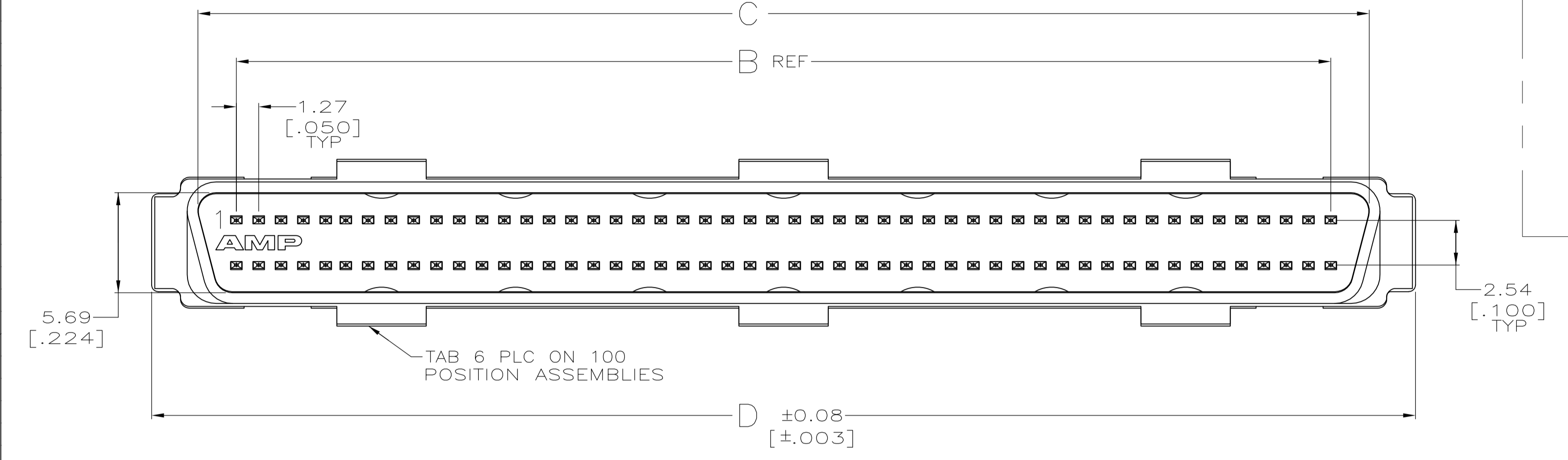
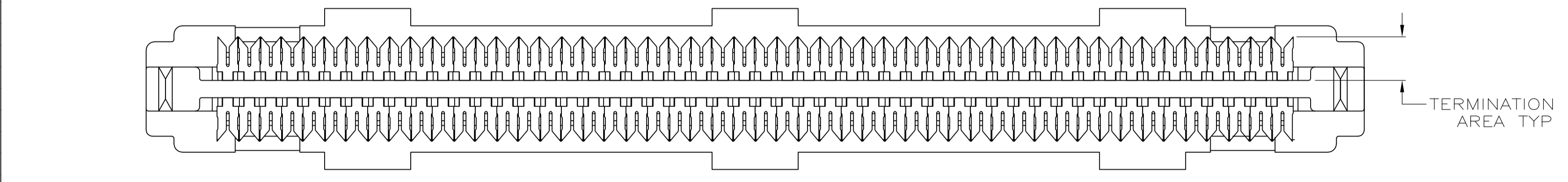

6	GRAY	0.74-0.79 [.029-.031]	40.11 [1.579]	34.85 [1.372]	30.48 [1.200]	7.44 [.293]	50	3-750913-5
6	BLACK	0.81-0.91 [.032-.036]	40.11 [1.579]	34.85 [1.372]	30.48 [1.200]	7.44 [.293]	50	2-750913-5
8	GRAY	0.74-0.79 [.029-.031]	71.86 [2.829]	66.60 [2.622]	62.23 [2.450]	9.47 [.373]	100	2-750913-2
8	GRAY	0.74-0.79 [.029-.031]	51.54 [2.029]	46.28 [1.822]	41.91 [1.650]	7.44 [.293]	68	2-750913-1
8	BLACK	0.81-0.91 [.032-.036]	40.11 [1.579]	34.85 [1.372]	30.48 [1.200]	7.44 [.293]	50	2-750913-0
2	GRAY	0.74-0.79 [.029-.031]	71.86 [2.829]	66.60 [2.622]	62.23 [2.450]	9.47 [.373]	100	1-750913-9
2	GRAY	0.74-0.79 [.029-.031]	51.54 [2.029]	46.28 [1.822]	41.91 [1.650]	7.44 [.293]	68	1-750913-7
2	GRAY	0.74-0.79 [.029-.031]	40.11 [1.579]	34.85 [1.372]	30.48 [1.200]	7.44 [.293]	50	1-750913-5
2	GRAY	0.74-0.79 [.029-.031]	33.76 [1.329]	28.50 [1.122]	24.13 [.950]	7.44 [.293]	40	1-750913-4
2	GRAY	0.74-0.79 [.029-.031]	24.87 [.979]	19.61 [.772]	15.24 [.600]	7.44 [.293]	26	1-750913-2
2	BLACK	0.81-0.91 [.032-.036]	71.86 [2.829]	66.60 [2.622]	62.23 [2.450]	9.47 [.373]	100	750913-9
2	BLACK	0.81-0.91 [.032-.036]	51.54 [2.029]	46.28 [1.822]	41.91 [1.650]	7.44 [.293]	68	750913-7
2	BLACK	0.81-0.91 [.032-.036]	40.11 [1.579]	34.85 [1.372]	30.48 [1.200]	7.44 [.293]	50	750913-5
2	BLACK	0.81-0.91 [.032-.036]	33.76 [1.329]	28.50 [1.122]	24.13 [.950]	7.44 [.293]	40	750913-4
2	BLACK	0.81-0.91 [.032-.036]	24.87 [.979]	19.61 [.772]	15.24 [.600]	7.44 [.293]	26	750913-2
CONTACT FINISH	TERMINATING COVERS COLOR	INSULATION OUTER DIAMETER	D	C	B	A	NO OF POSN	PART NUMBER

THIS DRAWING IS A CONTROLLED DOCUMENT.

DIMENSIONS: mm [INCHES]  
 TOLERANCES UNLESS OTHERWISE SPECIFIED:  
 0 PLC ± -  
 1 PLC ± ±  
 2 PLC ± ± 0.13[.005]  
 3 PLC ± ±  
 4 PLC ± ±  
 ANGLES ± ±

MATERIAL: 1  
 SHELL: 1  
 CONTACTS: SEE TABLE

THIS DRAWING IS A CONTROLLED DOCUMENT.  
 DWG: J. McCLINTON 8-13-91  
 CHK: R. STONE 8-19-91  
 APVD: -  
 NAME: -  
 PRODUCT SPEC: -  
 APPLICATION SPEC: 108-1228  
 SIZE: 114-40029  
 WEIGHT: -  
 CUSTOMER DRAWING

STE TE Connectivity  
 PLUG KIT, UNASSEMBLED,  
 DISCRETE WIRE TERMINATING COVER,  
 .050 SERIES, AMPLITE

SCALE: 5:1 SHEET 1 OF 1 REV: S1