

THIS DRAWING IS UNPUBLISHED. RELEASED FOR PUBLICATION
 © COPYRIGHT - By - ALL RIGHTS RESERVED.

LOC		DIST		REVISIONS			
P	LTR	DESCRIPTION		DATE	DWN	APVD	
AD	00	A2	REVISED PER ECO-11-004917		11MAR11	RK	HMR

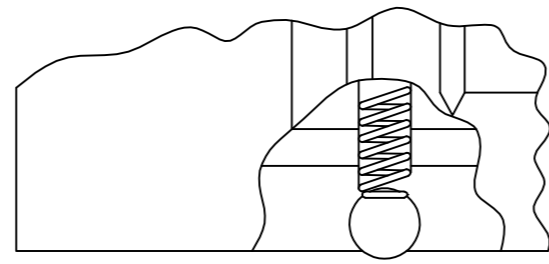
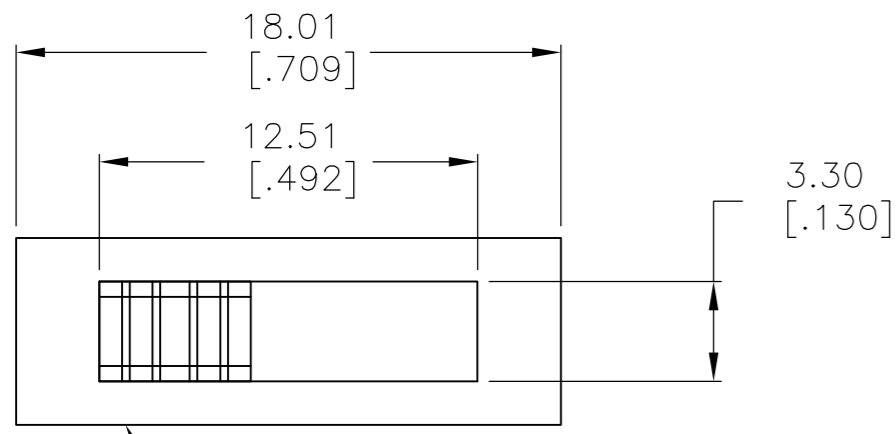

DETAIL A

SPECIFICATIONS:
 MAKE-BEFORE-BREAK

MATERIALS:
 FRAME: STEEL, ZINC PLATE
 ACTUATOR: POM UL94HB, BLACK
 FIXED CONTACT/TERMINAL: COPPER ALLOY, SILVER OVER NICKEL PLATE
 MOVING CONTACT: COPPER ALLOY, SILVER CLAD
 COIL SPRING: TEMPERED STEEL WIRE
 BALL- TEMPERED CARBON STEEL
 TERMINAL BOARD: PHENOLIC, UL94HB
 TERMINAL SEAL: EPOXY

ELECTRICAL:
 CONTACT RATING: 250 MILLIAMPS@125V AC
 CONTACT RESISTANCE: 30 MILLIOHMS MAX (INITIAL), 60 MILLIOHMS AFTER TEST
 INSULATION RESISTANCE: 500 MEGOHMS MIN AT 500V DC
 DIELECTRIC STRENGTH: 500 VAC RMS AT SEA LEVEL
 LIFE EXPECTANCY: 10,000 CYCLES MIN. NO LOAD

MECHANICAL:
 +150
 ACTUATION FORCE: 250-100 GRAMS
 TRAVEL: 2.49 [.098]

ENVIRONMENTAL:
 OPERATING TEMPERATURE: -10° C TO +60° C
 STORAGE TEMPERATURE: -10° C TO +60° C
 RESISTANCE TO SOLDER HEAT: 260° C FOR 10 SEC PER 109-202, COND. B
 SOLDERABILITY: PER EIA-364-56A, PROCEDURE 3, COND. B

- NOTES:
- ALL MATERIALS AND FINISHES SHALL COMPLY WITH EU DIRECTIVE 2002/95/EC OF 27JAN2003 (ROHS)
 - ALL PERFORMANCE SPECIFICATIONS WERE TESTED IN ACCORDANCE WITH JIS-C-5441 UNLESS OTHERWISE STATED.

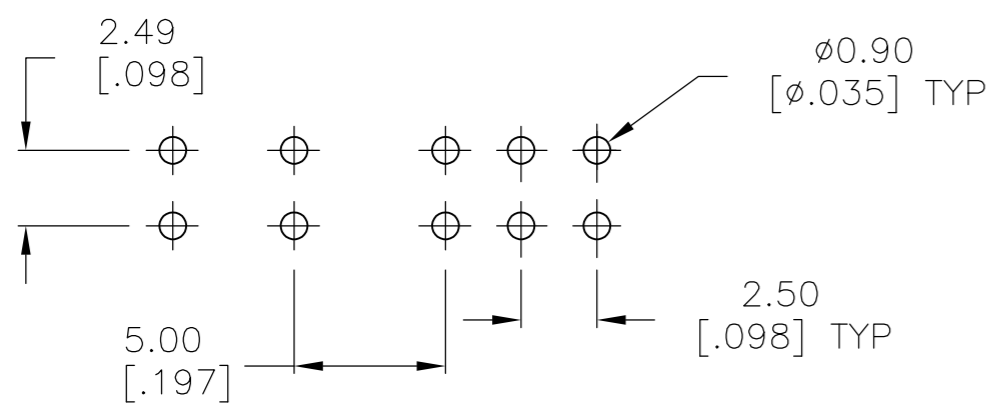
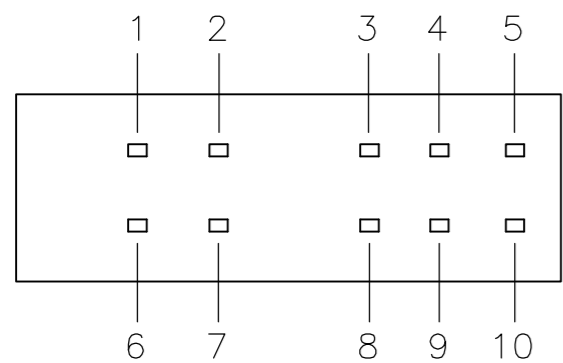
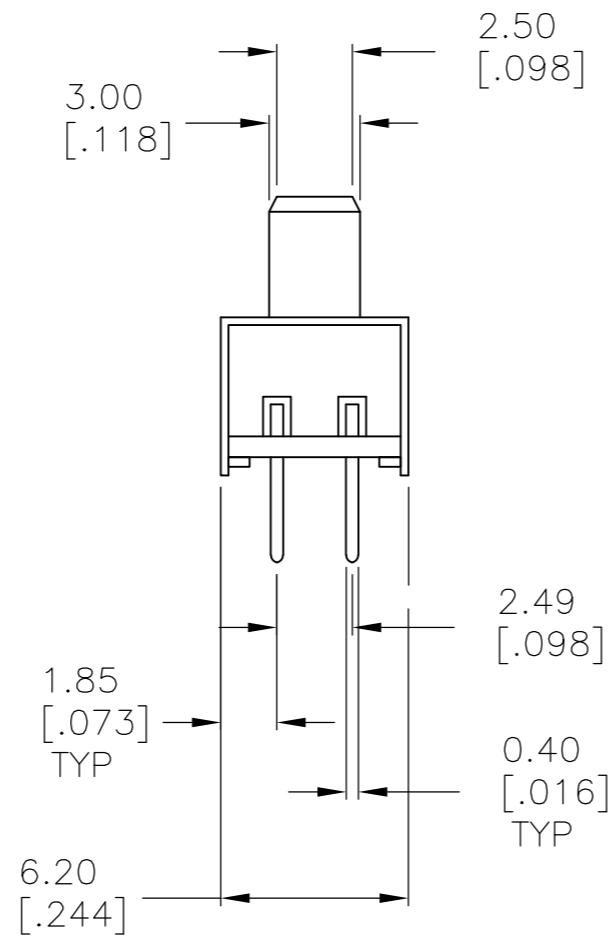
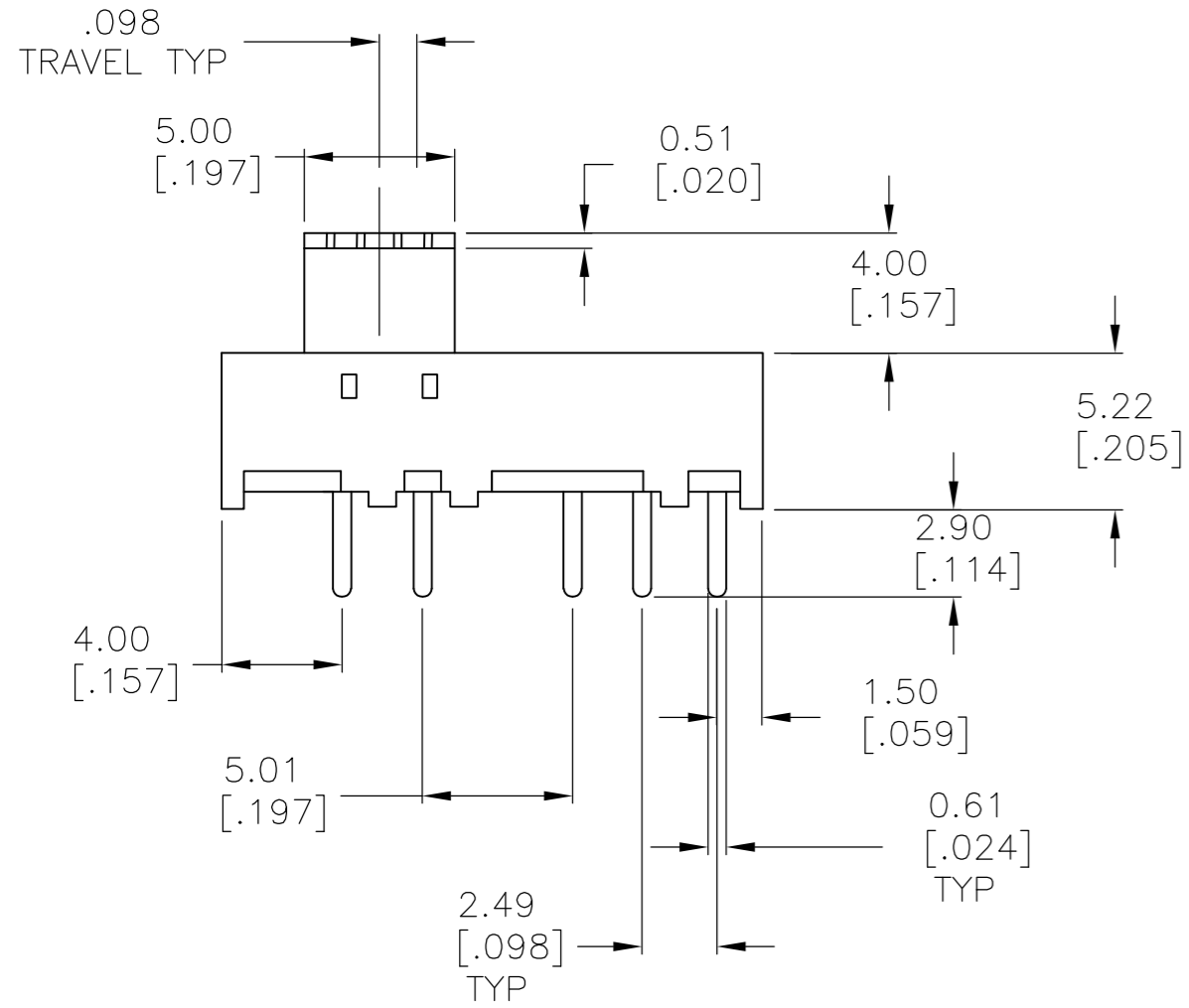

RECOMENDED HOLE LAYOUT
 TOLERANCE ± 0.002 UNLESS OTHERWISE NOTED

1-3 6-8	2-3 7-8	3-4 8-9	3-5 8-10	<table border="1"> <tr><td>1</td><td>2</td><td>3</td><td>4</td><td>5</td></tr> <tr><td>•</td><td>•</td><td>•</td><td>•</td><td>•</td></tr> <tr><td>•</td><td>•</td><td>•</td><td>•</td><td>•</td></tr> <tr><td>6</td><td>7</td><td>8</td><td>9</td><td>10</td></tr> </table>	1	2	3	4	5	•	•	•	•	•	•	•	•	•	•	6	7	8	9	10	DP4T	STS2400PC04	1825165-1
1	2	3	4	5																							
•	•	•	•	•																							
•	•	•	•	•																							
6	7	8	9	10																							
				BOTTOM VIEW	FUNCTION	T&B PART NUMBER	PART NUMBER																				
FUNCTION DIAGRAM																											

THIS DRAWING IS A CONTROLLED DOCUMENT.		DWN B.S.VISWESWARA	18MAR05	TE Connectivity																					
DIMENSIONS: mm [INCHES]		CHK M.S.SARVER	APVD -					NAME SLIDE SWITCH (DP4T) STS2400PC SERIES																	
TOLERANCES UNLESS OTHERWISE SPECIFIED:		PRODUCT SPEC -		APPLICATION SPEC -																					
<table border="1"> <tr><td>0 PLC</td><td>±</td><td>-</td></tr> <tr><td>1 PLC</td><td>±</td><td>-</td></tr> <tr><td>2 PLC</td><td>±</td><td>0.20 [.008]</td></tr> <tr><td>3 PLC</td><td>±</td><td>-</td></tr> <tr><td>4 PLC</td><td>±</td><td>-</td></tr> <tr><td>ANGLES</td><td>±</td><td>1°</td></tr> </table>		0 PLC	±	-	1 PLC	±	-	2 PLC	±	0.20 [.008]	3 PLC	±	-	4 PLC	±	-	ANGLES	±	1°	WEIGHT -		SIZE A2	CAGE CODE 00779	DRAWING NO C=1825165	RESTRICTED TO -
0 PLC	±	-																							
1 PLC	±	-																							
2 PLC	±	0.20 [.008]																							
3 PLC	±	-																							
4 PLC	±	-																							
ANGLES	±	1°																							
MATERIAL SEE NOTES		FINISH SEE NOTES		SCALE 4:1		SHEET 1 of 1	REV A2																		
CUSTOMER DRAWING																									