

REVISIONS					
REV	ECO	DESCRIPTION	DATE	BY	APPR
A	-	RELEASE	10/07/13	DRP	-

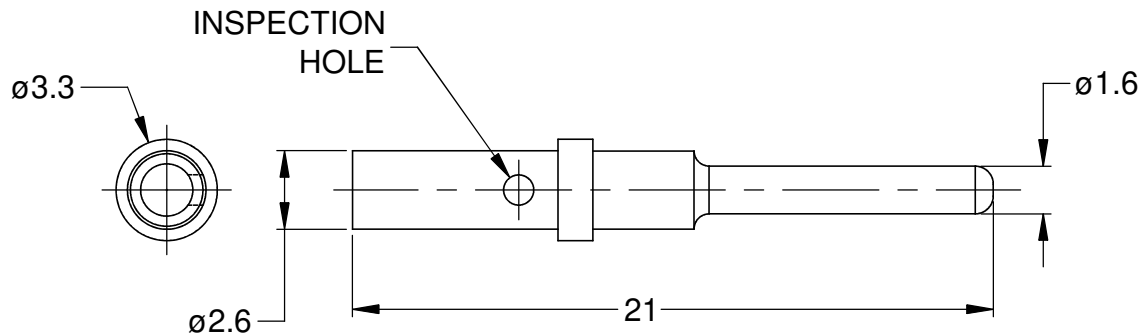

REFERENCE DIMENSIONS

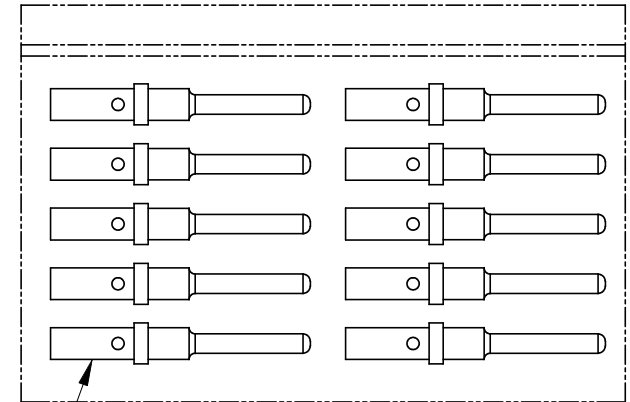

KIT CONTENTS



NOTES: UNLESS OTHERWISE SPECIFIED

1. MATERIAL: COPPER ALLOY; NICKEL PLATED
2. CONTACT SIZE: 16
3. SPECIFICATIONS:
 - 3.1 CURRENT RATING: 13 AMPS
 - 3.2 CONTACT MILLIVOLT DROP: 60 MILLIVOLT DROP @ 13 AMP TEST CURRENT.
 - 3.3 RoHS COMPLIANT
4. RECOMMENDED WIRE RANGE: 16 - 20 AWG
5. AVAILABLE HAND CRIMPER: CA-5D12
6. ALL DIMENSIONS ARE FOR REFERENCE USE ONLY

10	AT60-202-16141	CONTACT, PIN, SOLID, SIZE 16	1
	PART NUMBER	DESCRIPTION	ITEM
QUANTITY	MATERIALS LIST		
UNLESS OTHERWISE SPECIFIED	SIGNATURES	DATE	<h1>Amphenol</h1> <p>Sine Systems - www.amphenol-sine.com 44724 Morley Drive Clinton Township, MI 48036</p> <p>KIT, SIZE 16 SOLID PIN, 16-20 AWG, AT & AHD-9 SERIES, 10 PCS</p>
1) All dimensions are in metric(mm).	DRAWN: D.PARKS	10/07/13	
2) Tolerances are as follows: 1 PL DEC ±0.30 2 PL DEC ±0.15 3 PL DEC ±0.08	CHECKED:		
Fractions ±1/64 Angles ±1°	ENGINEER:		
3) Note reference =	APPROVAL:		
MATERIAL SPECIFICATIONS:	CUSTOMER:		
PROCESS SPECIFICATIONS:	THIS DRAWING IS SUPPLIED FOR INFORMATION ONLY. DESIGN FEATURES, SPECIFICATIONS AND PERFORMANCE DATA SHOWN HEREON ARE THE PROPERTY OF THE AMPHENOL CORPORATION. NO RIGHTS OF REPRODUCTION ARE IMPLIED. ALL DIMENSIONS ARE SUBJECT TO NORMAL MANUFACTURING VARIATIONS.		
NEXT ASS'Y:	SIZE	TYPE	REVISION
	A	C-	A
	SCALE: NONE	DWG NO: AT60-202-16NKIT	
		SHEET 1 OF 1	