

REVISIONS					
REV	ECO	DESCRIPTION	DATE	BY	APPR
A1	-	RELEASE NEW DRAWING	28JUL17	JONY	TOMMY
A2	-	ADD REF P/N & CRIMP TOOL	22/MAR/21	MILO	TOMMY

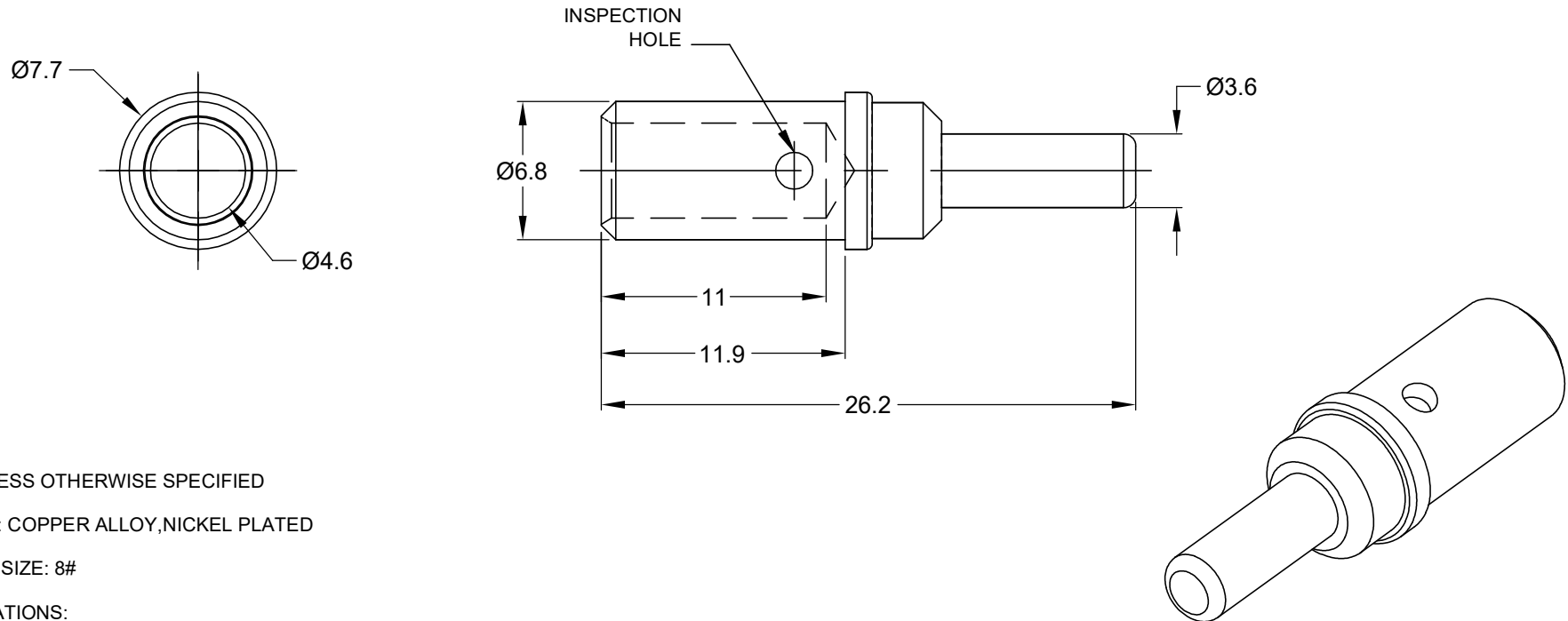

NOTES: UNLESS OTHERWISE SPECIFIED

1. MATERIAL: COPPER ALLOY,NICKEL PLATED
2. CONTACT SIZE: 8#
3. SPECIFICATIONS:
 - 3.1 CURRENT RATING: 60 AMP
 - 3.2 CONTACT MILLIVOLT DROP: 60 MILLIVOLT DROP @ 60 AMP TEST CURRENT.
 - 3.3 ROHS COMPLIANT
4. RECOMMENDED WIRE RANGE: 8 - 10 AWG(8.0-5.0mm²)
5. AVAILABLE PNEUMATIC CRIMP TOOL:WA23
6. ALL DIMENSIONS ARE FOR REFERENCE USE ONLY

TITLE: CONTACT PIN, SIZE 8, 8-10 AWG
DWG NO.: AT60-204-08141
REV: A2
SH: 1
QC: 1

AT60-204-08141		REFERENCE:0460-204-08141									
PART NUMBER		DESCRIPTION									
QUANTITY		ITEM									
MATERIALS LIST											
UNLESS OTHERWISE SPECIFIED 1) All dimensions are in metric(mm). 2) Tolerances are as follows: 1 PL DEC ±0.30 2 PL DEC ±0.15 3 PL DEC ±0.08 Fractions ±1/64 Angles ±1° 3) Note reference =		SIGNATURES DATE DRAWN: MILO DONG 22/MAR/21 CHECKED: ORICALLI 23/MAR/21 ENGINEER: APPROVAL: TOMMY XIE 24/MAR/21 CUSTOMER:									
MATERIAL SPECIFICATIONS:		 Sine Systems - www.amphenol-sine.com 44724 Morley Drive Clinton Township, MI 48036									
PROCESS SPECIFICATIONS:											
NEXT ASSY:		CONTACT PIN, SIZE 8, 8-10 AWG <table border="1"> <tr> <td>SIZE</td> <td>TYPE</td> <td>DWG NO.</td> <td>REVISION</td> </tr> <tr> <td>B</td> <td>C-</td> <td>AT60-204-08141</td> <td>A2</td> </tr> </table>		SIZE	TYPE	DWG NO.	REVISION	B	C-	AT60-204-08141	A2
SIZE	TYPE	DWG NO.	REVISION								
B	C-	AT60-204-08141	A2								
		SCALE: NONE	SHEET 1 OF 1								