

- Half Turn Trimmers
- Air Trimmers
- Glass Trimmers
- PTFE Trimmers
- Sapphire Trimmers
- Quartz Trimmers
- Non-Magnetic Trimmers
- Non-Magnetic Chip Capacitors
- Non-Magnetic Coils
- Non-Magnetic Diodes
- Non-Magnetic Hardware

# *Trimmer Capacitors & Non-Magnetic Components*



# Introduction to Voltronics Corporation

Voltronics has been supplying high performance multi-turn trimmers since 1963. Our range of trimmers are suitable for applications that require high precision, mechanically stable with a high tolerance to vibration and shock. Our success is based on a unique sealed, non-rotating piston design that has become one of the designers preferred choices for demanding applications.

As well as our extensive range of standard products we are able to design and manufacture customized products for our specialty customers. In addition we are able to offer a range of half turn trimmers suitable for less stringent applications, but still providing good stability and voltage handling capabilities.

For more than 30 years Voltronics has been partnered with leading MRI manufacturers, supporting them with the highest quality non-magnetic components. This has grown from just supplying trimmer capacitors to now include a broad offering of non-magnetic components focussed on MRI applications.



# Contents

---

<b>Half Turn Ceramic SM Chip Trimmers</b>	
Product Guide .....	2
JZ & JZ_HV Series .....	3
JR & JR_HV Series.....	4
JV Series .....	5
JQ & JN Series .....	6
Q Data Charts & Engineering Kits .....	7
<b>Precision Air/ PTFE/ Sapphire Trimmers</b>	
Product Guide .....	8
A & E Series Standard Air Trimmers .....	9
K & KE Series Air Trimmers .....	10
A1 & A3 Series Low Cost PTFE Trimmers.....	11
A2 & A4 Series Low Cost Miniature Trimmers .....	12
A_HV & E_HV Series High Voltage PTFE Trimmers .....	13
K_HV & KE_HV Series High Voltage PTFE Trimmers .....	14
A Series Very High Voltage PTFE Trimmers .....	15
NT Series Ultra High Voltage PTFE Trimmers .....	15
Air/PTFE Trimmers Lead Styles .....	16
P series High Q Sealed Sapphire Trimmers .....	17
<b>Glass and Quartz Trimmers</b>	
General Specifications.....	18
S Series - Smallest Sealed Glass Trimmers.....	19
H Series - Extended Range Glass Trimmers .....	20
TF Series - Vertical P.C. Mount Glass Trimmers .....	21
TM & QM Series - Panel Mount Glass & Quartz Trimmers.....	22-23
TP & QP Series - Horizontal P.C. Mount Glass & Quartz Trimmers.....	24-25
Differential Glass Trimmers .....	26
Split Stator Glass Trimmers .....	26
Engineering Prototype Kits - Air/PTFE/Sapphire & Glass Trimmer Capacitors .....	27
<b>Precision Microwave Tuners</b>	
DRO - Microwave Tuners for Dielectric Resonator.....	28
Precision Microwave Cavity Tuners.....	29
<b>Non-Magnetic Components &amp; Hardware</b>	
Trimmers - Product Guide .....	30
PTFE Trimmers - NT Series Ultra High Voltage .....	31
Sapphire Trimmer - V9000 Sub-miniature.....	32
Multilayer Capacitors - Product Guide.....	33
Multilayer Capacitors - General Specifications .....	34
High Q Multilayer Capacitors - 5 Series .....	35
High Q Multilayer Capacitors - 11 Series.....	36
High Q Multilayer Capacitors - 25 Series.....	37
High Q Multilayer Capacitors - 38 Series.....	38
Coils - Product Guide .....	39
Diodes - RF Actuated Diode Switch.....	40
Hardware - Screws/Nuts/Washers.....	41

---

# Product Guide - Half Turn Ceramic Chip Trimmers

Product Line	Actual Size Length x Width x Height	Part Number	Cap. Range Min. - Max. pF	Temperature Coefficient	SRF GHz	Mounting	Page
JZ & JZ_HV*	0.177 x 0.126 x 0.059 in 4.5 x 3.2 x 1.5 mm	JZ030	1.5 - 3.0	0±200	2.1	Surface	3
		JZ060	2.0 - 6.0	0±300	1.5		
		JZ080	3.0 - 8.0	-750±500	1.25		
		JZ100	2.0 - 10.0	0±300	1.16		
		JZ150	3.0 - 15.0	0±300	0.92		
		JZ200	4.5 - 20.0	0±500	0.81		
		JZ300	5.5 - 30.0	-1500±1000	0.7		
		JZ400	8.0 - 40.0	-1500±1000	0.6		
* Note: We now offer the series in a HIGH VOLTAGE VERSION. The JZ_HV series specifications are identical to the specifications listed above with this important exception: DC Working Voltage 350DC, Withstanding Voltage 750.							
JR & JR_HV*	0.138 x 0.122 x 0.045 in 3.5 x 3.1 x 1.15 mm	JR030	1.5 - 3.0	0±200	2.9	Surface	4
		JR060	2.0 - 6.0	0±300	2.05		
		JR080	3.0 - 8.0	-750±500	1.8		
		JR100	2.0 - 10.0	0±300	1.6		
		JR150	3.0 - 15.0	0±300	1.3		
		JR200	4.5 - 20.0	0±500	1.15		
		JR300	5.5 - 30.0	-1500±1000	0.92		
		JR400	8.0 - 40.0	-1500±1000	0.84		
JV	0.126 x 0.098 x 0.049 in 3.2 x 2.5 x 1.25 mm	JV010	0.5 - 1.0	0±300	4.6	Surface	5
		JV025	0.65 - 2.5	0±300	2.9		
		JV030	1.5 - 3.0	0±300	2.6		
		JV060	2.5 - 6.0	0±300	1.9		
		JV100	3.0 - 10.0	0±300	1.4		
		JV200	4.5 - 20.0	-750±500	1.0		
		JV250	5.5 - 25.0	-750±500	0.9		
		JV450	8.0 - 45.0	-1000±500	0.6		
JQ	0.106 x 0.087 x 0.04 in 2.7 x 2.2 x 1.0 mm	JQ060	3.0 - 6.0	0±300	1.6	Surface	6
		JQ100	3.5 - 10.0	0±300	1.2		
		JQ200	7.0 - 20.0	-750±500	0.9		
JN	0.067 x 0.059 x 0.035 in 1.7 x 1.5 x 0.9 mm	JN010 JN015	0.55 - 1.0	0±300	6.0	Surface	6
		JN040	0.7 - 1.5	0±300	4.8		
		JN080	1.5 - 4.0	0±300	2.7		
			3.0 - 8.0	-750±500	1.8		
Engineering Kits and Q Data Charts							7

# JZ & JZ\_HV - Ceramic Chip Trimmer Capacitors



Dimensions - Drawing tolerances where not specified  $\pm 0.008"/0.2\text{mm}$

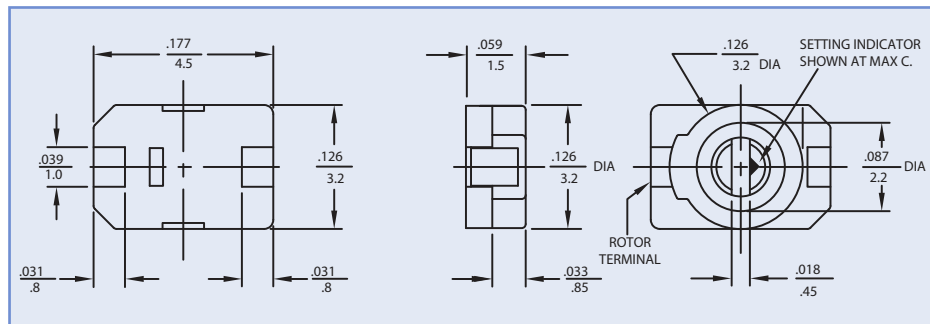

## General Specifications

Part Number - JZ series	JZ030	JZ060	JZ080	JZ100	JZ150	JZ200	JZ300	JZ400	JZ500
DC Working Voltage	125	125	125	125	125	125	125	125	125
DC Withstanding Voltage	250	250	250	250	250	250	250	250	250

Part Number - JZ_HV	JZ030HV	JZ060HV	JZ080HV	JZ100HV	JZ150HV	JZ200HV	JZ300HV	JZ400HV
DC Working Voltage	350	350	350	350	350	350	350	350
DC Withstanding Voltage	700	700	700	700	700	700	700	700

Capacitance (pF)	Minimum	Maximum	1.5 3.0	2.0 6.0	3.0 8.0	2.0 10.0	3.0 15.0	4.5 20.0	5.5 30.0	8.0 40.0	8.0 50.0
Marking Color			Black	Blue	Violet	White	Pink	Red	Orange	Yellow	Green
Temperature Coefficient (ppm/°C)			0 $\pm$ 200	0 $\pm$ 300	-750 $\pm$ 500	0 $\pm$ 300	0 $\pm$ 300	0 $\pm$ 500	-1500 $\pm$ 1000	-1500 $\pm$ 1000	-1500 $\pm$ 1000
Q (min.) at 1 Mhz			500	1000	1500	1500	1500	1500	1500	1500	1500
Self Resonant Frequency at Maximum Rated Capacitance			2.1 GHz	1.5 GHz	1.25 GHz	1.16 GHz	0.92 GHz	0.81 GHz	0.70 GHz	0.60 GHz	0.53 GHz
Insulation Resistance	10 <sup>4</sup> megohms										
Operating Temperature	-40°C to +85°C										
Torque	0.14 to 1.0 in-oz										
Packaging	All parts furnished on 12mm tape and reel. 1,000 pcs. per reel.										

## Solder Pad Layout

Recommended thickness of solder paste 0.15mm

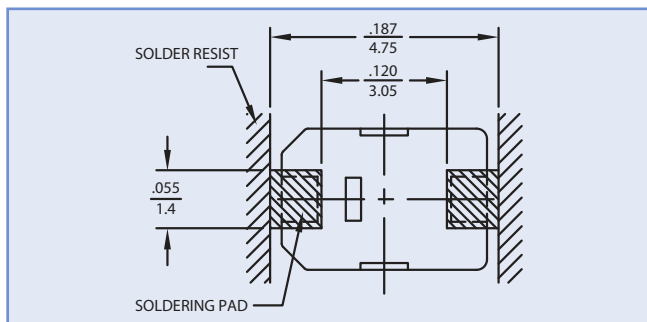

## Recommended Reflow Solder Temperature Profile

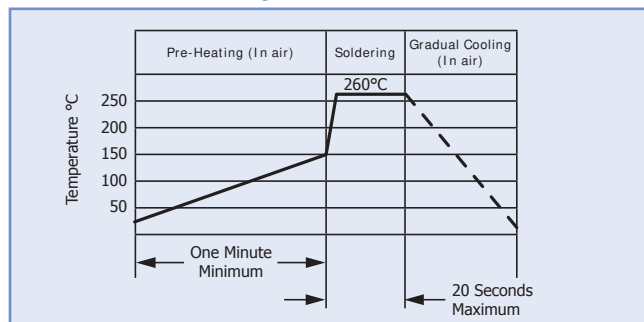

## Recommended Tuning Tools

### Ceramic Tipped: TT-400

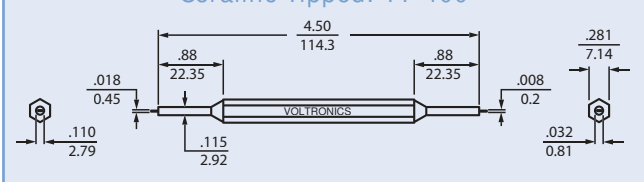

### Ceramic Tipped: TT-900

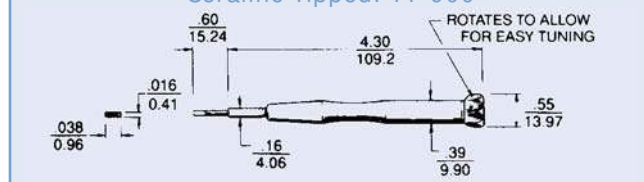

# JR & JR\_HV - Ceramic Chip Trimmer Capacitors



Dimensions - Drawing tolerances where not specified  $\pm 0.008"/0.2\text{mm}$

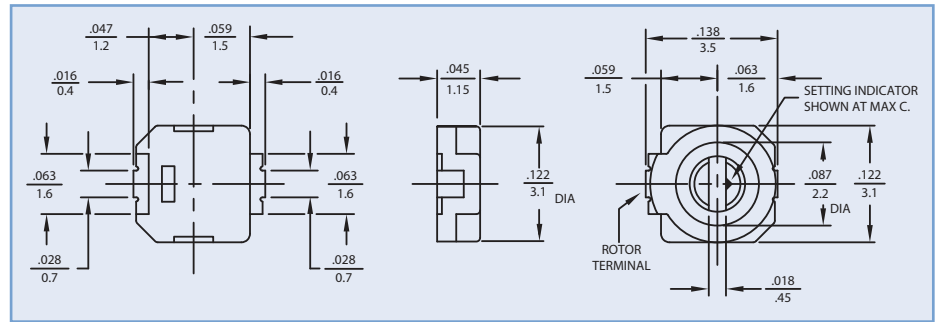

## General Specifications

Part Number - JR series	JR030	JR060	JR080	JR100	JR150	JR200	JR300	JR400
DC Working Voltage	125	125	125	125	125	125	125	125
DC Withstanding Voltage	250	250	250	250	250	250	250	250

Part Number - JR_HV	JR030HV	JR060HV	JR080HV	JR100HV	JR150HV	JR200HV	JR300HV	JR400HV
DC Working Voltage	350	350	350	350	350	350	350	350
DC Withstanding Voltage	700	700	700	700	700	700	700	700

Capacitance (pF)	Minimum	1.5	2.0	3.0	2.0	3.0	4.5	5.5	8.0
	Maximum	3.0	6.0	8.0	10.0	15.0	20.0	30.0	40.0
		+50%	+50%	+50%	+100%	+100%	+100%	+100%	+100%
		-0%	-0%	-0%	-0%	-0%	-0%	-0%	-0%
Marking Color		Black	Blue	Violet	None	Pink	Red	Orange	Yellow
Temperature Coefficient (ppm/°C)		0 ± 200	0 ± 300	-750 ± 500	0 ± 300	0 ± 500	0 ± 500	-1500 ± 1000	-1500 ± 1000
Q (min.) at 1 Mhz		500	1000	1500	1500	1500	1500	1500	1500
Self Resonant Frequency at Maximum Rated Capacitance		2.9 GHz	2.05 GHz	1.8 GHz	1.6 GHz	1.3 GHz	1.15 GHz	0.92 GHz	0.84GHz
Insulation Resistance		10 <sup>4</sup> megohms							
Operating Temperature		-40°C to +85°C							
Torque		0.6 in-oz max.							
Packaging		All parts furnished on 12mm tape and reel. 1,000 pcs. per reel.							

### Solder Pad Layout

Recommended thickness of solder paste 0.15mm

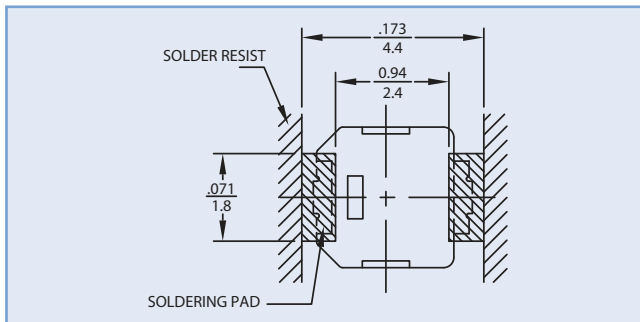

### Recommended Reflow Solder Temperature Profile

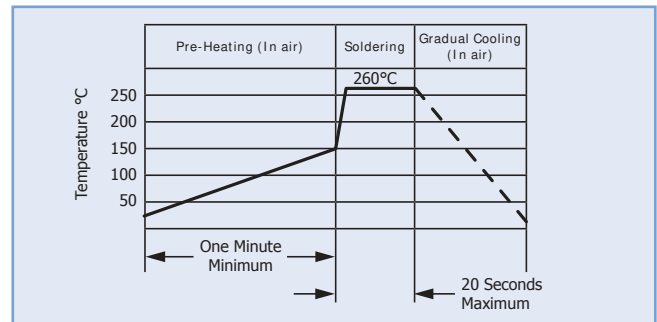

### Recommended Tuning Tools

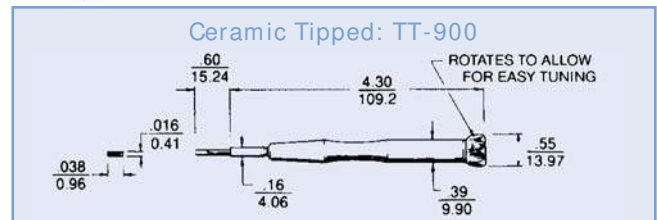
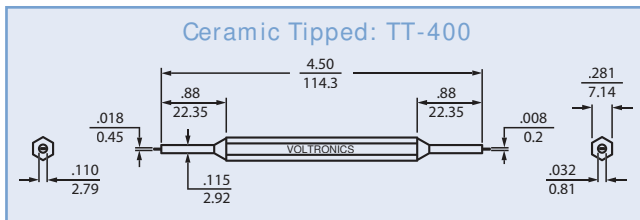



# JV - Ceramic Chip Trimmer Capacitors



Dimensions - Drawing tolerances where not specified  $\pm 0.020"/0.5\text{mm}$

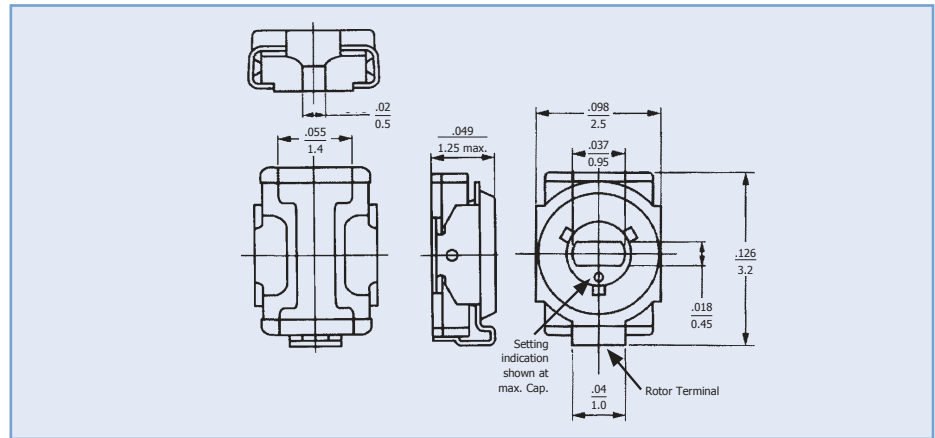

## General Specifications

Part Number - JV Series	JV010	JV025	JV030	JV060	JV100	JV200	JV250	JV450
DC Working Voltage	25	25	25	25	25	25	25	25
DC Withstanding Voltage	55	55	55	55	55	55	55	55

Capacitance (pF)	Minimum Maximum	+100% -0%	0.5 1.0	0.65 2.5	1.5 3.0	2.5 6.0	3.0 10.0	4.5 20.0	5.5 25.0	8.0 45.0
Marking Color	None									
Temperature Coefficient (ppm/°C)	0 ± 300									
Q (min.) at 1 Mhz	500									
Self Resonant Frequency at Maximum Rated Capacitance	4.6 GHz									
Insulation Resistance	10 <sup>4</sup> megohms									
Operating Temperature	-25°C to +85°C									
Torque	0.6 in-oz max.									
Packaging - 8mm tape and reel	2,000 pcs. per reel.									

### Solder Pad Layout

Recommended thickness of solder paste 0.15mm

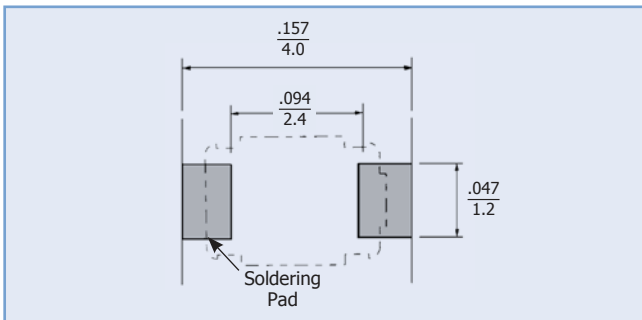

### Recommended Reflow Solder Temperature Profile

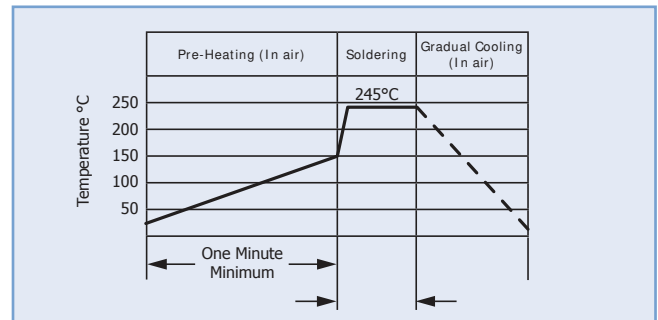

### Recommended Tuning Tools

Ceramic Tipped: TT-930

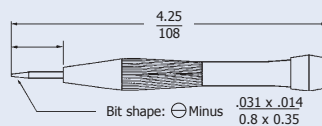

# JQ & JN SERIES - Ceramic Chip Trimmer Capacitors

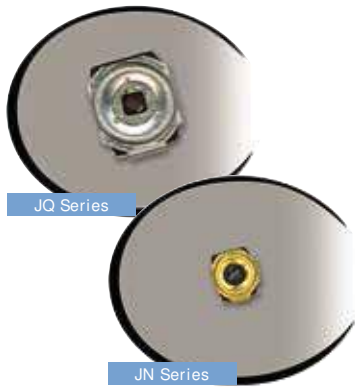

Dimensions - Drawing tolerances where not specified  $\pm 0.020"/0.5\text{mm}$

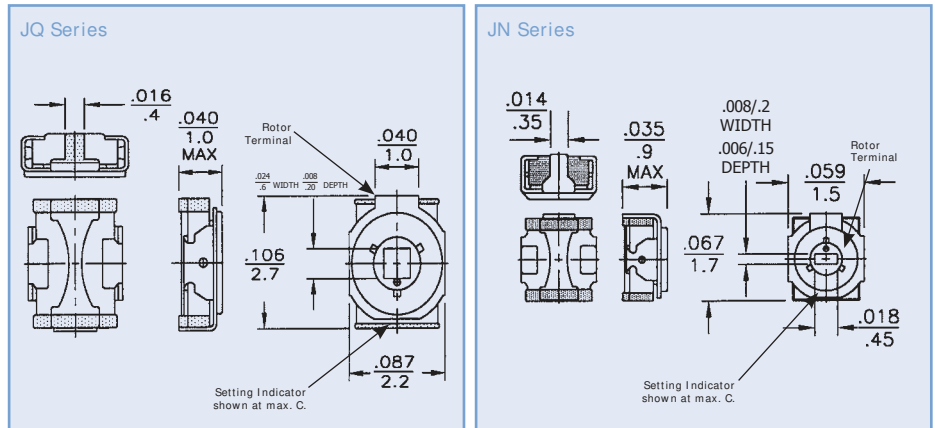

## General Specifications

Part Number	JQ060	JQ100	JQ200	JN010	JN015	JN040	JN080	
DC Working Voltage	25	25	25	25	25	25	25	
DC Withstanding Voltage	$+100\%$ $-0\%$ 55	55	55	55	55	55	55	
Capacitance (pF)	Minimum Maximum	3.0 6.0	3.5 10.0	7.0 20.0	0.55 1.0	0.7 1.5	1.5 4.0	3.0 8.0
Marking Color	None	None	None	None	None	None	None	
Temperature Coefficient (ppm/°C)	$0 \pm 300$	$0 \pm 300$	$-750 \pm 500$	$0 \pm 300$	$0 \pm 300$	$0 \pm 500$	$-750 \pm 500$	
Q (min.) at 1 Mhz	500	500	500	500	500	300	300	
Self Resonant Frequency at Maximum Rated Capacitance	1.6 GHz	1.2 GHz	0.9 GHz	6.0 GHz	4.8 GHz	2.7 GHz	1.8 GHz	
Insulation Resistance	$10^4$ megohms			$10^4$ megohms				
Operating Temperature	$-25^\circ\text{C}$ to $+85^\circ\text{C}$			$-25^\circ\text{C}$ to $+85^\circ\text{C}$				
Torque	.07 to 7.0 in-oz			.014 to .14 in-oz				
Packaging - 8mm tape and reel	3,000 pcs. per reel.			3,000 pcs. per reel.				

**Solder Pad Layout**  
Recommended thickness of solder paste 0.15mm

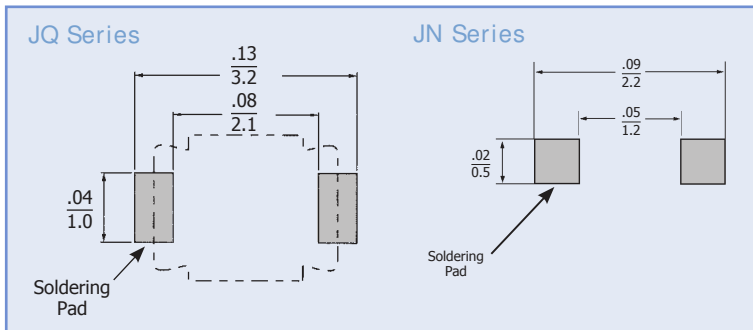

**Recommended Reflow Solder Temperature Profile**

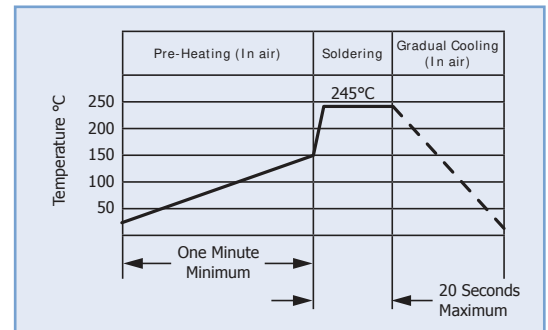

**Recommended Tuning Tools**

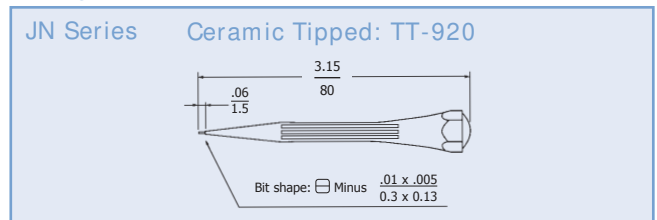
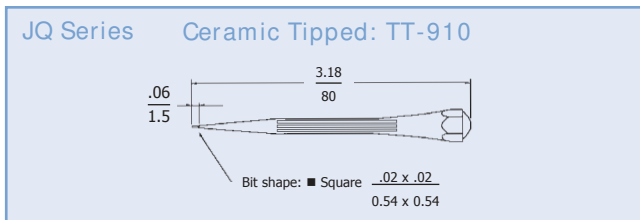



# Q Data Charts & Engineering Kits

Quality Factor (Q) of "JZ" Series Capacitors

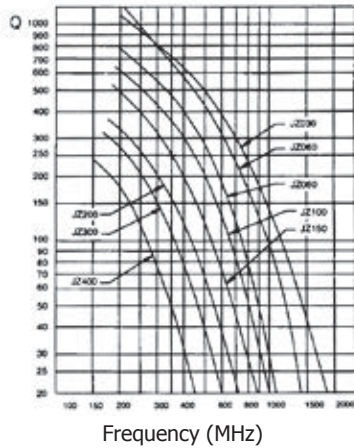

Quality Factor (Q) of "JR" Series Capacitors

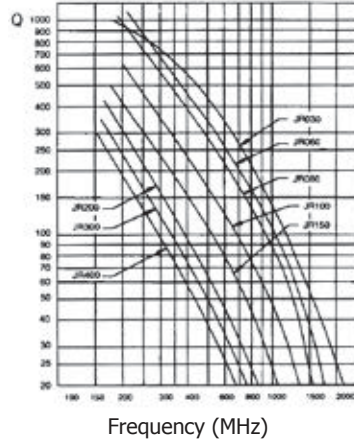

Quality Factor (Q) of "JV" Series Capacitors

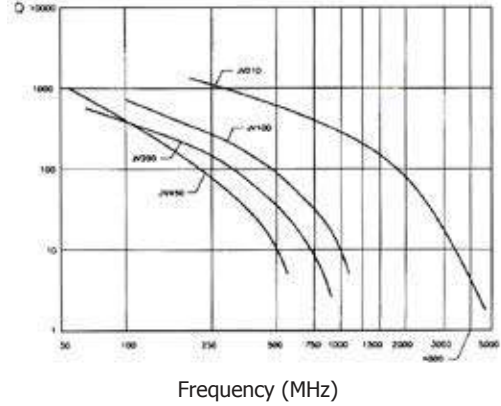

Quality Factor (Q) of "JQ" Series Capacitors

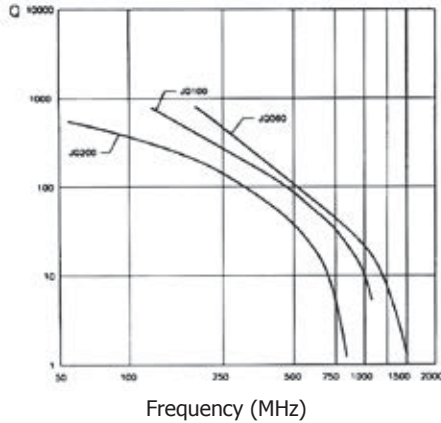

Quality Factor (Q) of "JN" Series Capacitors

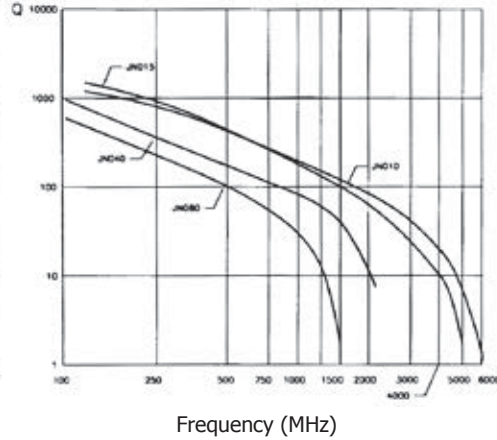

## Engineering Kits

Kit #	Quantity	Description
JZ Kit*	4	Each Capacitance Range
JZ-HV Kit*		
JR Kit*	4	
JR-HV Kit*	4	
JV Kit**	5	
JQ Kit**	5	
JN Kit**	5	

J-Series engineering kits are a great way to become familiar with our products. Each kit contains 4 or 5 units of every value. Please be sure to inquire about tuning tools when ordering.

\* Tuning tools are included with this kit.

\*\*Tuning tools are not included with this kit.

## Washing Instructions:

The J-Series trimmer capacitors can withstand cleaning cycles up to 10 PSI and have been used by customers for more than a decade in many diverse environmental conditions. Without knowing your particular washing or cleaning environment, we recommend these basic guidelines:

- 1) Water wash or isopropyl alcohol cleaning agents are acceptable providing that baths are clean and uncontaminated. For maximum effectiveness, the cleaning process should occur immediately after soldering.
- 2) Either brush or spray methods are acceptable.
- 3) \* Drying out components with forced hot air is highly recommended.
- 4) Also, we do recommend turning the tuning screw 3 or 4 complete revolutions prior to arriving at the final "set."

\* If a water wash process is used and water does get inside, we recommend that the parts be heated above 100C for a minimum of 15 minutes, so that the water evaporates. After this, the rotor should be turned 1-2 times to redistribute the internal grease.

# Product Guide - Air/ PTFE/ Sapphire Trimmer Capacitors

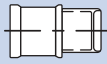
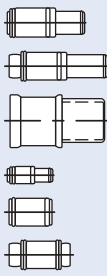
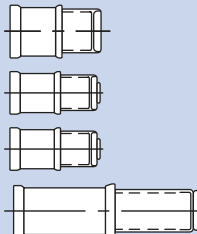
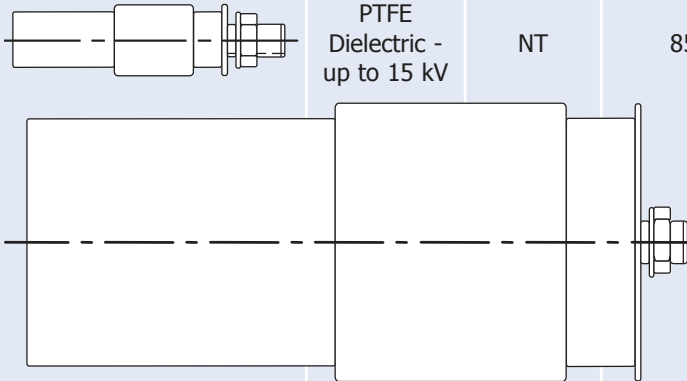
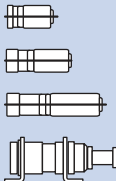
Product Line	Actual Size	Description	Series	Maximum Capacitance (pF)	Typical Self-Resonant Frequency (Max)	Surface Mount	Page
A E K		Air Dielectric	A E K & KE	14 10 10	1.5 GHz 1.3 GHz 1.3 GHz	yes yes yes	9 9 10
A1_4/8 A1_12 A3 A2 A4_3 A4_5		Low Cost PTFE Dielectric	A1 A1 A3 A2 A4 A4	12 12 10 1.2 5 5	2.3 GHz 2.3 GHz 2.3 GHz 5.0 GHz 4.3 GHz 4.3 GHz	yes yes yes yes yes yes	11 11 11 12 12 12
A_HV E_HV K_HV A_HV Ext. Range		High Voltage PTFE Dielectric	A_HV E_HV K & KE_HV A_HV	30 9 9 55	1.5 GHz 1.3 GHz 1.3 GHz .90 GHz	yes yes yes yes	13 13 14 15
NT Min.  NT Max.		PTFE Dielectric - up to 15 kV	NT	85	500 MHz	no	15
P3 P5 P8 V9000		Sapphire Dielectric	P3 P5 P8 V9000	2.5 4.5 8 12	7.5 GHz 4.0 GHz 1.5 GHz	yes yes yes yes	17 17 17 32

N.B. Most of the above trimmer capacitors can be ordered as non-magnetic - see non-magnetic section.

# A & E - Standard AIR Trimmer Capacitors



## The Only Internally-Sealed Air Trimmer

Voltronics' concentric ring air trimmer capacitors are designed for use at frequencies up to 1.5 GHz. They are ideal for applications such as mobile radios, aerospace communication, crystal oscillators and filters, radar, cable TV and innumerable other commercial and military programs. The unique internal O-ring seal make wave soldering and vapor degreasing possible without the need to attach a separate cap.

Available in two styles:

"A" Series - Solder sealed and qualified to MIL-C-14409.

"E" Series - Epoxy sealed for economical commercial applications.

### Other features include:

- Ten full linear turns
- Internal stops
- Extreme stability under shock & vibration
- Screw head does not move in and out
- Extended shaft option of metal or plastic
- Long life with no dynamic tuning noise

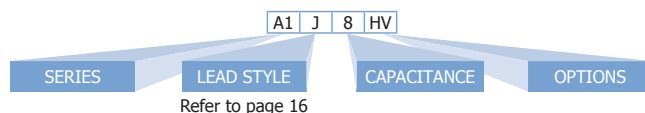

### Note:

All parts shown here can be ordered as non-magnetic:

Add "NM" to Part Number, i.e., NMAP10

General Specifications	A_5 E_5	A_10 E_10HV	A_14 E_14
Capacitance Range	1-5 pF / 1.0-10 pF	1-10 pF / 1.0-10 pF	1-14 pF / 1.0-14 pF
Q (min) at 100MHz @ Max. C*	5,000	5,000	3,000
DC Working Voltage	250	250	125
DC Withstanding Voltage	500	500	250
Temperature Coefficient	50±50 ppm/°C / -50±50 ppm/°C	50±50 ppm/°C / -50±50 ppm/°C	50±50 ppm/°C / -50±50 ppm/°C
Insulation Resistance @ 25°C	10 <sup>6</sup> megohms	10 <sup>6</sup> megohms	10 <sup>6</sup> megohms
Seal	40 pounds/in <sup>2</sup>	40 pounds/in <sup>2</sup>	40 pounds/in <sup>2</sup>
Operating Temperature	-65°C to +125°C	-65°C to +125°C	-65°C to +125°C
Rotational Life	10000 Turns	10000 Turns	10000 Turns
Tuning Torque	.05 to 5.0 in-oz	.05 to 5.0 in-oz	.05 to 5.0 in-oz
Shock	1,500g, 0.5 millisecs.	1,500g, 0.5 millisecs.	1,500g, 0.5 millisecs.
Vibration	50g at 10-2000 Hz	50g at 10-2000 Hz	50g at 10-2000 Hz

\* Self-resonant frequency and Q are assured with no terminals on parts.

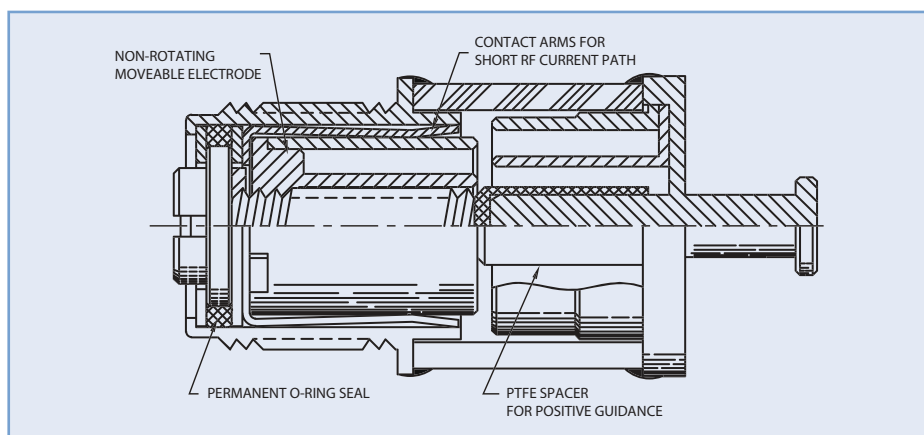

# K & KE - Air Trimmer Capacitors

	Part Number		Capacitance (pF)	
	"K" Series	"KE" Series	From Below	To Above
<b>FIG. 1</b> 	KP8	KEP8	0.6	8.0
	KP10	KEP10	0.6	10.0
<b>FIG. 2</b> 	KF8	KEF8	0.6	8.0
	KF10	KEF10	0.6	10.0
<b>FIG. 3</b> 	KT8	KET8	0.6	8.0
	KT10	KET10	0.6	10.0
<b>FIG. 4</b> 	KJ8	KEJ8	0.6	8.0
	KJ10	KEJ10	0.6	10.0
<b>FIG. 5</b> 	KT8L	KET8L	0.6	8.0
	KT10L	KET10L	0.6	10.0
<b>FIG. 6</b> 	KG8	KEG8	0.6	8.0
	KG10	KEG10	0.6	10.0
<b>FIG. 7</b> 	KM8	KEM8	0.6	8.0
	KM10	KEM10	0.6	10.0

Note: All bushing threads are .190"-64

IN	MM	IN	MM	IN	MM	IN	MM
0.015	0.38	0.067	1.70	0.160	4.06	0.260	6.60
0.030	0.76	0.070	1.78	0.180	4.57	0.270	6.86
0.036	0.91	0.080	2.03	0.190	4.83	0.280	7.11
0.040	1.02	0.093	2.36	0.200	5.08	0.300	7.62
0.045	1.14	0.110	2.79	0.230	5.84	0.590	14.99
0.060	1.52	0.140	3.56	0.240	6.10		
0.065	1.65	0.150	3.81	0.250	6.35		

Recommended Tuning Tool: TT-100 or TT-500

# A1 & A3 - Low Cost PTFE Trimmer Capacitors

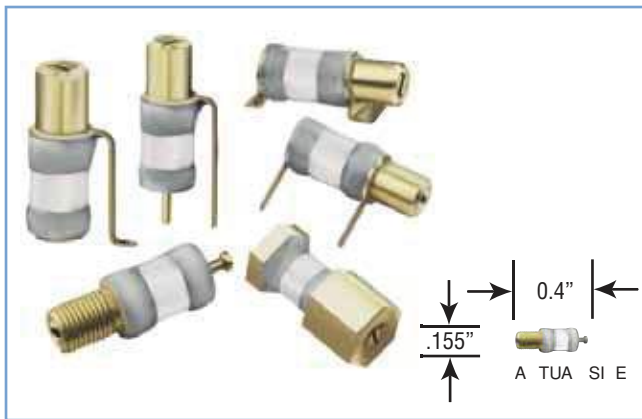

The Voltronics A1 & A3 Series of high reliability solid dielectric trimmer capacitors is an ideal economical replacement for conventional miniature air and sapphire dielectric trimmers and assures no intermittent noiseless performance.

High reliability solid dielectric, positive tuning stops and up to 13 full turns of linear tuning make the A1 Series an outstanding performer: 40 psi sealed, high voltage and non-magnetic versions are readily available.

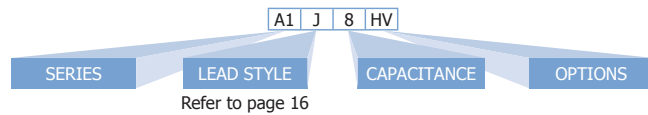

General Specifications	A1_4	A1_8	A1_12
Capacitance Range	0.45-4pF	0.5-8pF	0.6-11pF
DC Working Voltage	250	125	125
DC Withstanding Voltage	500	250	250
Self-Resonant Frequency*	2.3 GHz at 4pF	1.7 GHz at 8pF	1.2 GHz at 11pF
Number of Turns	7	7	13
Q (min) at 100 MHz @ Max. C*	4000	3000	2000
Temperature Coefficient	0±50 ppm/°C	0±100 ppm/°C	0±150 ppm/°C
Insulation Resistance @ 25° C	10 <sup>6</sup> megohms		
Operating Temperature	-65°C to +125°C		
Tuning Torque	0.3 to 1.0 in-oz		
Shock	1,500g, 0.5 millisees.		
Vibration	50g at 10-2000 Hz		

## Options

The "HV" Option - high voltage applications:  
Add "HV" to the part number, i.e., A1T4HV.

## Specifications are as follows:

Capacitance	DC Volts Working	DC Volts Withstanding
4pF	1,000	2,000
8pF	500	1,000
11pF	500	1,000

## Non-Magnetic Option:

Most parts shown can be ordered as non-magnetic.  
Add "NM" to the part number, i.e., NMA1J8.

## Sealed Option:

All parts shown can be ordered as 40 psi sealed.  
Add "S" to the part number, i.e., A1M4S.

## Tape & Reel Options:

Consult Factory - M & J style only  
Recommended Tuning Tool: TT-400

\* Self-resonant frequency and Q are assured with no terminals on parts.

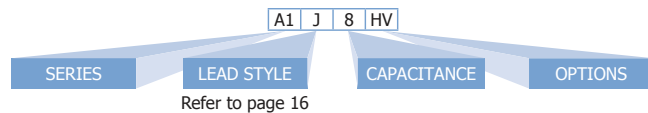
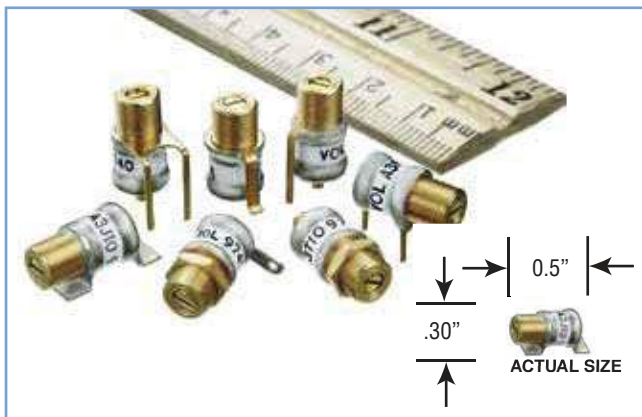

General Specifications	A3_10
Capacitance Range	1.0-10.0pF
DC Working Voltage	250
DC Withstanding Voltage	500
Self-Resonant Frequency*	2.3 GHz
Number of Turns	7
Q (min) at 100 MHz @ Max. C*	2000
Temperature Coefficient	0±50 ppm/°C
Insulation Resistance @ 25° C	10 <sup>6</sup> megohms
Operating Temperature	-65°C to +125°C
Tuning Torque	0.5 to 2.0 in-oz
Shock	1,500g, 0.5 millisees.
Vibration	50g at 10-2000 Hz

## Options

The "HV" Option - high voltage applications:  
Add "HV" to the part number, i.e., A3T10HV.

## Specifications are as follows:

DC Volts Working	DC Volts Withstanding
1,000	2,000

\* Self-resonant frequency and Q are assured with no terminals on parts.

# A2 & A4 - Low Cost Miniature PTFE Trimmer Capacitors

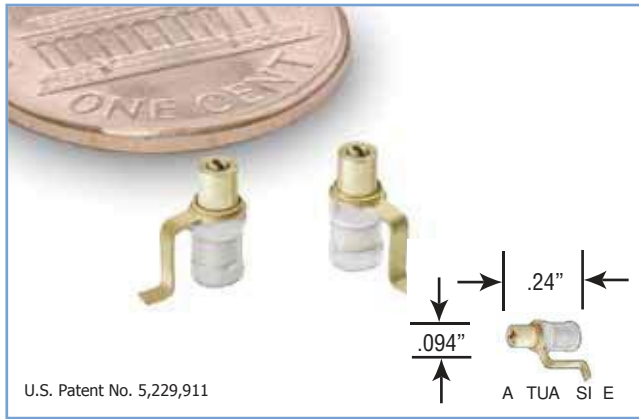

The Voltronics A2 Series is among the smallest multi-turn piston trimmer capacitors in the industry. Utilizing a high reliability solid dielectric, positive tuning stops and 3 standard mounting configurations this trimmer capacitor is an ideal replacement for expensive sapphire dielectric trimmers. Applications include tuning and impedance matching of high frequency, and high power amplifiers especially where small size and high performance are critical requirements.

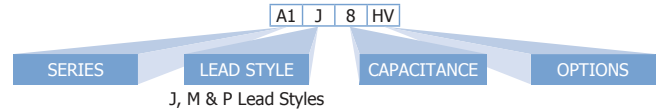

## Options

The "HV" Option - High Voltage Options:  
Add "HV" to the part number, i.e., A2M1HV.

## Specifications are as follows:

DC Volts Working	DC Volts Withstanding
1,250	2,500

## Tape & Reel Options:

Consult Factory - M & J style only

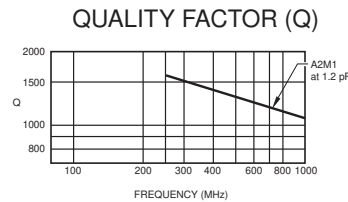

General Specifications	A2_1
Capacitance Range	0.3–1.2pF
DC Working Voltage	250
DC Withstanding Voltage	500
Self-Resonant Frequency*	5 GHz at 1.2pF
Number of Turns	7
Q (min) at 100 MHz @ Max. C*	2000
Temperature Coefficient	0±150 ppm/°C
Insulation Resistance @ 25°C	10 <sup>6</sup> megohms
Operating Temperature	-65°C to +125°C
Tuning Torque	0.1 to 1.0 in-oz
Shock	1,500g, 0.5 milliseconds.
Vibration	50g at 10-2000 Hz

\* Self-resonant frequency and Q are assured with no terminals on parts.



The Voltronics A4 Series unique design using minimal parts simplifies the manufacturing process to effect one of the most economical high performance trimmer capacitors available in the industry. The Voltronics A4 Series also features a high reliability solid dielectric, positive tuning stops and up to 5 full turns of linear tuning in the shortest length of any similar trimmer capacitor. The Voltronics A4 is an ideal choice for tuning and impedance matching, high frequency and high power amplifier circuits.

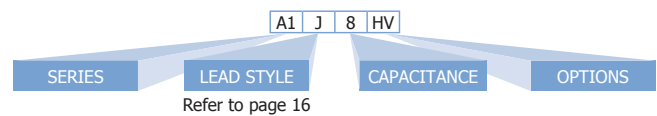

## Options

The "HV" Option - high voltage applications:  
Add "HV" to the part number, i.e., A1T4HV.

## Specifications are as follows:

Part No.	DC Volts Working	DC Volts Withstanding
A4_3 HV	500	1,000
A4_5 HV	500	1,000

Non-Magnetic Option: All parts can be ordered as non-magnetic. Add "NM" to the part number, i.e. NMA4J3

Tape & Reel Options: Consult Factory - M style only

SD Option -  
for applications requiring high reliability but lower voltage

Part No.	Working Voltage	Withstanding Voltage
K_1SD	250	500
A or K_4SD	250	500
A_25SD	125	250
A_30*	250	500
A_40SD	250	500
A_55SD	125	250

General Specifications	A4_3	A4_5
Capacitance	0.45–3pF	0.6–5pF
DC Working Voltage	125	125
DC Withstanding Voltage	250	250
Self-Resonant Frequency*	3 GHz at 3pF	1.8 GHz at 5pF
Number of Turns	4	5
Q (min) at 100 MHz @ Max. C*	3000	2000
Temperature Coefficient	0±100 ppm/°C	0±300 ppm/°C
Insulation Resistance @ 25°C	10 <sup>6</sup> megohms	
Operating Temperature	-65°C to +125°C	
Tuning Torque	0.3 to 1.0 in-oz	
Shock	1,500g, 0.5 milliseconds.	
Vibration	50g at 10-2000 Hz	

\* Self-resonant frequency and Q are assured with no terminals on parts.

Note: A\_30 not available in high voltage configuration



# A\_HV & E\_HV - High Voltage PTFE Trimmer Capacitors



## The Only Internally-Sealed HV PTFE Trimmers

Voltronics' concentric ring PTFE dielectric trimmer capacitors are designed for use at frequencies up to 1.5 GHz. They are ideal for HIGH VOLTAGE applications. The solid internal PTFE dielectric prevents ionization, a major advantage in space, high altitude and high voltage applications. The unique internal O-ring seal makes wave soldering and vapor degreasing possible without the need to attach a separate cap.

### Available in two styles:

"A\_HV" Series - Solder sealed ceramic body. "E\_HV" Series - Epoxy sealed plastic body.

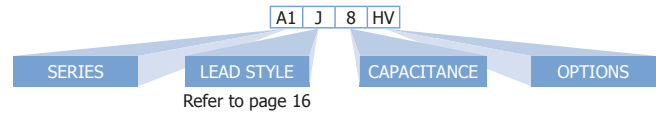

General Specifications	A_4HV / E_4HV	A_10 HV / E_10HV	A_15 HV / E_15HV	A_25 HV / E_25HV
Capacitance Range	1-4pF	1-10pF	1-16pF	1-23pF
DC Working	1000	1000	1000	750
DC Withstanding	2000	2000	2000	1500
Q (min) at 100MHz @ Max. C*	2000	2000	2000	2000
Temperature Coefficient - 0±100ppm/°C	-50±50 ppm/°C	-50±50 ppm/°C	50±50 ppm/°C	-50±50 ppm/°C
Insulation Resistance @ 25°C	10 <sup>6</sup> megohms	10 <sup>6</sup> megohms	10 <sup>6</sup> megohms	10 <sup>6</sup> megohms
Seal	40 pounds/in2	40 pounds/in2	40 pounds/in2	40 pounds/in2
Operating Temperature	-65°C to +125°C	-65°C to +125°C	-65°C to +125°C	-65°C to +125°C
Rotational Life	600 Turns	600 Turns	600 Turns	600 Turns
Tuning Torque	.05 to 5.0 in-oz	.05 to 5.0 in-oz	.05 to 5.0 in-oz	.05 to 5.0 in-oz
Shock	1,500g, 0.5 millisecons.	1,500g, 0.5 millisecons.	1,500g, 0.5 millisecons.	1,500g, 0.5 millisecons.
Vibration	50g at 10-2000 Hz	50g at 10-2000 Hz	50g at 10-2000 Hz	50g at 10-2000 Hz

\* Self-resonant frequency and Q are assured with no terminals on parts.

## Extended Range

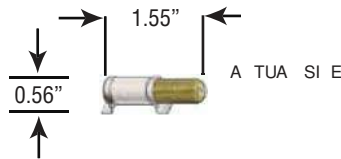

General Specifications	A_40HV	A_55HV
Capacitance Range	1.5-40pF	1.5-55pF
Q (min) at 100MHz @ Max. C*	2000	
Q (min) at 75 MHz@ Max. C*		780
Temperature Coefficient	0±100 ppm/°C	0±100 ppm/°C
Insulation Resistance @ 25°C	10 <sup>6</sup> megohms	10 <sup>6</sup> megohms
Seal	40 pounds/in2	40 pounds/in2
Operating Temperature	-65°C to +125°C	-65°C to +125°C
Rotational Life	600 Turns	600 Turns
Tuning Torque	.05 to 5.0 in-oz	.05 to 5.0 in-oz
Shock	1,500g, 0.5 millisecons.	1,500g, 0.5 millisecons.
Vibration	50g at 10-2000 Hz	50g at 10-2000 Hz
DC Working Voltage	1000	600
DC Withstanding Voltage	2000	1200

\* Self-resonant frequency and Q are assured with no terminals on parts.

Extended Metal Shaft Option: Add "E" to Part Number, i.e., AT40SE

## Other features include:

- Ten or 29 linear turns
- Internal stops
- Extreme stability under shock & vibration
- Screw head does not move in and out
- Extended shaft option of metal or plastic
- Long life with no dynamic tuning noise

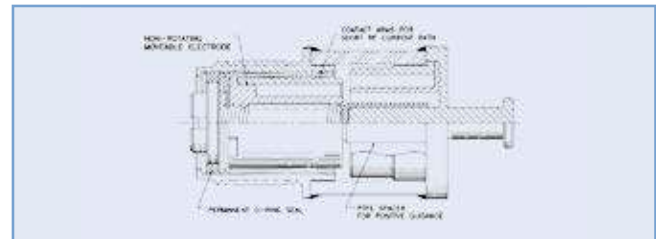

## Options

Non-Magnetic Option: All parts can be ordered as non-magnetic.

Add "NM" to the part number, i.e. NMAT25HV, NMKP10HV

Extended Shaft Options:

Add "E" to the part number, i.e. AT10HE

Extended Plastic Shaft Options:

Add "EI" to the part number, i.e. EF10HVEI

SD Option -

for applications requiring high reliability but lower voltage

Part No.	Working Voltage	Withstanding Voltage
K_1SD	250	500
A or K_4SD	250	500
A_25SD	125	250
A_30*	250	500
A_40SD	250	500
A_55SD	125	250

Note: A\_30 not available in high voltage configuration



# K\_HV & KE\_HV - PTFE Trimmer Capacitors



General Specifications	K_HV	KE_HV
Q at 1GHz at maximum rated C*	780 (1pF)	
Q at 100MHz at maximum rated C*	2000 (4 & 9pF)	2000 (4 & 9pF)
Temperature Coefficient	50±50ppm/°C	-50±50ppm/°C
Insulation Resistance	10 <sup>6</sup> megohms	10 <sup>6</sup> megohms
Seal	40 pounds/in2	40 pounds/in2
Operating Temperature	-65°C to +125°C	-65°C to +125°C
Rotational Life	600 turns	600 turns
Torque	0.5-5.0 in-oz	0.5-5.0 in-oz
Vibration	50g, 10-2000 Hz	50g, 10-2000 Hz
Shock	1500g, 0.5 milliseconds.	1500g, 0.5 milliseconds.
Drawing tolerances where not specified	XXX ± .005 XX ± .016	XXX ± .005 XX ± .016

\* Self-resonant frequency and Q are measured with no terminals on parts.

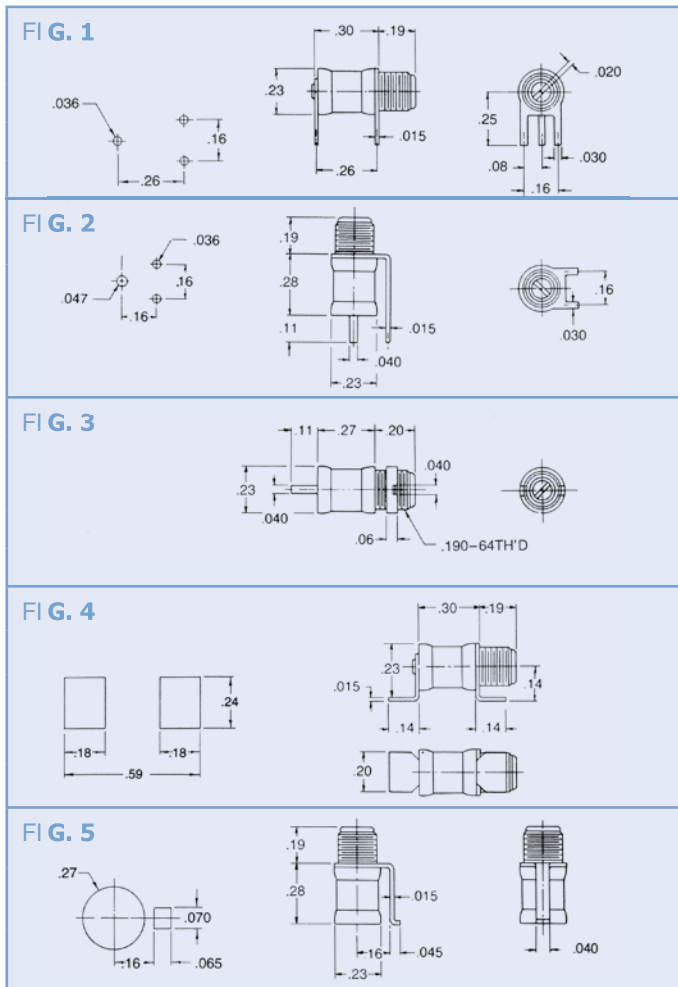

Part Number		DC Working Voltage	DC Withstanding Voltage	Capacitance (pF)	
"K" Series	"KE" Series			From Below	To Above
KP1HV		1000	2000	0.2	1
KP1SD		250	500	0.2	1
KP4HV	KEP4HV	1000	2000	0.5	4
KP4SD	KEP4SD	250	500	0.5	4
KP10HV	KEP10HV	1000	2000	0.5	9
KF4HV	KEF4HV	1000	2000	0.5	4
KF4SD	KEF4SD	250	500	0.5	4
KF10HV	KEF10HV	1000	2000	0.5	9
KT1HV		1000	2000	0.2	1
KT1SD		250	500	0.2	1
KT4HV	KET4HV	1000	2000	0.5	4
KT4SD	KET4SD	250	500	0.5	4
KT10HV	KET10HV	1000	2000	0.5	9
KJ1HV		1000	2000	0.2	1
KJ1SD		250	500	0.2	1
KJ4HV	KEJ4HV	1000	2000	0.5	4
KJ4SD	KEJ4SD	250	500	0.5	4
KJ10HV	KEJ10HV	1000	2000	0.5	9
KM4HV	KEM4HV	1000	2000	0.5	4
KM4SD	KEM4SD	250	500	0.5	4
KM10HV	KEM10HV	1000	2000	0.5	9

Note: All bushing threads are .190"-64

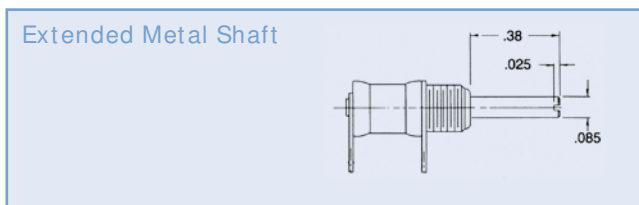

Add "E" to Part Number, i.e., KP10HVE.

IN	MM	IN	MM	IN	MM	IN	MM
0.015	0.38	0.067	1.70	0.160	4.06	0.280	7.11
0.025	0.63	0.080	2.03	0.190	4.83	0.290	7.37
0.030	0.76	0.085	2.16	0.200	5.08	0.300	7.62
0.036	0.91	0.093	2.36	0.230	5.84	0.380	9.65
0.040	1.02	0.110	2.79	0.240	6.10	0.470	11.94
0.045	1.14	0.140	3.56	0.264	6.71		
0.060	1.52	0.150	3.81	0.270	6.86		

Recommended Tuning Tool: TT-100 or TT-500

# A Series - Very High Voltage PTFE Trimmer Capacitors

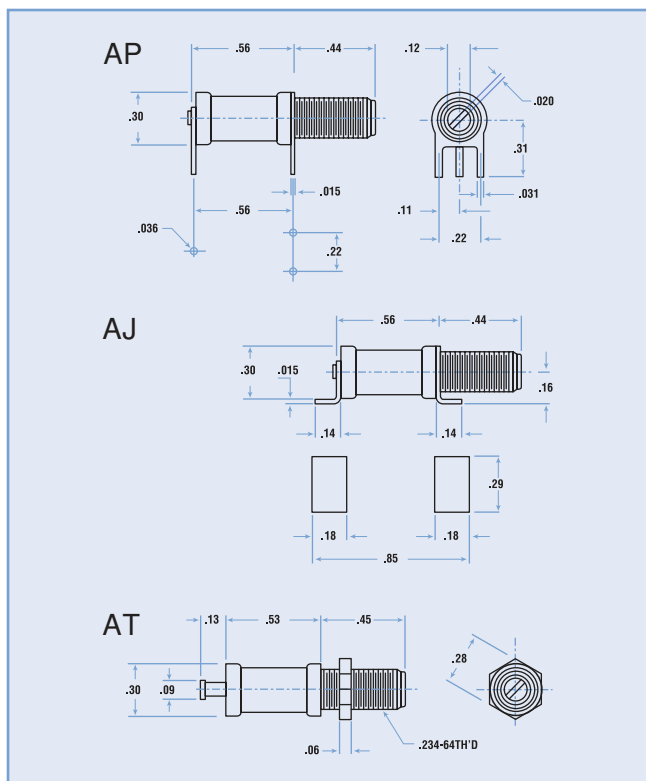

General Specifications	A_10-4	A_20-4
Capacitance Range	0.8-10pF	0.8-20pF
DC Working Voltage	2000	2000
DC Withstanding Voltage	4000	4000
Self-Resonant Frequency*	4.25 GHz at 2pF	3 GHz at 3pF
Q (min) at 100 MHz @ Max. C*	3000	3000
Temperature Coefficient	0±100 ppm/°C	0±100 ppm/°C
Insulation Resistance @ 25°C	10 <sup>6</sup> megohms	10 <sup>6</sup> megohms
Operating Temperature	-65°C to +125°C	-65°C to +125°C
Tuning Torque	0.5 to 5.0 in-oz	0.5 to 5.0 in-oz
Shock	1500g, 0.5 milliseconds.	1500g, 0.5 milliseconds.
Vibration	50g at 10-2000 Hz	50g at 10-2000 Hz
Drawing Tolerances where not specified	XXX ± .005 XX ± .016	XXX ± .005 XX ± .016

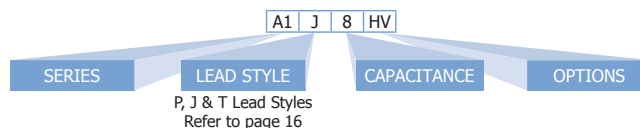

### Options:

Extended metal shaft.  
Add 'E' to the part number i.e. AT10-4E

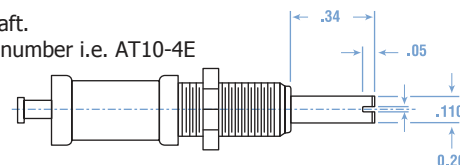

For Non-Magnetic parts add 'NM' to part number, i.e. NMAT10-4

# NT Series Ultra High Voltage PTFE Trimmer Capacitors



### 4kV to 20kV

Voltronics new "NT" series of PTFE trimmers are designed for applications requiring greater capacitance and voltage ratings than the popular smaller trimmers but without the large size and expense of vacuum capacitors.

### The "NT" Line Offers:

- High voltage
- Non-rotating piston, long life & no tuning noise
- Extremely stable under shock & vibration
- Screw head does not move in & out

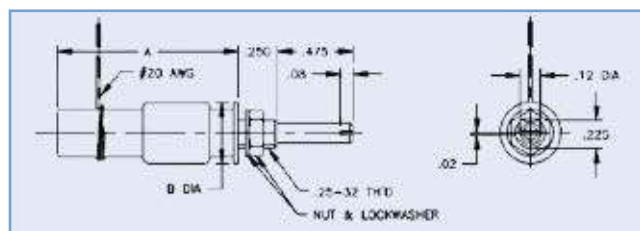

Extended Shaft Options:  
Add "E" to the part number  
e.g. NT10-5E

Part Number	DC Working Voltage	DC Withstanding Voltage	Capacitance (pF) <	Capacitance (pF) >	"A" Dim ± .06	"B" Dim ± .06
NT2-20	20000	10000	1.0	2.0	1.205	1.125
NT5-18	8750	17500	1.0	5.0	2.0	0.75
NT10-6	3000	6000	1.0	10.0	1.15	0.38
NT10-12	6000	12000	2.0	10.0	1.83	.063
NT15	2000	4000	1.0	15.0	1.69	0.31
NT25-6	3000	6000	5.0	25.0	1.62	.063
NT25-15	7500	15000	7.0	25.0	1.77	1.13
NT30	3000	6000	4.0	30.0	2.25	1.50
NT50	4500	9000	5.0	50.0	2.25	1.50
NT70-6	3000	6000	2.5	70.0	3.00	0.70
NT70-15	7500	15000	6.5	70.0	3.25	1.63
NT85	3000	6000	5.0	85.0	3.25	1.50
NT100-4	2500	3600	2.0	95.0	4.25	0.31

# AIR/ PTFE Trimmer Capacitors - Lead Styles

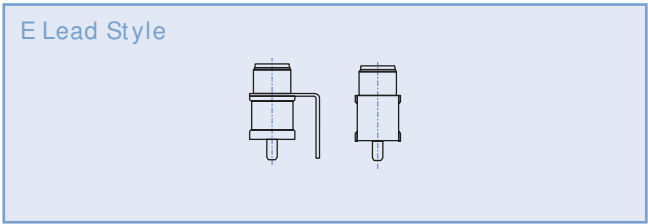
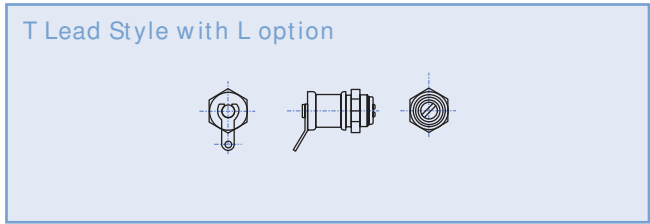
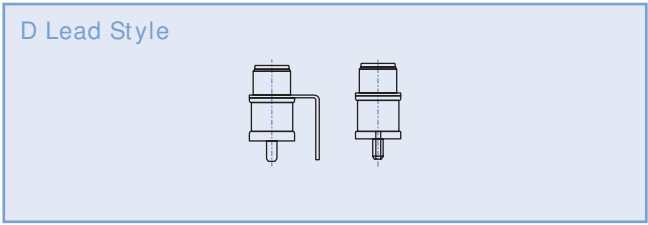
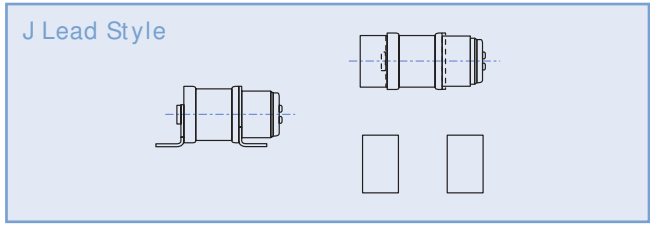
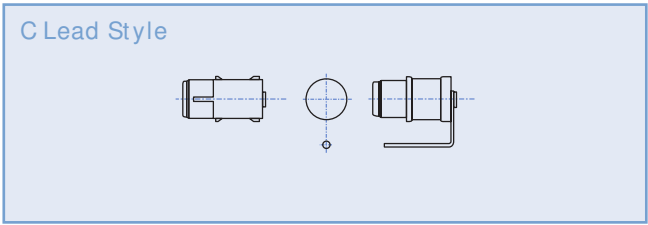
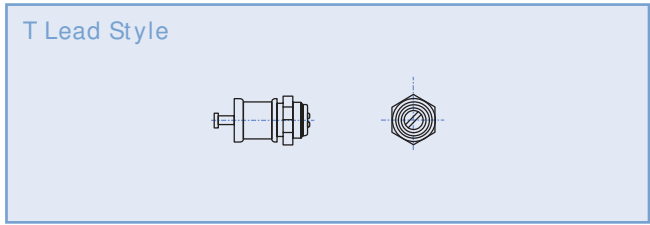
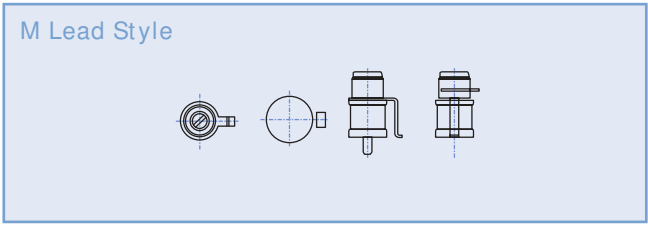
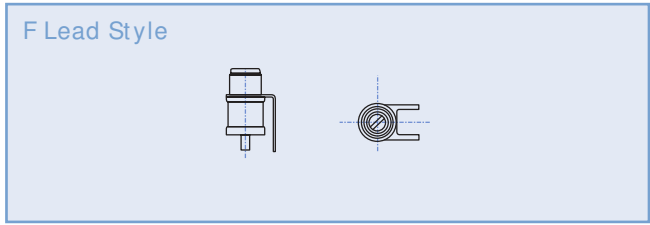
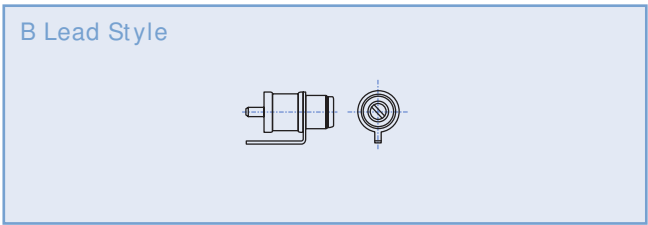
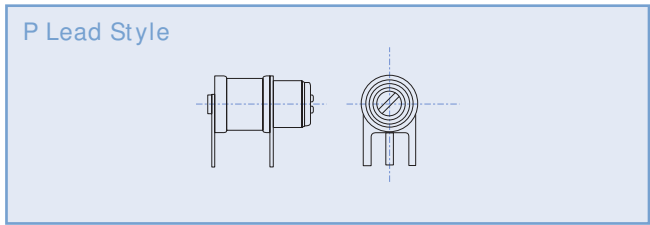

Note: All bushing threads are .234" -64

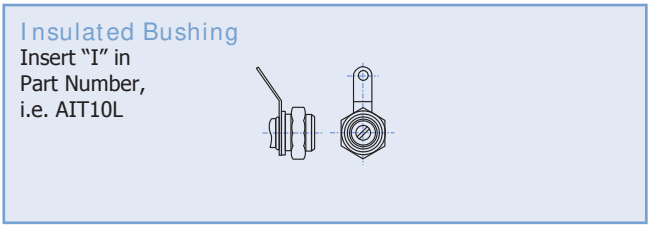
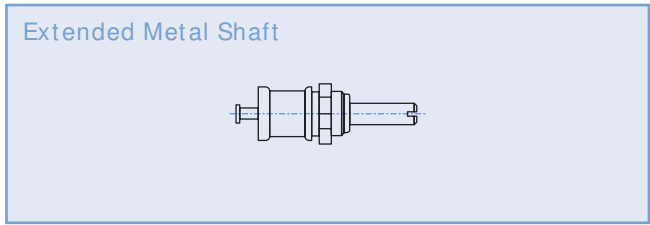

# P Series - High Q Sealed Sapphire Trimmer Capacitors



Voltronics "P" line of sapphire subminiature trimmer capacitors is unique in design. The trimmers have a high Q, zero temperature coefficient, and are internally O-ring sealed to keep out flux and cleaning fluid. Yet, sizes are the same as the MIL unsealed styles. The tuning screw does not move in and out, and RF current does not run along it. Sapphire is ideal for precision trimmer capacitors. Its dielectric constant is extremely stable and the dielectric loss is below 0.0003 over frequencies up to 10GHz. Sapphire is chemically inert, totally moisture resistant, and mechanically strong.

## Other features include:

- High Q, low temperature coefficient, and internal seal
- Low self-inductance for use to 10 GHz
- Interchangeability with unsealed designs
- Long life, no measurable tuning noise

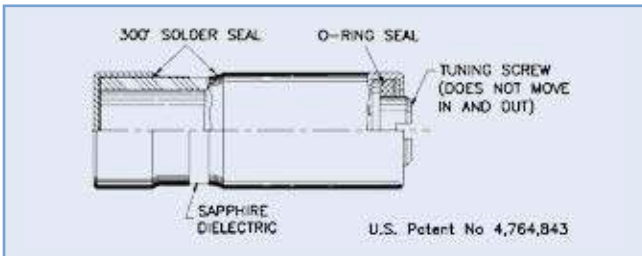

General Specifications	P Series
Capacitance	0.6-2.5/0.6-4.5/0.8-8.0pF
DC Working Voltage	500
DC Withstanding Voltage	1000
Seal	Internal O-ring
Temperature Coefficient	0 ± 50 ppm/°C
Insulation Resistance @ 25°C	10 <sup>9</sup> megohms
Operating Temperature	- 55°C to +125°C
Tuning Torque	0.2 to 2.0 in-oz
Shock	100g, 6 milliseconds.
Vibration	60g at 10-2000 Hz

Capacitance Range (pF)				Tolerances (where not specified) ± .016								
Type	Fig.	From Below	To Above	Q (Min.)	A (max)	B Dia.	C ± .005	D ± .010	E ± .010	F	G	H ± .005
P3A	1	0.6	2.5	4,000	.240	-	.118	-	-	-	-	-
P5A	1	0.6	4.5	3,000	.329	-	.118	-	-	-	-	-
P8A	1	0.8	8.0	1,500	.495	-	.118	-	-	-	-	-
P3D	2	0.6	2.5	4,000	.240	.190	.118	.100	-	-	-	-
P5D	2	0.6	4.5	3,000	.329	.190	.118	.150	-	-	-	-
P8D	2	0.8	8.0	1,500	.495	.190	.118	.230	-	-	-	-
P3B	3	0.6	2.5	4,000	.240	.140	.118	.082	.014	-	-	-
P5B	3	0.6	4.5	3,000	.329	.140	.118	.130	.034	-	-	-
P8B	3	0.8	8.0	1,500	.495	.140	.118	.250	.036	-	-	-
P3C	4	0.6	2.5	4,000	.240	.140	.118	.056	.018	-	-	.093
P5C	4	0.6	4.5	3,000	.329	.140	.118	.100	.060	-	-	.093
P8C	4	0.8	8.0	1,500	.495	.140	.118	.150	.148	-	-	.093
P3F	5	0.6	2.5	4,000	.240	.140	.118	.090	-	.110	.025	.04
P5F	5	.06	4.5	3,000	.329	.140	.118	.160	-	.110	.025	.04
P8F	5	.08	8.0	1,500	.495	.140	.118	.250	-	.110	.025	.04
P3J	6	.06	2.5	4,000	.240	.140	.118	.082	.014	0.70	.160	-
P5J	6	.06	4.5	3,000	.329	.140	.118	.130	0.34	.070	.160	-
P8J	6	.08	8.0	1,500	.495	.140	.118	.250	0.36	.070	.160	-
P3M	7	.06	2.5	4,000	.240	-	.118	-	-	-	.160	-
P5M	7	.06	4.5	3,000	.329	-	.118	-	-	-	.230	-
P8M	7	.08	8.0	1,500	.495	-	.118	.160	-	-	.230	-

## High Frequency Data

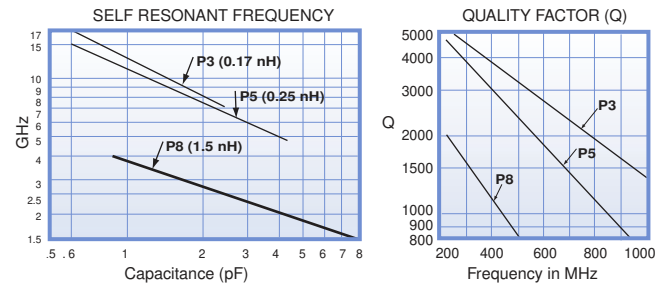

\*This high frequency data was taken on a Boonton Model 34A Resonant Coaxial-line with the parts set at their maximum rated capacitance values. Connections to the parts were made directly on the body of the capacitors.

NOTE: For diameter and length dimensions on Figures 2-7, see figure 1.

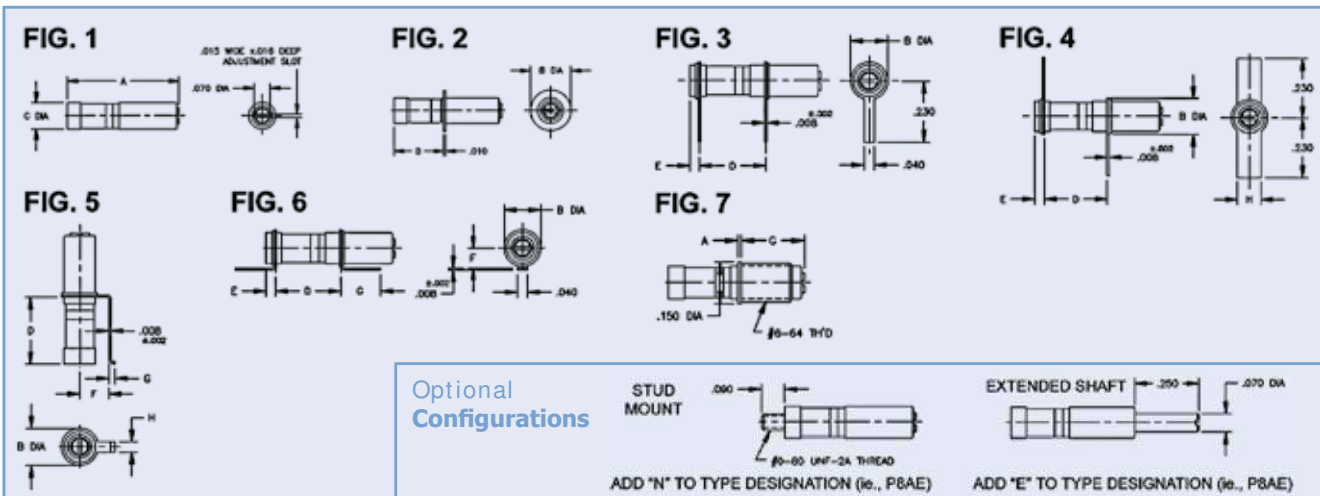

# Glass and Quartz Trimmer Capacitors

## Design Features

The unique Voltronics non-rotating precision trimmer capacitor design offers the following advantages over conventional rotating types:

- Linear tuning with no reversals
- A true high frequency device with high Q's, low RF losses, low constant inductance and high self-resonant frequencies
- A superior seal because the screw head and O-ring do not move in and out
- Greater life -10,000 cycles minimum
- Much smaller sealed MIL sizes
- Ability to provide extended metal or plastic shafts

## Dielectric

The dielectric is a tube which has been precision drawn in a vacuum so that its inner diameter is held within  $\pm 0.0002''$ . The choices are:

1. **Annular Band Glass:** A solid tube of a specially selected formulation of glass which is metallized on the outside.
2. **Embedded Band Glass:** Two tubes of glass fired together with a metallized silver band embedded between them. The inner tube is only 0.005" thick to provide much higher capacitance values.
3. **Quartz:** A pure-grade silicon oxide offering higher Q and voltage ratings in each size with the trade-off of lower capacitance and higher cost.

## General Specifications

(where not specified on detail pages)

### Piston Action

Non-rotating

### Blind Hole Tuning

Screw head does not move in and out

### Linearity

$\pm 1\%$  with no capacitance reversals

### Resolution

#2-72 tuning screw for fine tuning—approximate pico-farads per turn in active tuning range:

- |                                |            |
|--------------------------------|------------|
| 1. Annular band glass          | .6 to .8   |
| 2. Embedded band glass         | 2.3 to 3.0 |
| 3. Quartz                      | .3 to .36  |
| 4. "H" Series high range glass | 3.9 to 4.2 |

### Insulation Resistance

Annular band glass and quartz:  
10<sup>6</sup> Megohms at 25°C to 125°C  
Embedded band glass:  
10<sup>6</sup> Megohms at 25°C  
10<sup>5</sup> Megohms at 125°C

### Tuning Torque

1 to 8 inch ounces

### Life

Over 10,000 cycles

### Temperature Coefficient

Annular Band Glass:  $\pm 50$  ppm/°C  
Embedded Band Glass:  $\pm 150$  ppm/°C  
Quartz: 0 to +50 ppm/°C

### Dielectric Withstanding Voltage

Twice DC working voltage (listed with each part)

### Capacitance Tuning Range

From below minimum to above maximum value listed for each part. Capacitance measured at 1 MHz on Boonton Electronics 7600 bridge using Voltronics V1265 guarded test jig. AM measurements taken with leads perpendicular to unit regardless of final configuration.

### Temperature Range

All glass dielectrics: -55°C to 125°C  
Quartz dielectric: -55°C to 150°C

### Other Specifications

All other specifications including vibration, shock, moisture and seal (where applicable) per MIL-C-14409D

### Drawing Tolerances (where not specified)

Decimal: XXX  $\pm .016''$   
XX  $\pm .03''$

### Quality Factor

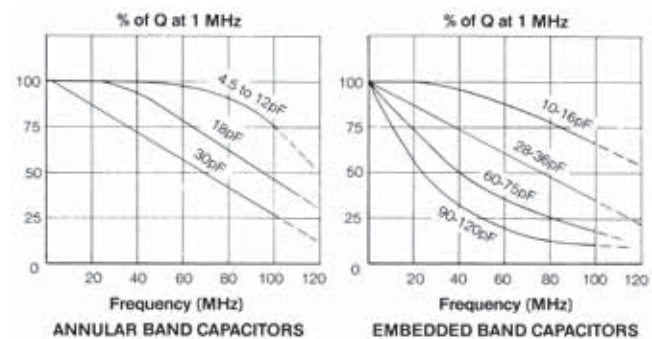

Recommended Tuning Tool: TT-100 or TT-600

# S Series - Smallest Sealed Glass Trimmer Capacitors

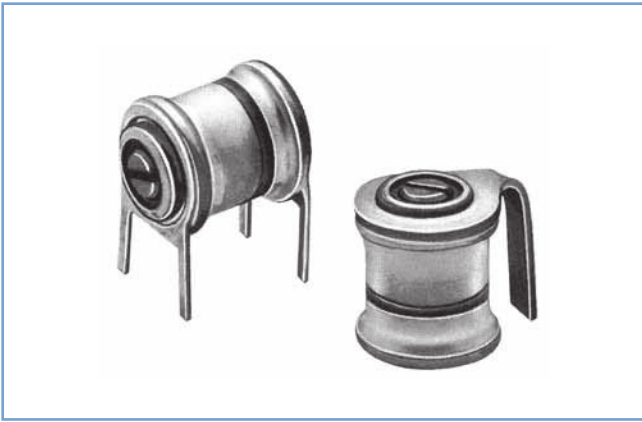

The PC17 styles are the only vertically mounted glass trimmers in MIL-C-14409D.

Voltronics "S" Series are up to 40% shorter with 25% more range than any other sealed standard glass RC. trimmers. The use of Voltronics' unique non-rotating piston design provides linear tuning, high "Q", long life, and high self-resonant frequencies. The O-ring seal assures protection up to 40 p.s.i. against dust, moisture, flux, solder, and cleaning solvents.

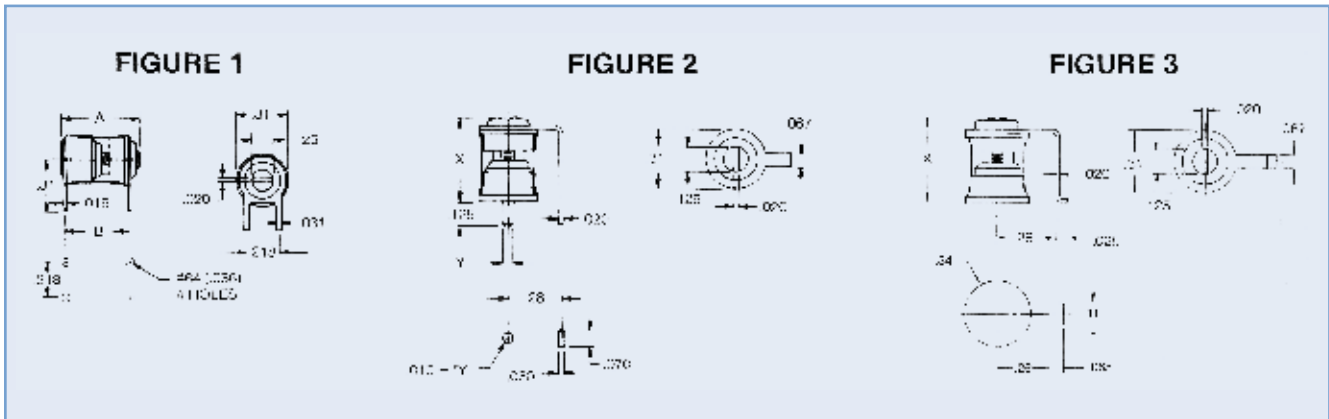

Dielectric	Capacitance Range (pF)		Q (Min.) at 1 MHz	Horizontal Mount Figure 1			Vertical Mount* Figure 2		Surface Mount Figure 3	
	From Below	To Above		Type	A ± .06	B ± .03	Type	X ± .03	Type	X ± .03
EMBEDDED BAND GLASS	1.5	10	800	SP10	.370	.300	SF10A	.340	SM10	.340
	1.5	20	800	SP20	.440	.370	SF20A	.410	SM20	.410
	1.5	30	800	SP30	.520	.450	SF30A	.490	SM30	.490
	1.5	40	800	SP40	.630	.560	SF40A	.600	SM40	.600

"Y" dimension-standard - .040". For non-standard, change "A" in type number to "B" for .063" or "C" for .093".

\*SF styles available with dual leads from top similar to AF styles on page 14.

General specifications on page 18 apply except:

1. DC Working Voltage: 250
2. Tuning torque: 0.5 to 5 inch ounces
3. Tolerance: XXX ± .005

# H Series - Extended Range Glass Trimmer Capacitors

The "H" Series increases the standard maximum capacitance values of Voltronics' glass trimmer capacitors by almost 100%. This is achieved by a new and unique technique which makes the wall of the inner glass tube thinner than was previously possible. General specifications for the "H" Series are the same as those of standard embedded band glass trimmers (see Page 18) with the following exceptions:

DC Working Voltage: 125  
 Temperature Coefficient:  $-150 \pm 150$  ppm/°C

Type	Capacitance Range (pF)		Q (Min.) at 1 MHz	Fig.	A $\pm$ .06	B $\pm$ .03
	From Below	To Above				
<b>Horizontal Printed Circuit</b>						
HSP19	2	19	1000	1	0.37	0.3
HSP34	2	34	900		0.44	0.37
HSP46	2	46	800		0.52	0.45
HSP64	2	64	700		0.63	0.56
HTP96C	2	96	600	2	0.91	0.88
HTP130C	2	130	500		1.16	1.13
HTP210C	2	210	350		1.75	1.73
HTP250C	2	250	250		1.98	1.95
<b>Vertical Printed Circuit</b>						
					A $\pm$ .03	
HSF19	2	19	1000	3	0.34	
HSF34	2	34	900		0.41	
HSF46	2	46	800		0.49	
HSF64	2	64	700		0.6	
<b>Surface Mount</b>						
HSM19	2	19	1000	4	0.34	
HSM34	2	34	900		0.41	
HSM46	2	46	800		0.49	
HSM64	2	64	700		0.6	
<b>Panel Mount</b>						
HTM19C	2	19	1000	5	0.37	
HTM34C	2	34	900		0.45	
HTM46C	2	46	800		0.52	
HTM64C	2	64	700		0.63	
HTM96C	2	96	600		0.92	
HTM130C	2	130	500		1.17	
HTM210C	2	210	350		1.77	
HTM250C	2	250	250		2	

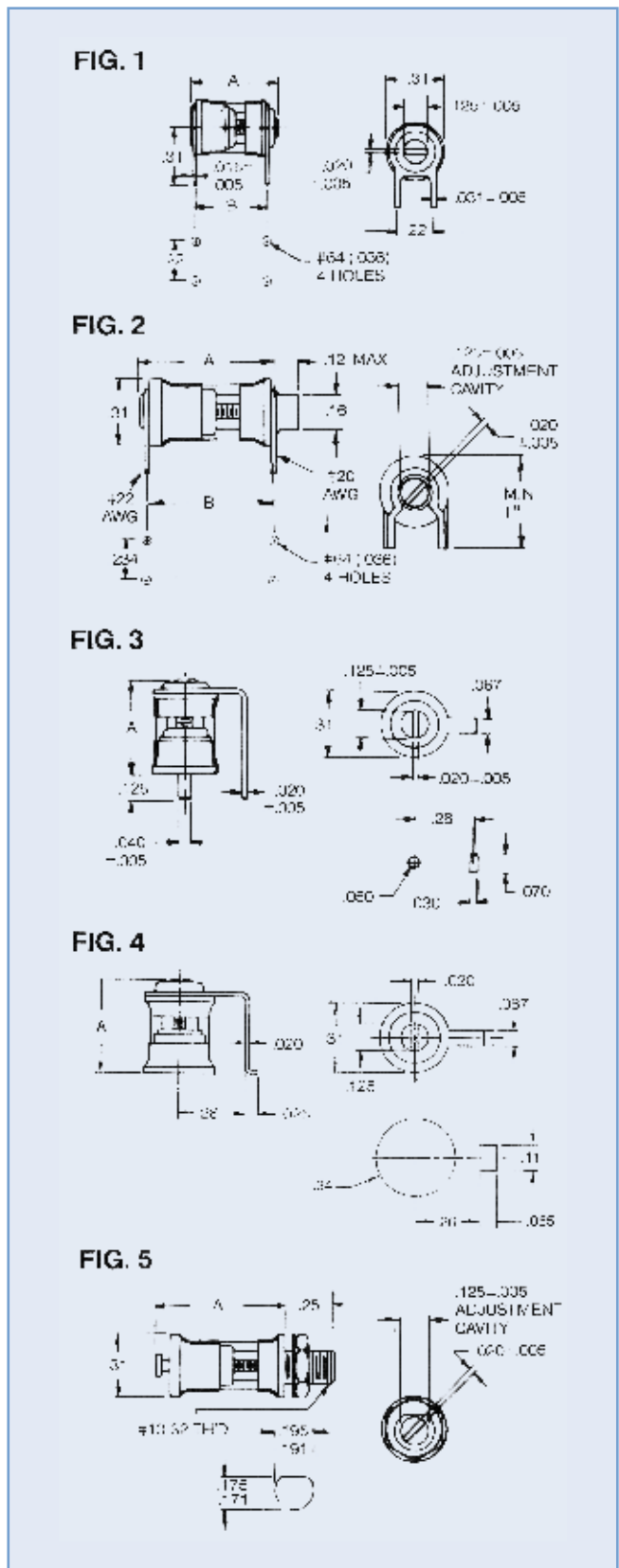



# TF Series - Vertical P.C. Mount Glass Trimmer Capacitors

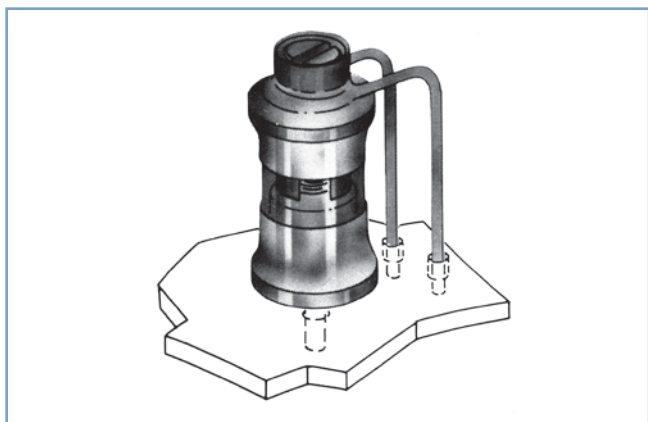

Type	Capacitance Range (pF)		$X \pm .03$	Q (Min.) at 1 MHz	DCVV
	From Below	To Above			
<b>Annular Band</b>					
TF5A	0.8	4.5	0.47	650	750
TF6A	0.8	5.5	0.47	700	750
TF8A	1	8.5	0.62	700	750
TF9A	0.8	8.5	0.7	650	750
TF11A	1	11	0.7	700	750
TF12A	0.8	12	0.9	650	750
TF17A	0.8	16	0.9	700	750
<b>Embedded Band</b>					
TF10A	1.2	10	0.43	800	500
TF14A	1.5	14	0.53	700	1000
TF15A	1.2	16	0.48	800	500
TF16A	1	16	0.53	800	1000
TF22A	2	22	0.58	800	500
TF25A	2	25	0.58	800	500
TF28A	1	28	0.77	700	1000
TF36A	1	36	0.77	800	1000

General Specifications on Page 18

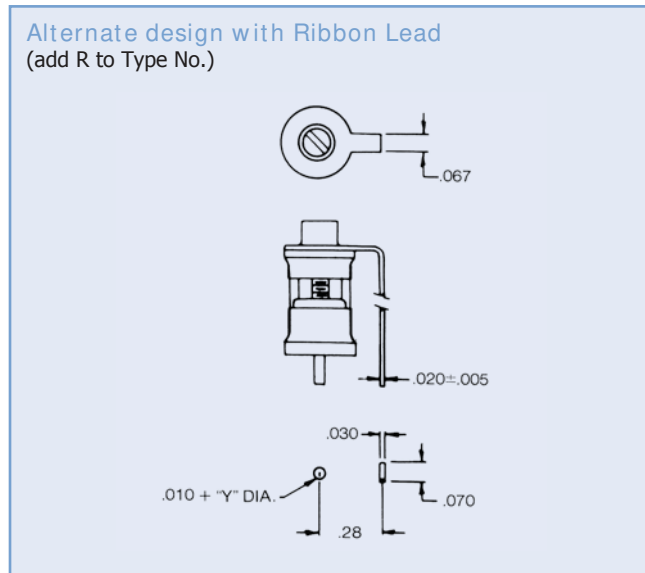
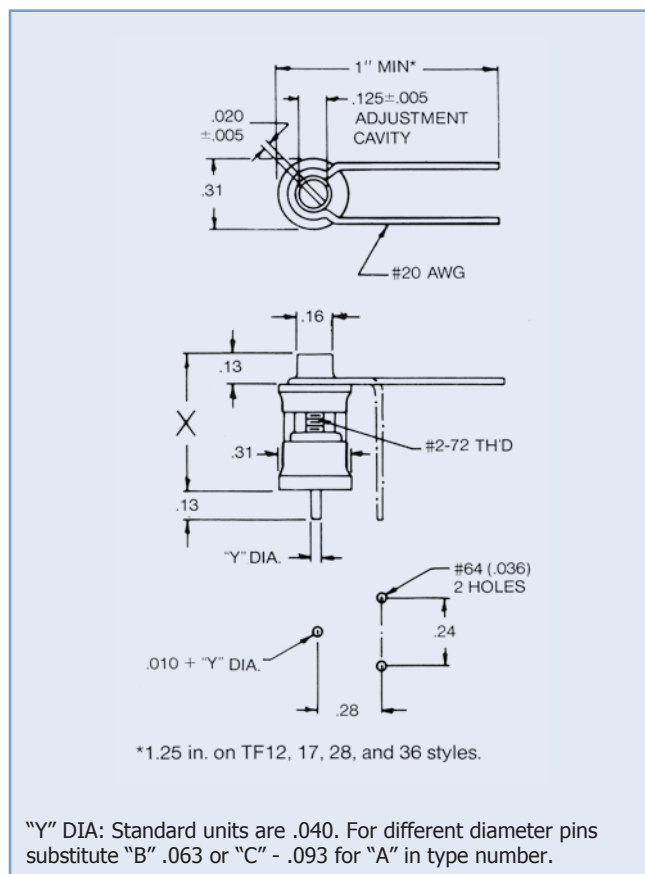

# TM & QM Series - Panel Mount Glass and Quartz Trimmer Capacitors



Fig. 1

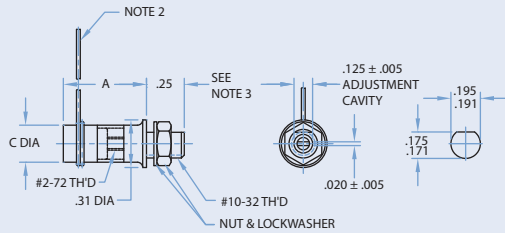

Fig. 2

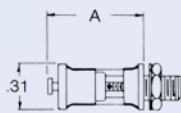

Fig. 3

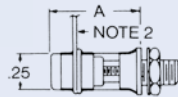
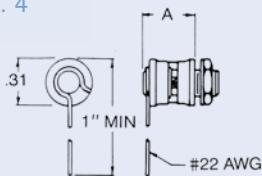

Fig. 4



## Notes:

1. Fig. 2,3 and 4 parts have same end view as Fig. 1.
2. All leads #22 AWG and 2" Min. long except for all TM5-, TM6-, TM10- and QM2- parts which are #24 AWG.
3. Mounting bushing #10-32 x .25 long except for all TM10- and TM15- parts which are #10-32 x .16 long.
4. C diameter of Fig. 1 parts .27 on embedded band units and .25 on all other parts.

Detailed General Specifications on Page 18

## Optional Configuration

### INSULATED BUSHING

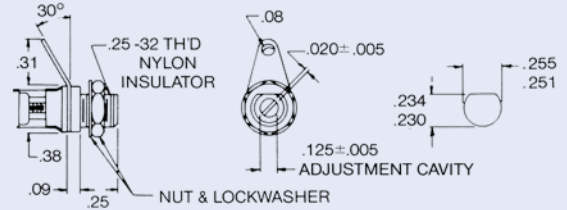

Insert "I" Between "T" and "M" in Type Number (ex. TIM9C)

### EXTENDED PLASTIC SHAFT

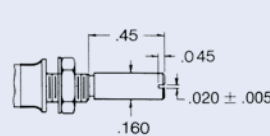

Add "EI" to End of Type Number (ie., TM9EI)

### EXTENDED METAL SHAFT

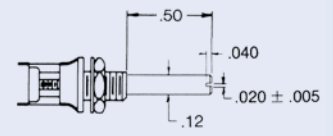

Add "E" to End of Type Number (ie., TM9CE)

# TM & QM Series - Panel Mount Glass and Quartz Trimmer Capacitors

## Glass Annular Band

Capacitance Range (pF)		Q (Min.) 1 MHz	UNSEALED 750 DCWV (Fig. 1)			SEALED, METAL CAP, TURRET TERMINAL 750 DCWV (Fig. 2)		SEALED, GLASS END 1,250 DCWV (Fig. 3)		
From Below	To Above		A± .03	Type	MIL Designation	A± .03	Type	A± .03	Type	MIL Designation
0.8	4.5	650	.31	TM5	PC40J4R5**	.41	TM5C	.36	TM5G	PC38J4R5**
0.8	5.5	700	.31	TM6	P050J5R5	.41	TM6C	.36	TM6G	PC48J5R5
0.8	8.5	650	.55	TM9	PC40J8R5**	.63	TM9C	.59	TM9G	PC38J8R5**
1.0	11.0	700	.55	TM11	PC50J110	.63	TM11C	.59	TM11G	PC48J110
0.8	12.0	650	.75	TM12	PC40H120**	.83	TM12C	.81	TM12G	PC38H120**
0.8	16.0	700	.75	TM17	PC50H160	.83	TM17C	.81	TM17G	PC48H160
0.8	18.0	650	1.00	TM18	PC40H180**	1.09	TM18C	1.06	TM18G	PC38H180**
0.8	21.0	700	1.13	TM21	—	1.22	TM21C	—	—	—
0.8	23.0	700	1.00	TM23	PC50H230	1.09	TM23C	1.06	TM23G	PC48H230
0.8	30.0	650	1.59	TM30	PC40H300**	1.69	TM30C	1.66	1M30G	PC38H300**
0.8	38.0	700	1.59	TM38	PC50H380	1.69	TM38C	1.66	TM38G	PC48H380

## Glass Embedded Band

Capacitance Range (pF)		Q (Min.) 1 MHz	UNSEALED 1,000 DCWV (Fig. 1)		SEALED, METAL CAP, TURRET TERMINAL 1,000 DCWV (Fig. 2)			SEALED, METAL CAP, 1,000 DCWV (Fig. 4)	
From Below	To Above		A± .016	Type	A± .03	Type	MIL Designation	A± .03	Type
2.0	10.0	800	.28	TM10*	.37	TM10C*	—	.35	TM10M*
1.5	14.0	700	.38	TM14	.47	TM14C	—	.45	TM14M
1.2	16.0	800	.33	TM15*	.42	TM15C*	—	.40	TM15M*
1.0	16.0	800	.38	TM16	.47	TM16C	PC39G160	.45	TM16M
2.0	25.0	800	.42	TM25	.52	TM25C	—	.50	TM25M
1.0	28.0	700	.61	TM28	.70	TM28C	—	.69	TM28M
1.0	36.0	800	.61	TM36	.70	TM36C	PC39G360	.69	TM36M
1.0	42.0	700	.83	TM42	.92	TM42C	—	.91	TM42M
1.0	52.0	800	.83	TM52	.92	TM52C	PC39G520	.91	TM52M
1.0	60.0	650	1.08	TM60	1.17	TM60C	—	1.16	TM60M
1.0	75.0	700	1.08	TM75	1.17	TM75C	PC39G750	1.16	TM75M
1.0	90.0	600	1.67	TM90	1.77	TM90C	—	1.75	TM90M
1.0	120.0	600	1.67	TM120	1.77	TM120C	P039G121	1.75	TM120M
2.0	180.0	500	1.91	TM180*	2.00	TM180C*	—	1.98	TM180M*

## Quartz

Capacitance Range (pF)		Q (Min.) 1 MHz	UNSEALED 750 DCWV (Fig. 1)			SEALED, QUARTZ END 1,250 DCWV (Fig. 3)		
From Below	To Above		A± .03	Type	MIL Designation	A± .03	Type	MIL Designation
0.6	1.8	2000	.30	QM2	PC40Q1R8	.36	QM2G	PC38Q1R8
0.8	5.5	2000	.55	QM6	P040Q5R5	.63	QM6G	PC38Q5R5
0.6	9.5	2000	.98	QM10	PC40Q9R5	1.06	QM10G	PC38Q9R5
0.8	16.0	2000	1.59	QM16	PC40Q160	1.66	QM16G	PC38Q160

\*Parts Rated 500 DCWV

\*\*MIL-C-14409B parts not listed in MIL-C-14409D

# TP & QP Series - Horizontal P.C. Mount Glass and Quartz Trimmer Capacitors

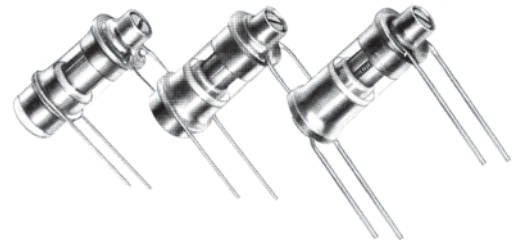

**FIG. 1**

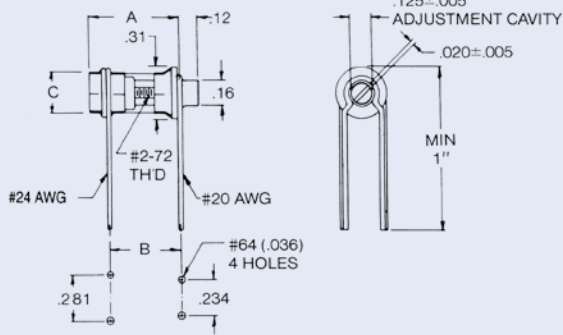

**FIG. 2**

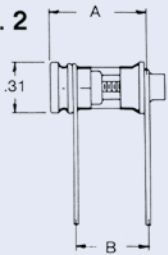

**FIG. 3**

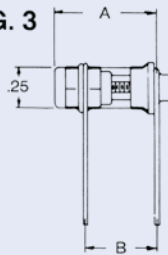

**FIG. 4**

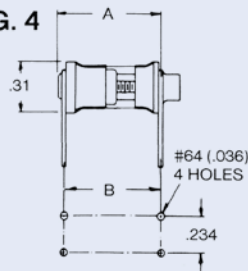

**NOTES:**

1. All Fig. 2 thru Fig. 4 parts have same end view as Fig. 1. Fig's 2 and 3 have mounting dimensions of Fig. 1
2. C diameter of Fig. 1 parts .27 for embedded band and .25 on all other parts.

Detailed General Specifications on Page 18

**Optional Configurations**

**EXTENDED PLASTIC SHAFT**

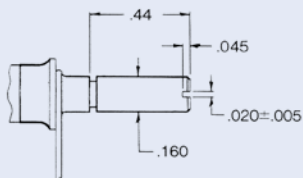

Add "E1" to Type Number  
(ex. TP9CE1)

**EXTENDED METAL SHAFT**

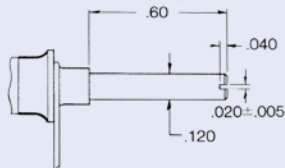

Add "E" to Type Number  
(ie., TP9E)

**PRINTED CIRCUIT LUG**

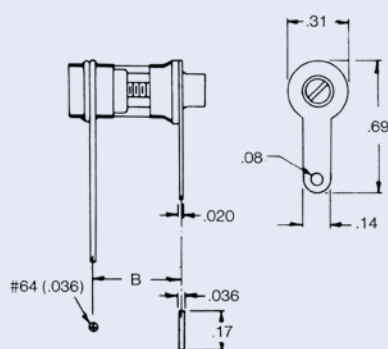

Add "L" to Type Number  
(ie., TP28L)

# TP & QP Series - Horizontal P.C. Mount Glass and Quartz Trimmer Capacitors

## Glass Annular Band

Capacitance Range (pF)		Q (Min.)	Unsealed 750 DCWV (Fig. 1)				Sealed, Metal Cap 750 DCWV (Fig. 2)			Sealed, Glass End, 1,250 DCWV (Fig. 3)						
From Below	To Above		1 MHz	A±.03	B±.03	Type	MIL Designation	A±.03	B±.03	Type	Smaller (Fig. 3)			Larger MIL Size (Fig. 3)		
										A±.03	B±.03	Type	A±.06	B±.03	Type	MIL Designation
0.8	4.5	650	.31	.25	TP5	PC41J4R5**	—	—	—	.39	.25	TP5G	.63	.50	TP5GA	PC42J4R5**
0.8	5.5	700	.31	.25	TP6	PC51J5R5	—	—	—	.39	.25	TP6G	.59	.50	TP6GA	PC52J5R5
0.8	8.5	650	.56	.44	TP9	PC41J8R5**	.58	.44	TP9C	.61	.44	TP9G	.88	.70	TP9GA	PC42J8R5**
1.0	11.0	700	.56	.44	TP11	PC51J110	.58	.44	TP11C	.61	.44	TP11G	.84	.70	TP11GA	PC52J110
0.8	12.0	650	.77	.63	TP12	PC41H120**	.78	.63	TP12C	.83	.63	TP12G	1.08	.84	TP12GA	PC42H120**
0.8	16.0	700	.77	.63	TP17	PC51H160	.78	.63	TP17C	.83	.63	TP17G	1.05	.84	TP17GA	PC52H160
0.8	18.0	650	1.03	.88	TP18	PC41H180**	1.05	.88	TP18C	1.08	.88	TP18G	1.33	1.02	TP18GA	PC42H180**
0.8	21.0	700	1.14	1.00	TP21	—	1.17	1.00	TP21C	—	—	—	—	—	—	—
0.8	23.0	700	1.03	.88	TP23	PC51H230	1.05	.88	TP23C	1.08	.88	TP23G	1.30	1.02	TP23GA	PC52H230
0.8	30.0	650	1.61	1.38	TP30	PC41H300**	1.64	1.38	TP30C	1.67	1.38	TP30G	1.92	1.47	TP30GA	PC42H300**
0.8	38.0	700	1.61	1.38	TP38	PC51H380	1.64	1.38	TP38C	1.67	1.38	TP38G	1.89	1.47	TP38GA	PC52H380

## Glass Embedded Band

Capacitance Range (pF)		Q (Min.)	Unsealed 1,000 DCWV (Fig. 1)			Sealed, Metal Cap, Turret Terminal 1,000 DCWV (Fig. 4)			Sealed, Metal Cap, 1,000 DCWV Larger MIL Size (Fig. 4)				
From Below	To Above		1 MHz	A±.03	B±.06	Type	A±.03	B±.06	Type	A±.03	B±.06	Type	MIL Designation
2.0	10.0	800	.28	.25	TP10*	.35	.33	TP10C*	—	—	—	—	
1.5	14.0	700	.39	.33	TP14	.45	.42	TP14C	.73	.69	TP14CA	—	
1.2	16.0	800	.33	.28	TP15*	.41	.39	TP15C*	—	—	—	—	
1.0	16.0	800	.39	.33	TP16	.45	.42	TP16C	.73	.69	TP16CA	PC43G160	
2.0	25.0	800	.44	.36	TP25	.50	.47	TP25C	—	—	—	—	
1.0	28.0	700	.63	.50	TP28	.70	.67	TP28C	.97	.92	TP28CA	—	
1.0	36.0	800	.63	.50	TP36	.70	.67	TP36C	.97	.92	TP36CA	PC43G360	
1.0	42.0	700	.84	.73	TP42	.91	.88	TP42C	1.19	1.14	TP42CA	—	
1.0	52.0	800	.84	.73	TP52	.91	.88	TP52C	1.19	1.14	TP52CA	PC43G520	
1.0	60.0	650	1.09	.91	TP60	1.16	1.13	TP60C	1.42	1.38	TP60CA	—	
1.0	75.0	700	1.09	.91	TP75	1.16	1.13	TP75C	1.42	1.38	TP75CA	PC43G750	
1.0	90.0	600	1.69	1.52	TP90	1.75	1.73	TP90C	2.03	1.98	TP90CA	—	
1.0	120.0	600	1.69	1.52	TP120	1.75	1.73	TP120C	2.03	1.98	TP120CA	PC43G121	
2.0	180.0	500	1.92	1.73	TP180*	1.98	1.95	TP180C*	—	—	—	—	

## Quartz

Capacitance Range (pF)		Q (Min.)	Unsealed 750 DCWV (Fig. 1)				Sealed, Quartz End, 1,250 DCWV (Fig. 3)						
From Below	To Above		1 MHz	A±.03	B±.03	Type	MIL Designation	Smaller (Fig. 3)			Larger MIL Size (Fig. 3)		
							A±.03	B±.03	Type	A±.03	B±.06	Type	MIL Designation
0.8	1.8	2000	.31	.25	QP2	PC41Q1R8	.38	.25	QP2G	.63	.50	QP2GA	PC42Q1R8
0.6	5.5	2000	.56	.44	QP6	PC41Q5R5	.64	.44	QP6G	.89	.70	QP6GA	PC42Q5R5
0.6	9.5	2000	1.00	.88	QP10	PC41Q9R5	1.09	.88	QP10G	1.33	1.02	QP10GA	PC42Q9R5
0.8	16.0	2000	1.61	1.38	QP16	PC41Q160	1.69	1.38	QP16G	1.92	1.47	QP16GA	PC42Q160

\*Parts Rated 500 DCWV

\*\*MIL-C-14409B parts not listed in MIL-C-14409D

# Differential Glass Trimmers

	Fig.	Capacitance Range (pF)				A	B	C
		Min. (1)	Min. (2)	Max. (1) (2)	Typical Crossover			
TM3D	1	1.5	2.0	3	2.4	.31	-	.09
TM8D	1	1.5	2.5	8	5.5	.55	-	.22
TM12D	1	1.5	3.0	12	7.7	.75	-	.31
TM16D	1	1.5	3.5	16	10.1	.94	-	.41
TM28D	1	1.5	5.0	26	16.0	1.44	-	.66
TP3D	2	1.5	2.0	3	2.4	.31	.28	.09
TP8D	2	1.5	2.5	8	5.5	.55	.45	.22
TP12D	2	1.5	3.0	12	7.7	.75	.61	.31
TP16D	2	1.5	3.5	16	10.1	.94	.75	.41
TP28D	2	1.5	5.0	26	16.0	1.44	1.13	.66

Note: For sealed versions, add "G" to part number, ie., TM8DG. The "A" dimension will be 0.11" longer.

For a differential trimmer capacitor, the capacitance of one element increases while the other element decreases, with the sum remaining approximately constant.

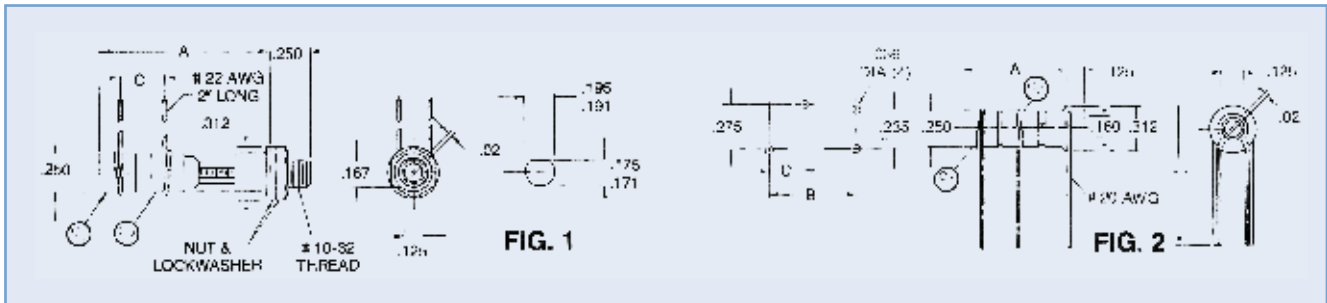
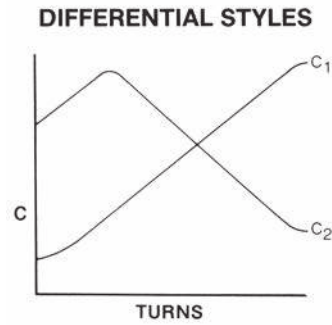

# Split Stator Glass Trimmers

	Fig.	Capacitance Range (pF)				A	B
		Plate/Plate		Plate/Brushing			
		Min.	Max.	Min.	Max.		
TM4S	1	0.8	2.0	0.8	4.2	.55	-
TM9S	1	1.5	4.5	0.8	9.0	1.02	-
TM14S	1	2.0	7.0	1.0	14.0	1.67	-
TP4S	2	0.8	2.0	0.8	4.2	.55	.47
TP9S	2	1.5	4.5	0.8	9.0	1.02	.91
TP14S	2	2.0	7.0	1.0	14.0	1.67	1.53

Note: For sealed versions, add "G" to part number, ie., TM4SG. The "A" dimension will be 0.11" longer.

Both elements of a split stator trimmer tune at approximately the same rate.

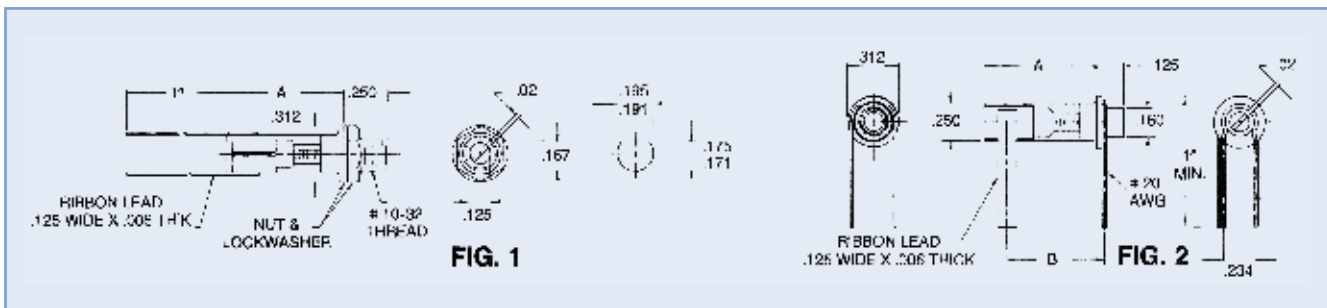
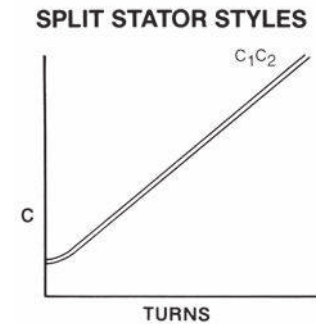

**General specifications on page 18 apply except:**

1. DC Working Voltage: 500
2. Temperature coefficient: 0±100 ppm/°C.

# Engineering Prototype Kits - Air/ PTFE/ Sapphire & Glass Trimmers

## Air Trimmers

"E" Series - Kit # 201			"K" Series - Kit # 204			"A" Series - Kit # 205			"KE" Series - Kit # 211		
Part No.	Qty.	Range	Part No.	Qty.	Range	Part No.	Qty.	Range	Part No.	Qty.	Range
ET10	3	0.8 - 10	KP8	3	0.6 - 8	AT10	3	1.0 - 10	KEP8	3	0.6 - 8
EP10	3	0.8 - 10	KP10	3	0.6 - 10	AP10	3	1.0 - 10	KEP10	3	0.6 - 10
EM10	3	0.8 - 10	KF8	3	0.6 - 8	AM10	3	1.0 - 10	KEF8	3	0.6 - 8
EF10	3	0.8 - 10	KF10	3	0.6 - 10	AF10	3	1.0 - 10	KEF10	3	0.6 - 10
ET14	4	0.8 - 14	KG8	2	0.6 - 8	AT14	4	1.0 - 14	KEG8	2	0.6 - 8
EP14	4	0.8 - 14	KG10	2	0.6 - 10	AP14	4	1.0 - 14	KEG10	2	0.6 - 10
EM14	4	0.8 - 14	KM8	2	0.6 - 8	AM14	4	1.0 - 14	KEM8	2	0.6 - 8
EF14	4	0.8 - 14	KM10	2	0.6 - 10	AF14	4	1.0 - 14	KEM10	2	0.6 - 10
TT-100	1	Tuning Tool	TT-100	1	Tuning Tool	TT-100	1	Tuning Tool	TT-100	1	Tuning Tool

## Glass Trimmers

"TM/ TP" Series - Kit # 206		
Part No.	Qty.	Range
TM36C	4	1 - 36
TM60C	4	1 - 60
TM120C	4	1 - 120
TM52C	4	1 - 52
TP75C	4	1 - 75
TP120C	4	1 - 120
TT-100	1	Tuning Tool

"H" Series - Kit # 207		
Part No.	Qty.	Range
HSP19	3	2 - 19
HSP34	3	2 - 34
HSP64	2	2 - 64
HSF19	3	2 - 19
HSF34	3	2 - 34
HSF64	2	2 - 64
TT-100	1	Tuning Tool

## Sapphire Trimmers

"P" Series - Kit # 209		
Part No.	Qty.	Range
P3B	2	0.6 - 2.5
P3F	3	0.6 - 2.5
P5B	2	0.6 - 4.5
P5F	3	0.6 - 4.5
P8B	2	0.8 - 8.0
P8F	3	0.8 - 8.0
TT-100	1	Tuning Tool

## PTFE Trimmers

"A_" Series - Kit # 210			"A" Extended Range Kit # 213		
Part No.	Qty.	Range	Part No.	Qty.	Range
AJ10HV	3	1 - 10	AJ40HV	2	1.5 - 40
AT15HV	3	1 - 16	AT40HV	2	1.5 - 40
AP25HV	3	1 - 23	AP55HV	2	1.5 - 55
TT-100	1	Tuning Tool	TT-100	1	Tuning Tool

"A_SD" Series - Kit # 212			"A_HV" Series - Kit # 216		
Part No.	Qty.	Range	Part No.	Qty.	Range
AJ10SD	4	1 - 23	AJ10HV	2	1 - 10
AP25SD	4	1 - 23	AM15HV	2	1 - 16
AT25SD	4	1 - 23	AP25HV	2	1 - 23
TT-100	1	Tuning Tool	AT40HV	2	1.5 - 40
			AJ55HV	2	1.5 - 55
			TT-100	1	Tuning Tool

## Low Cost Trimmers

"A1" Series - Kit # 202			"A4" Series - Kit # 214		
Part No.	Qty.	Range	Part No.	Qty.	Range
A1J4	2	0.45 - 4	A4J3	3	0.45 - 3
A1M4	2	0.45 - 4	A4M3	3	0.45 - 3
A1P4	2	0.45 - 4	A4P3	3	0.45 - 3
A1T4	2	0.45 - 4	A4J5	3	0.6 - 5
A1J8	2	0.5 - 8	A4M5	3	0.6 - 5
A1M8	2	0.5 - 8	A4P5	3	0.6 - 5
A1P8	2	0.5 - 8	TT-400	1	Tuning Tool
A1T8	2	0.5 - 8			
A1J12	2	1 - 12			
A1M12	2	1 - 12			
A1P12	2	1 - 12			
TT-400	1	Tuning Tool			

"A2" Series - Kit # 215			"A3" Series - Kit # 208		
Part No.	Qty.	Range	Part No.	Qty.	Range
A2J1	7	0.3 - 1.2	A3F10	4	1 - 10
A2M1	7	0.3 - 1.2	A3J10	4	1 - 10
A2P1	7	0.3 - 1.2	A3M10	4	1 - 10
TT-400	1	Tuning Tool	A3P10	4	1 - 10
			A3T10	4	1 - 10
			TT-400	1	Tuning Tool

## Pre-Set Trimmers

Every trimmer in this catalog can be set at a fixed value by Voltronics. This saves you the labor of setting the trimmer and can replace a fixed capacitor. If any part of the circuit drifts with temperature or time, the trimmer can be tuned. This will save not only initial set-up time, but will allow tuning without changing fixed components.

Voltronics trimmers are as stable as fixed capacitors and many are less expensive!

## Tuning Tools

MATAL (Fig.1)			
Part No.	Tip A	Tip B	Capacitor Series
TT-100	.110X.018	.070X.012	A, E, K, KE, DRO, Glass, NT P
TT-200	.110X.018	.032X.088	A, E, K, KE, DRO, Glass, NT
TT-300	.060X.018	.070X.012	A1, A3 P
TT-400	.060X.018	.036X.012	A1, A3 A2, A4



Ceramic (Fig.2)		
Part No.	Tip A	Capacitor Series
TT-500	.07X.016	A1, A3, A, E, K, KE, DRO
TT-600	.10X.016	Glass, NT
TT-700	.050X.016	P
TT-900	.038X.016	A2, A4

The TT-500 thru TT-900 tuning tools are ideal for continual use. They fit into the hand with the rotatable top fixed in the palm. The tips are made of high strength ceramic. Use these tools where metal tips affect tuning.

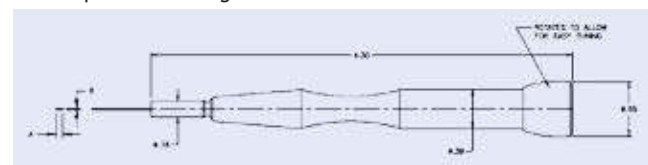



# DRO - Microwave Tuners For Dielectric Resonator



These precise tuners provide fine, stable adjustments to microwave components such as cavities, DRO's, wave guides and filters. Applications as diverse as space telemetry to supermarket door openers use these products. The self-locking slots in the threads together with the fine pitch provide reliable, permanent settings. They eliminate the loose fits and low resolution of standard threads. Tuning is smooth with controlled torque and no noise. Bushings, rotors and dielectric rods may be purchased separately. The DRO tuners are sealed either with an O-ring or by a true hermetic solder seal. The many versions of screw tuners are either entirely metallic or with dielectric rods of sapphire, alumina or quartz.

## Tuning Element Taps

Fluted taps are offered for each part because the thread sizes are fine and non-standard.

Selection Guide	
Style	Designation
DRO tuners	D & DK
DRO hermetically sealed tuners	D-HS
Metallic tuning elements	MT
Metallic rotors	MR
Dielectric tuning elements	DT
Dielectric rotors	DR
LC tuning elements	LCT
Tuning element Taps	VT

Part No.	Thread Size	For Series
VT-0	1.7mm-0.2mm	DR067
VT-1	.094-80	MR094, MT067
VT-2	.120-80	MT094
VT-3	.156-64	MR156, V7119
VT-4	.190-64	MT156, MR190, DR190, DK1A
VT-5	.234-65	MT190, MT190, D1A, D1AHS
VT-6	.250-64	LCT-1, LCT-2

## Dro Tuners

The Voltronics DRO Tuner design is based upon the proven tuning mechanisms of its trimmer capacitors. The parts have O-ring sealed front ends, long life, positive stops and low loss. The tuners have up to 10 full turns of resolution. The disk diameter ("A" Dim.) can be modified to meet your requirements. The hermetically sealed parts have high temperature solder joints. When soldered into your case, there is a hermetic barrier to the inside of your cavity. The part's O-ring seal keeps moisture and other contaminants from getting inside the tuner.

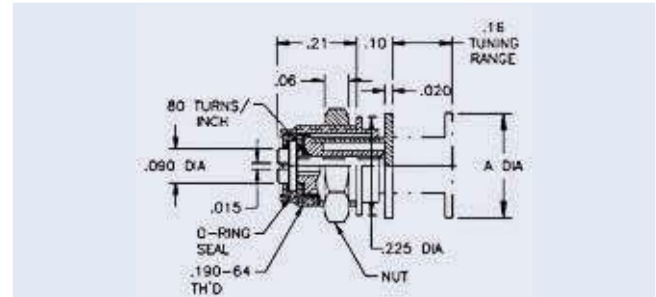
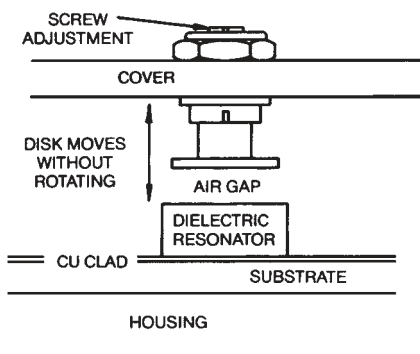

Part No.	A	B	C	D	E	F
DK1A15	.15	.225	.190-64	.015	.090	80
DK1A20	.20	.225	.190-64	.015	.090	80
DK1A25	.25	.225	.190-64	.015	.090	80
DK1A30	.30	.225	.190-64	.015	.090	80
D1A15	.168	.280	.234-64	.020	.110	64
D1A20	.20	.280	.234-64	.020	.110	64
D1A25	.25	.280	.234-64	.020	.110	64
D1A30	.30	.280	.234-64	.020	.110	64
D1A35	.35	.280	.234-64	.020	.110	64
D1A63	.63	.280	.234-64	.020	.110	64

## Hermetically Sealed DRO Tuners

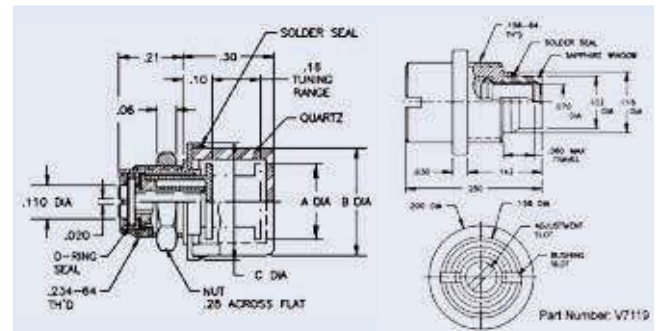

Part No.	A	B	C
D1A15HS	.150	.275	.306
D1A20HS	.200	.315	.345
D1A25HS	.250	.354	.385
D1A50HS	.500	.610	.640

## New Designs

Voltronics continues to develop new products for microwave tuning. Sizes and materials can be modified on most of the parts shown here. Call the factory with your requirements.

Note: Drawing tolerances where not specified XXX ± .005 XX ± .016

# Precision Microwave Cavity Tuners

## Metallic Tuning Elements

Part No.	A	B	C	D	E	F	Thread UNS-2
MT067-1*	0.145	-	0.114	-	0.054	0.060	.094-80
MT094-1	0.120	0.035	0.156	0.135	0.072	0.030	.120-80
MT094-2	0.120	0.035	0.156	0.135	0.072	0.075	.120-80
MT094-3	0.240	0.035	0.156	0.135	0.072	0.075	.120-80
MT094-4	0.240	0.035	0.156	0.135	0.072	0.148	.120-80
MT156-1	0.125	0.037	0.220	0.210	0.125	0.023	.190-64
MT156-2	0.250	0.037	0.220	0.210	0.125	0.148	.190-64
MT190-1	0.130	0.035	0.280	0.267	0.160	0.025	.234-64
MT190-2	0.187	0.031	0.280	0.267	0.160	0.106	.234-64
MT190-3	0.210	0.035	0.280	0.267	0.160	0.106	.234-64
MT190-4	0.210	0.035	0.280	0.267	0.160	0.180	.234-64
MT190-5	0.360	0.145	0.280	0.267	0.160	0.255	.234-64
MT190-6	0.450	0.240	0.280	0.267	0.160	0.340	.234-64

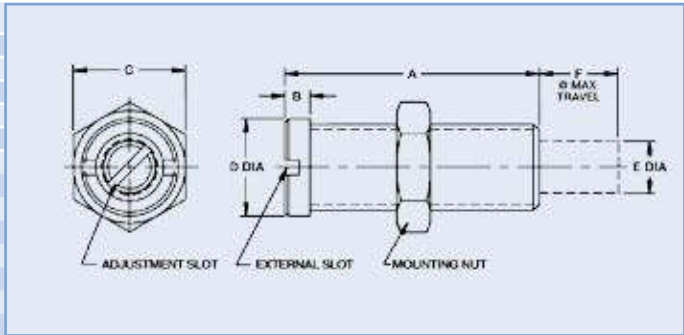

\*Nut is .114 diameter by .070 thick and threaded bushing is slotted.

## Metallic Rotors

Part No.	A	B	C	Thread UNS-2
MR094-1	0.122	0.030	0.072	.094-80
MR094-2	0.167	0.075	0.072	.094-80
MR094-3	0.240	0.148	0.072	.094-80
MR156-1	0.125	0.023	0.125	.156-64
MR156-2	0.250	0.148	0.125	.156-64
MR190-1	0.210	0.106	0.160	.190-64
MR190-2	0.359	0.255	0.160	.190-64
MR190-3	0.449	0.345	0.160	.190-64
MR190-4	0.554	0.450	0.160	.190-64

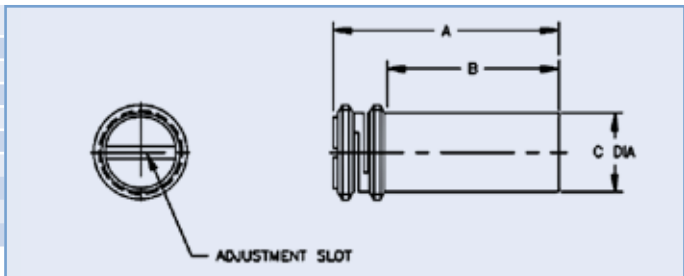

## LC Tuning Elements

Part No.	A	B	C	D	E	F	G	H	Thread UNS-2
LCT-1	0.700	0.047	0.145	0.281	0.160	0.210	0.250	0.232	.250-64
LCT-2	1.000	0.047	0.145	0.281	0.160	0.210	0.375	0.232	.250-64

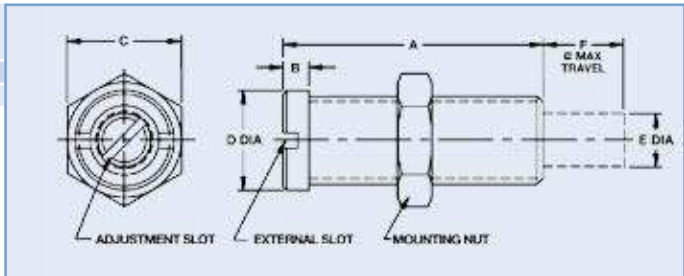

## Dielectric Tuning Elements

Part No.	A	B	C	D	E	F	G	Thread UNS-2	Material
DT190-1	0.210	0.035	0.280	0.267	0.152	0.106	0.009	.234-64	Sapphire
DT190-2	0.359	0.144	0.280	0.267	0.152	0.010	0.010	.234-64	Sapphire
DT190-3	0.359	0.144	0.280	0.267	0.152	0.270	0.270	.234-64	Alumina

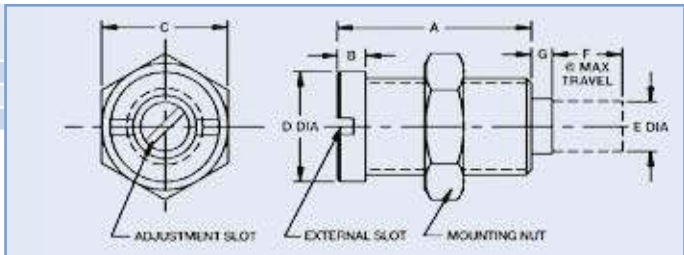

## Dielectric Rotors

Part No.	A	B	C	Thread UNS-2	Material
DR067-1	0.494	0.394	0.03	1.7mm-0.2mm*	Sapphire
DR067-2	0.494	0.394	0.03	1.7mm-0.2mm*	Alumina
DR067-3	0.494	0.394	0.03	1.7mm-0.2mm*	Quartz
DR190-1	0.369	0.195	0.062	.190-64	Alumina
DR190-2	0.674	0.5	0.062	.190-64	Alumina
DR190-3	0.874	0.7	0.062	.190-64	Sapphire
DR190-4	0.375	0.22	0.152	.190-64	Alumina
DR190-5	0.439	0.3	0.152	.190-64	Alumina
DR190-6	0.503	0.345	0.152	.190-64	Alumina
DR190-7	0.567	0.42	0.152	.190-64	Alumina
DR190-8	0.649	0.495	0.152	.190-64	Alumina
DR190-9	0.904	0.75	0.152	.190-64	Alumina

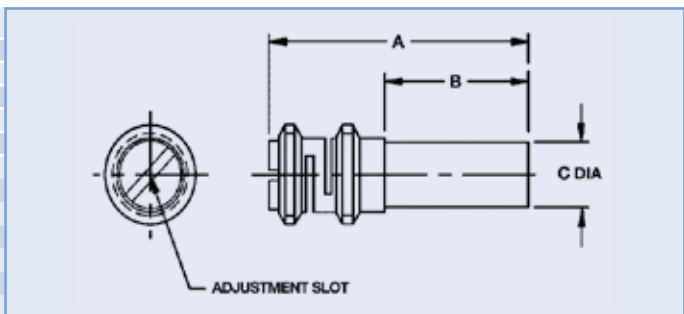

\*Threads are metric.













# Product Guide - Non Magnetic Trimmers

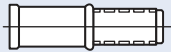

Increasing magnetic resonance applications caused Voltronics to launch an active engineering effort in this field years ago, one that continues today. Due to the severe non-magnetism requirements in these industries, we use only materials that exhibit no measurable magnetism. Commercial brass and plating materials are not acceptable. Our strict traceability and testing regimes insure this essential parameter.

Most of our trimmers are internally sealed so that they withstand immersion in flux and solvents without leaking. Most of our non-magnetic trimmers have been used and tuned at temperatures as low as 4K. Many of our selection of trimmers have been developed for specific customer needs – let us design a high performance trimmer for your application.

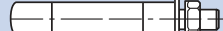
## Product Selection Guide - Consult Factory for Complete Catalog

Product Line	Description	Series	Maximum Capacitance	Maximum DC Working Voltage	Typical minimum Q value
A1_4/8  A1_12 	Miniature PTFE Dielectric	A4_HV	12pF	1000	2000 - 4000
A4_3  A4_5 		A1_HV	5pF	1000	2000 - 3000
A_HV 	High Voltage PTFE Dielectric	A_HV	30pF	1000	2000
A_HV Ext Range 		A_HV	55pF ext. range	1000	780 - 2000
K_HV 		K_HV	15pF	1000	780 - 2000
NT  Minimum	20kV PTFE Dielectric	NT	95pF	10000	2000
GLASS  Minimum	Glass Dielectric	HTM TF TM TP	250pF 36pF 130pF 180pF	1250 1000 1250 1250	250 - 1000
QUARTZ  Maximum	Quartz Dielectric	QM	24pF	1250	2000
P8  P40 	Sapphire Dielectric	P	40pF	500	1500 - 4000
V9000 		V9000	12pF	2000	3000

# NT Series - Non Magnetic PTFE Trimmer Capacitors



## 4kV to 20kV

### High Voltage Applications

Voltronics new "NT" series of PTFE trimmers are designed for applications requiring greater capacitance and voltage ratings than the popular smaller trimmers but without the large size and expense of vacuum capacitors.

#### Other features include:

- High voltage
- Non-rotating piston, long life & no tuning noise
- Extremely stable under shock & vibration
- Screw head does not move in and out

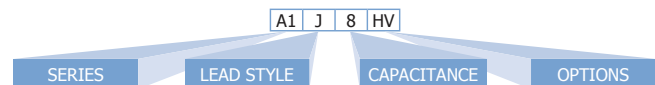
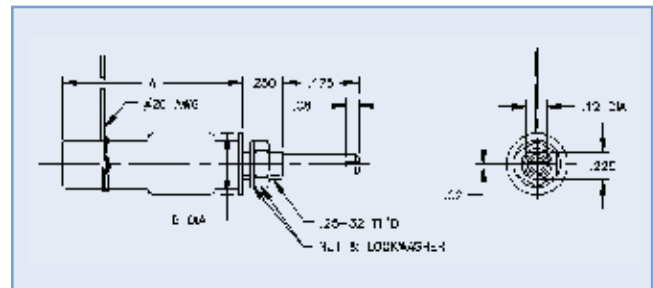

Part No.	DC Working Voltage	DC Withstanding Voltage	Capacitance (pF) <	Capacitance (pF) >	A" Dim ± .06	'B" Dim ± .06
NMNT2-20	20000	10000	1	2	1.205	1.125
NMNT5-18	8750	17500	1	5	2	0.75
NMNT10-6	3000	6000	1	10	1.15	0.38
NMNT10-12	6000	12000	2	10	1.83	0.063
NMNT15	4000	8000	1	15	1.69	0.31
NMNT25-6	3000	6000	5	25	1.62	0.063
NMNT25-15	6000	12000	7	25	1.77	1.13
NMNT30	5000	10000	4	30	2.25	1.5
NMNT50	4500	9000	5	50	2.25	1.5
NMNT70-6	3000	6000	2.5	70	3	0.7
NMNT70-15	7500	15000	6.5	70	3.25	1.63
NMNT85	3000	6000	5	85	3.25	1.5
NMNT100-4	2500	3600	2	95	4.25	0.31
NMAJ0.5	2000	4000	0.8	10	1	0.3
NMA 20.5	2000	4000	0.8	20	1	0.3

# V9000 - Non Magnetic PTFE Trimmer Capacitor



The V9000 trimmer capacitor is a unique design: truly sub miniature at just 0.64" in length, but offers the highest working voltage rating, of 2kV and capacitance value, up to 12pF, available in its size. Using a Sapphire dielectric, for its ideal dielectric constant, it is extremely stable, is chemically inert, moisture resistant and mechanically strong. Recently launched, additional features are still under development, contact Voltronics for our usual custom modifications and adaptations.

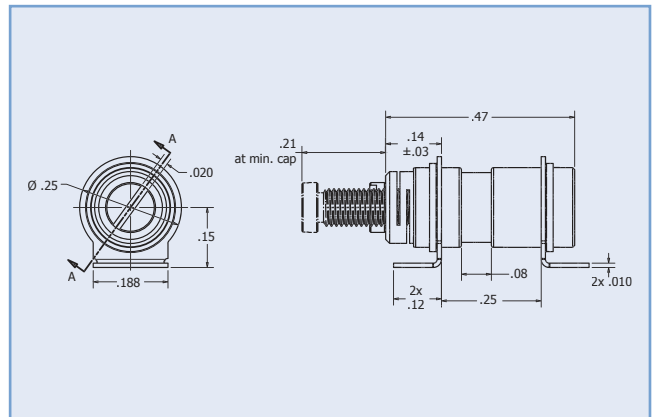

## General Specifications

Capacitance Range	1.0pF to 12.0pF Typical
DC Working Voltage @ 12.0pF	2000V
DC Withstanding Voltage @ 12.0 pF	3000V
Q Factor @ 100MHz & 12.0 pF	3000 Min
Insulation Resistance	105 MΩ @ 25°C
Temperature Coefficient	500 ± 200 ppm/°C

## Mechanical Specifications

Tuning Torque	0.5 in oz to 3.0 in oz
Rotational Life	600 Turns Min
Construction	Non-Magnetic

## Environmental

Operating Temperature	-55°C to +125°C
RoHS Compliant	

## Solder Pad Layout

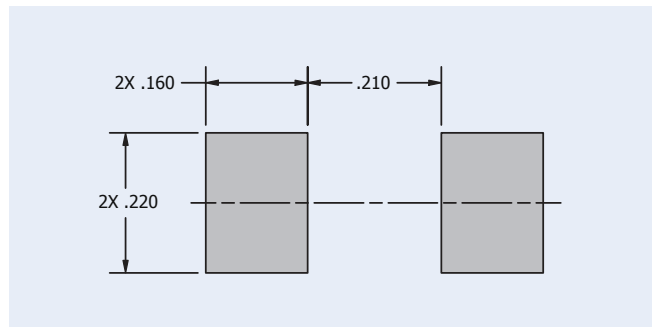

Part No.	DC Working Voltage	DC Withstanding Voltage	Capacitance (pF) <	Capacitance (pF) >
V9000	2000V	3000V	1	12

# Product Guide - Non Magnetic High Q Multilayer Capacitors



Made from highly stable, low loss dielectric formulations, these traditional porcelain MLCs are known for their high RF power handling capability. Available in all industry common case sizes. The special silver-palladium termination and the proprietary ceramic formulations guarantee consistent non-magnetic performance. All MLCs in these series are RoHS compliant. Chips are available either with standard termination or can be fitted with ribbon leads, depending on your application.

## Description

- Porcelain Capacitors • Zero TC • Low Noise • Low ESR, High Q
- High Self-resonance • Established Reliability
- Capacitance range 0.1-5100 pF

## Functional Applications

- Impedance Matching • DC Blocking • Bypass • Coupling
- Tuning & Feedback

Case Size Series	Dimensions inches	Working Voltage Range, Volts DC	Capacitance Range, pF
5	0.055" x 0.055"	Up to 250V	0.1 to 100
11	0.110" x 0.110"	Up to 1000V	0.1 to 1000
25	0.220" x 0.250"	Up to 2500V	1.0 to 2700
38	0.380" x 0.380"	Up to 7200V	1.0 to 5100

## Electrical Specifications

Dissipation Factor	0.05% @ 1 MHz max.
Dielectric Withstanding Voltage	250% of rated WVDC for 5 sec. Unless specified in chart
Insulation Resistance	@ 25°C 10 <sup>6</sup> M  min. @ 125°C 10 <sup>5</sup> M  min
Aging	None
Piezoeffects	None
Dielectric Absorption	None

## Packaging

Style	Package	Option
5 Series	Bulk in plastic bags	Tape & Reel - 3,500 pcs.
11 Series	Bulk in plastic bags	Tape & Reel - 2,350 pcs.
25 Series	Bulk in plastic bags	Tape & Reel - 500 pcs.
38 Series	Bulk in plastic bags	Tape & Reel - 250 pcs.

## Part Numbering System

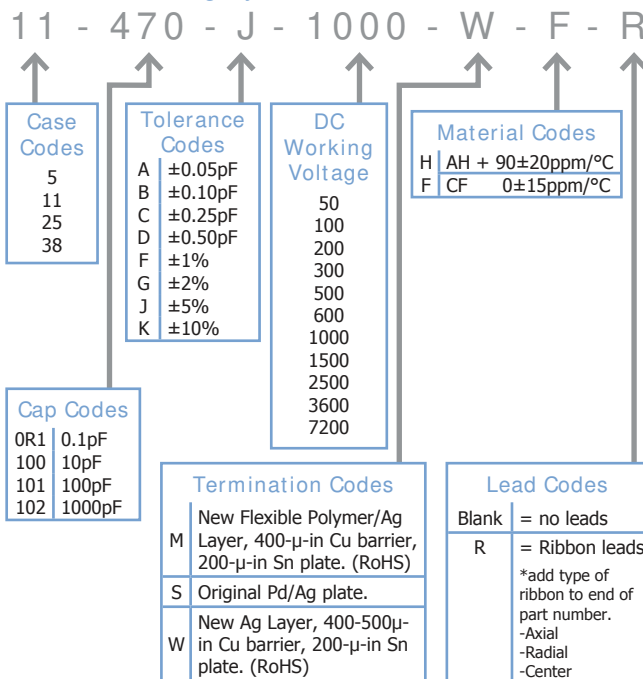

Cap Code	Cap (PF)	5 Series 0505	11 Series 1111	25 Series 2225	38 Series 3838
OR1 to 1R0	0.1 to 1	} 0.1pF increments	250V	1000V	7200V
1R0 to 2R0	1 to 2				
2R1	2.1				
2R2	2.2				
2R4	2.4				
2R7	2.7				
3R0	3				
3R3	3.3				
3R6	3.6				
3R9	3.9				
4R3	4.3	200V	2500V	DWV = 3000V	DWV = 8700V
4R7	4.7				
5R1	5.1				
5R6	5.6				
6R2	6.2				
6R8	6.8				
7R5	7.5				
8R2	8.2				
9R1	9.1				
100	10				
110	11				
120	12				
130	13				
150	15				
160	16				
180	18				
200	20				
220	22				
240	24				
270	27				
300	30				
330	33				
360	36				
390	39				
430	43				
470	47				
510	51				
560	56				
620	62				
680	68				
750	75				
820	82				
910	91				
101	100				
111	110				
121	120				
131	130				
151	150				
161	160				
181	180				
201	200				
221	220				
241	240				
271	270				
301	300				
331	330				
361	360				
391	390				
431	430				
471	470				
511	510				
561	560				
621	620				
681	680				
751	750				
821	820				
911	910				
102	1000				
122	1200				
152	1500				
182	1800				
222	2200				
272	2700				
332	3300				
392	3900				
472	4700				
512	5100				
Reel QTY		3500	2350	500	250



# Non Magnetic High Q Multilayer Capacitors

## Recommended Procedure for Hand Soldering Chip Capacitors

Equipment: Weller Ec-2001 soldering system (42 watt) or equivalent (1/8" tip) for 11 Series, (1/4" tip) for 25 Series or (3/8" tip) for 38 Series  
310 ± 10 degrees C tip temperature

Solder: Sn60/Sn62/Sn36

Flux: Alpha 611 type RMA or equivalent

Cleaning Solvents: 2-propanol or commercial defluxing solvent

Procedure:

1. Preheat chip and stripline to 100-120°C for a minimum of one minute. If solder other than the above is used, preheat to within 50-70°C of reflow temperature.
2. Dip chip in flux for 2-3 seconds, or apply flux to chip and stripline area. Apply solder paste if necessary.
3. Place iron on stripline for three seconds to preheat, then move slowly to contact chip for approximately four seconds to effect reflow.
4. When reflow is achieved, withdraw iron slowly, allow to cool naturally.
5. Clean area thoroughly, with 2-propanol or other defluxing solvent. If possible, use ultrasonic cleaning for these steps.
6. Inspect solder fillet for coverage and defects.

## Termination Guide

New (RoHS)	- "M"	Flexible polymer / Ag layer, 400-500µ-in Cu barrier, 200µ-in Sn plate.
New	- "R"	Ag layer, 400-500µ-in Cu barrier, 10,000-1 2,000µ-in 90/10 Sn/Pb plate
Original	- "S"	PdAg plate
New	- "V"	Ag layer, 400-500µ-in Cu barrier, 100-150µ-in 90/10 Sn/Pb plate
New (RoHS)	- "W"	Ag layer, 400-500µ-in Cu barrier, 200µ-in Sn plate

MATERIAL GUIDE/Temp. coefficient

"AH" +90 ± 20ppm/ °C

"CF" 0 ± 15ppm/ °C

Lower ESR

"UL" 0 ± 30ppm/ °C

## Recommended Solder Reflow Profile

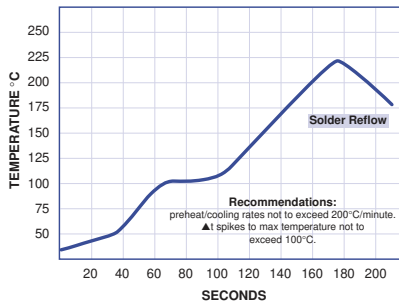

## Solder Pad Layout & Dimensions

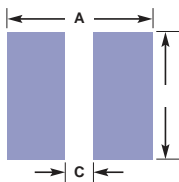

Case Style	Internal Electrode Orientation	Reflow Soldering			Wave Soldering		
		A	B	C	A	B	C
5 Series	Horizontal	.100	.075	.020	.130	.075	.020
11 Series	Horizontal	.160	.135	.050	.190	.135	.050
11 Series	Vertical	.160	.110	.050	.190	.110	.050
25 Series	Horizontal	.270	.275	.110	.300	.275	.110
38 Series	Horizontal	.425	.400	.290	.455	.400	.290

## Electrical Parameters

Quality Factor	Exceeds MIL-C- 55681	
Resonant Frequency	Exceeds MIL-C- 55681	
Max. Dissipation Factor	.05% at 1 MHz	
Insulation Resistance		
Capacitance Range	+ 25 °C	+ 125 °C
0.1-470pF	>10 <sup>6</sup> megohms	>10 <sup>5</sup> megohms
510-5100pF	>10 <sup>5</sup> megohms	>10 <sup>4</sup> megohms
Dielectric Withstanding Voltage	Capable of withstanding 2.5 x Rated Voltage	
Capacitance Drift	±0.2% or .0 pF, whichever is greater	
Aging Effect	None	
Piezoelectric Effect	None	
Dielectric Absorption	None	

## Mechanical & Environmental Parameters

Parameters	MIL-STD-202-	
	Method	Condition
Thermal Shock	107	A
Immersion	104	B
Moisture Resistance	106	-
Solderability	208	-
Resistance to Solder Heat	210	C
Burn In	108	A
Barometric Pressure	105	B
Shock	213	I
Vibration	204	A
Terminal Strength	211	A

	Nail Head	Ribbon Lead
Series 11>	10lbs. min.	5lbs. min.
Series 25>	10lbs. min.	10lbs. min.
Series 38>	20lbs. min.	20lbs. min.

The quality system is approved to MIL-I-45208 & 10001. All parts are 100% thermal stress tested.

## Attachment Methods

All parts are constructed to be compatible with commonly used industry methods. Reflow soldering, wave soldering, vapor phase soldering ("S" termination) and conductive epoxy ("R" termination) may be used.

## Cleaning

Chip capacitors can withstand commonly used cleaning agents such as water, alcohol, and degreaser solvents. Ascertain that no flux residues are left on the chip surfaces and no flux is trapped under the chip. Flux residue will degrade Q, insulation resistance and reliability.

## Shelf Life

Capacitors will be solderable for a minimum of one year from date of shipment if properly stored in the original packaging. Dry nitrogen storage is preferable for longer periods.

## Precautions

The rate of heating and cooling must be controlled to preclude thermal cracking of the devices. Processes, heating or cooling, should not exceed a rate of 20000 per minute. Spikes must not exceed 100°C maximum for any solder operation. Avoid forced cooling or contact with heat sinks, such as conveyor belts, metal tables or cleaning solutions, before the chips reach ambient temperatures.

## Why Rounded Corners?

Rounded corners provide uniform termination on these MLC products. The greater surface area improves solder attachment and provides a more uniform adhesion to the board. Rounded corners also reduce the chance of tomb-stoning and mechanical thermal shock types of stress.



# 5 Series - Non Magnetic High Q Multilayer Capacitors



General Specifications	
Case Size	.055" L x .055" W x .050" H
Capacitance Range	0.1pF to 100pF
DC Working Voltage	250 0.1 to 33pF 200 36 to 100pF
DC Withstanding Voltage	2.5 x Working Voltage
Quality Factor Temperature	See chart below
Coefficient Operating	0 ±15ppm/°C
Temperature Insulation	-55°C to +175°C
Resistance @ 25°C	10 <sup>6</sup> megohms

## Dimensions

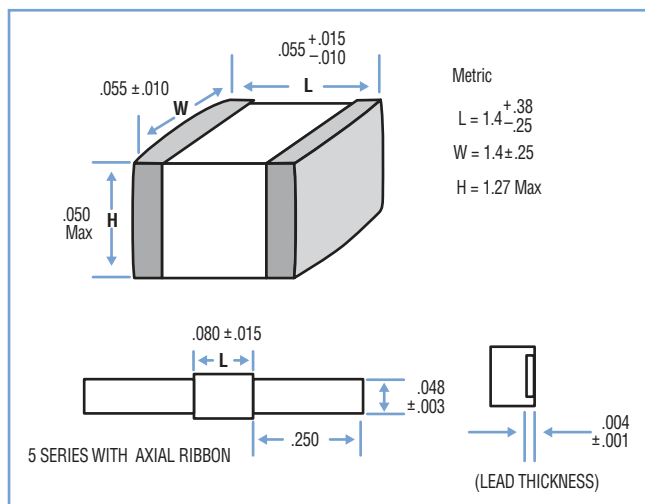

## Capacitance Values

Capacitance (pF)	Capacitance Code	Tolerance	Working Voltage
0.1	OR1	B	250
0.2	OR2	A,B	
0.3	OR3	A,B,C	
0.4	OR4	A,B,C,D	
0.5	OR5		
0.6	OR6		
0.7	OR7		
0.8	OR8		
0.9	OR9		
1	1R0		
1.1	1R1		
1.2	1R2		
1.3	1R3		
1.4	1R4		
1.5	1R5	B,C,D	
1.6	1R6		
1.7	1R7		
1.8	1R8		
1.9	1R9		
2	2R0		
2.1	2R1		
2.2	2R2		
2.4	2R4		
2.7	2R7		
3	3R0		
3.3	3R3		
3.6	3R6		
3.9	3R9		
4.3	4R3		
4.7	4R7		
5.1	5R1		
5.6	5R6		
6.2	6R2		
6.8	6R8		
7.5	7R5		
8.2	8R2		
9.1	9R1		
10	100	F,G,J,K	
11	110		
12	120		
13	130		
15	150		
16	160		
18	180		
20	200		
22	220		
24	240		
27	270		
30	300		
33	330		
36	360		
39	390		
43	430		
47	470		
51	510		
56	560		
62	620		
68	680		
75	750		
82	820		
91	910		
100	101		
		200	

## Quality Factor (Q)

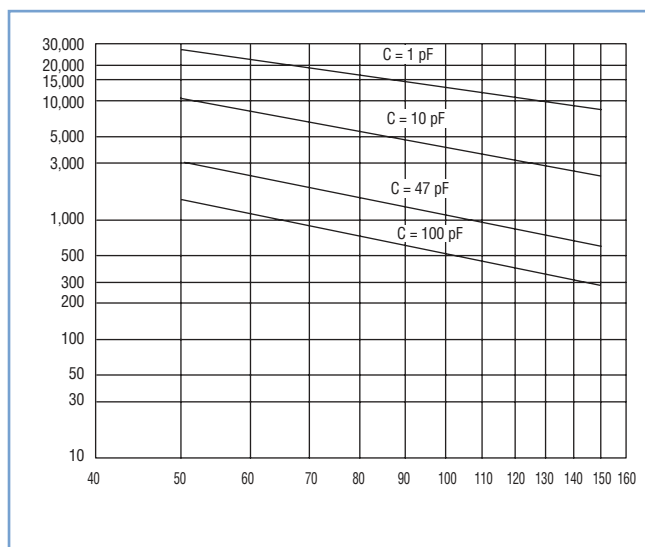

Note: For a detailed Q chart go to [www.voltronicscorp.com](http://www.voltronicscorp.com)

# 11 Series - Non Magnetic High Q Multilayer Capacitors



General Specifications	
Case Size	.110" L x .110" W x .100" H
Capacitance Range	0.1pF to 1,000pF
DC Working Voltage	1,000 0.1 to 100pF
	600 110 to 200pF
	200 220 to 470pF
	100 510 to 620pF
	50 680 to 1,000pF
DC Withstanding Voltage	2.5 x Working Voltage
Quality Factor	See chart below
Temperature Coefficient	+90 $\pm$ 20ppm/ $^{\circ}$ C
	0 $\pm$ 15ppm/ $^{\circ}$ C
Operating Temperature	-55 $^{\circ}$ C to +175 $^{\circ}$ C
Insulation Resistance @ 25 $^{\circ}$ C	0.1 to 470pF 10 <sup>6</sup> megohms
	510 to 1,000pF 10 <sup>5</sup> megohms

## Dimensions

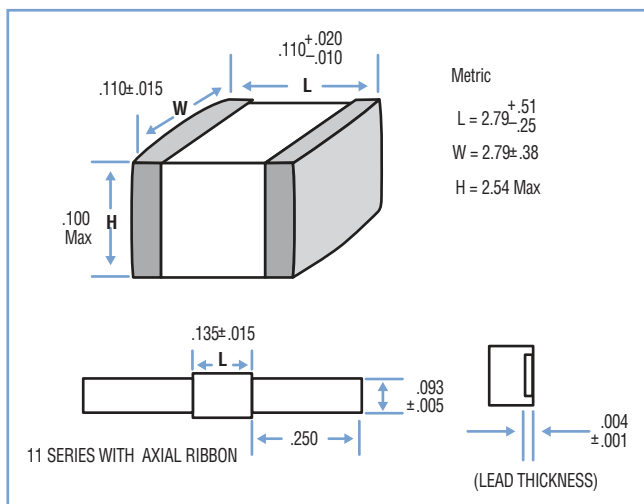

## Quality Factor (Q)

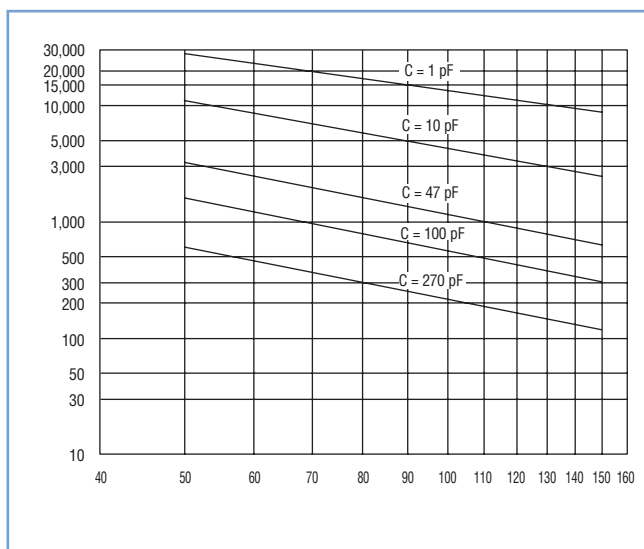

Note: For a detailed Q chart go to [www.voltronicscorp.com](http://www.voltronicscorp.com)

## Capacitance Values

Capacitance (pF)	Capacitance Code	Tolerance	Working Voltage
0.1	0R1	A,B	1,000
0.2	0R2		
0.25	0R25		
0.3	0R3	A,B,C	
0.4	0R4		
0.45	0R45		
0.5	0R5		
0.6	0R6	A,B,C,D	
0.7	0R7		
0.8	0R8		
0.9	0R9		
1	1R0		
1.1	1R1		
1.2	1R2		
1.3	1R3		
1.4	1R4		
1.5	1R5		
1.6	1R6		
1.7	1R7		
1.8	1R8		
1.9	1R9		
2	2R0	B,C,D	
2.1	2R1		
2.2	2R2		
2.4	2R4		
2.7	2R7		
3	3R0		
3.3	3R3		
3.6	3R6		
3.9	3R9		
4.3	4R3		
4.7	4R7		
5.1	5R1		
5.6	5R6		
6.2	6R2		
6.8	6R8		
7.5	7R5		
8.2	8R2		
9.1	9R1		
10	100	F,G,J,K	
11	110		
12	120		
13	130		
15	150		
16	160		
18	180		
20	200		
22	220		
24	240		
27	270		
30	300		
33	330		
36	360		
39	390		
43	430		
47	470		
51	510		
56	560		
62	620		
68	680		
75	750		
82	820		
91	910		
100	101	600	
110	111		
120	121		
150	151	200	
180	181		
200	201		
220	221	100	
270	271		
330	331		
390	391	50	
470	471		
510	511		
620	621		
680	681		
820	821		
1000	102		

# 25 Series - Non Magnetic High Q Multilayer Capacitors



General Specifications	
Case Size	.220" L x .250" W x .130" H
Capacitance Range	1pF to 2,700pF
DC Working Voltage	2,500 330 to 470pF 1,000 560 to 1200pF 500 1500 to 1800pF 300 2200 to 2700pF
DC Withstanding Voltage	2.5 x Working Voltage
Quality Factor	See chart below
Temperature Coefficient	0 ±15ppm/°C
Operating Temperature	-55°C to +125°C
Insulation Resistance @ 25°C	10 <sup>5</sup> megohms

## Dimensions

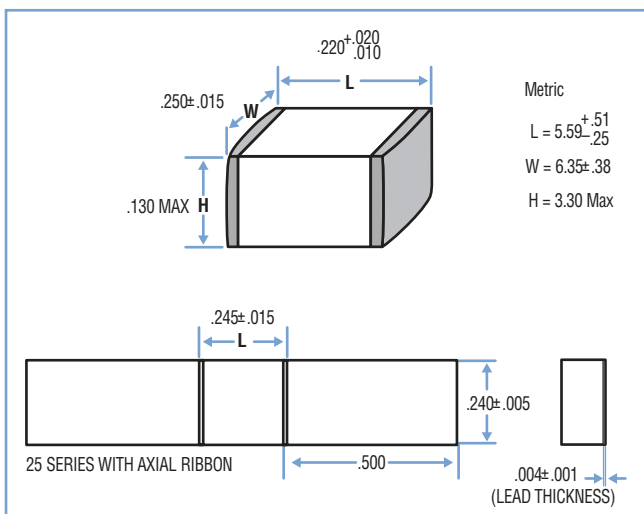

## Capacitance Values

Capacitance (pF)	Capacitance Code	Tolerance	Working Voltage
1	1R0	A,B,C	2,500
1.2	1R2	B,C	
1.5	1R5		
1.8	1R8		
2.2	2R2		
2.7	2R7		
3.3	3R3		
3.9	3R9		
4.7	4R7		
5.6	5R6		
6.8	6R8		
8.2	8R2		
10	100		
12	120		
15	150		
18	180		
22	220		
27	270		
33	330		
39	390		
47	470		
56	560		
68	680		
82	820		
100	101		
120	121		
150	151		
180	181		
220	221		
270	271		
330	331		
390	391		
470	471		
580	511		
680	681		
820	821		
1000	102		
1200	122		
1500	152		
1800	182		
2200	222		
2700	272		
		1,500	
		1,000	
		500	
		300	

## Quality Factor (Q)

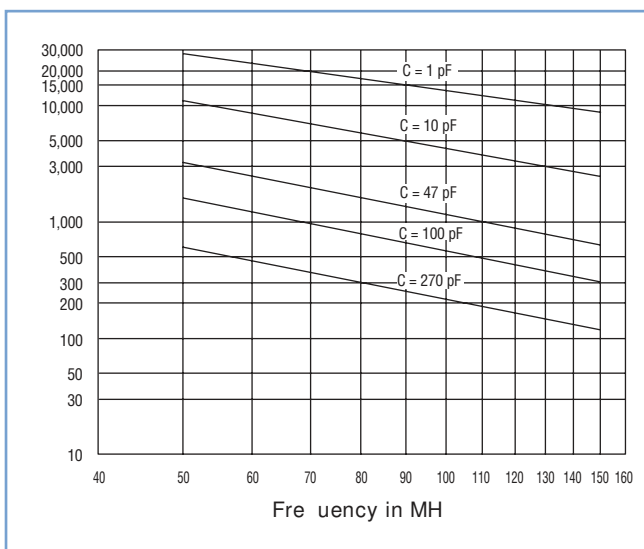

Note: For a detailed Q chart go to [www.voltronicscorp.com](http://www.voltronicscorp.com)

# 38 Series - Non Magnetic High Q Multilayer Capacitors



## Dimensions

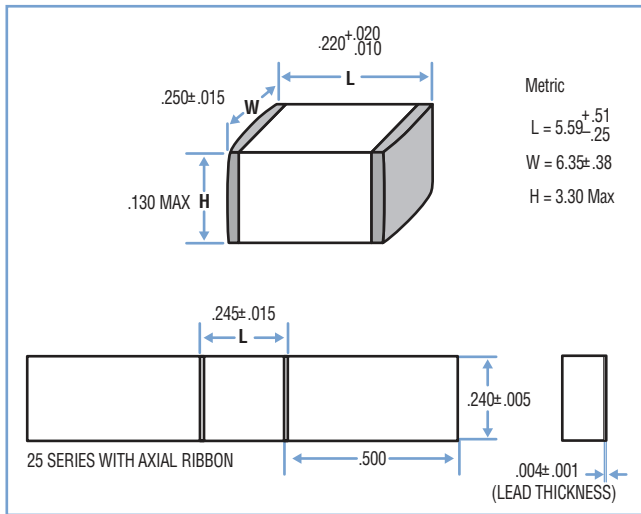

## Quality Factor (Q)

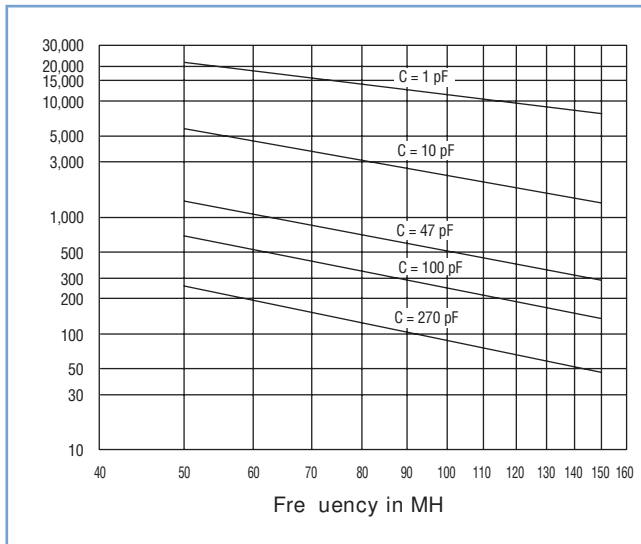

Note: For a detailed Q chart go to [www.voltronicscorp.com](http://www.voltronicscorp.com)

## General Specifications

Case Size	.380" L x .380" W x .130" H
Capacitance Range	1pF to 5,100pF
DC Working Voltage	7,200 1 to 100pF 3,600 120 to 390pF 2,500 470 to 680pF 1,000 820 to 2200pF 500 2700 to 5100pF
DC Withstanding Voltage	2.5 x Working Voltage
Quality Factor	See chart below
Temperature Coefficient	+90 $\pm$ 20ppm/ $^{\circ}$ C
Operating Temperature	-55 $^{\circ}$ C to +125 $^{\circ}$ C
Insulation Resistance @ 25 $^{\circ}$ C	10 <sup>5</sup> megohms

## Capacitance Values

Capacitance (pF)	Capacitance Code	Tolerance	Working Voltage
1	1R0	B,C	7,200
1.2	1R2		
1.5	1R5		
1.8	1R8		
2.2	2R2		
2.7	2R7		
3.3	3R3		
3.9	3R9		
4.7	4R7		
5.6	5R6		
6.8	6R8		
8.2	8R2		
10	100		
12	120		
15	150		
18	180		
22	220		
27	270		
33	330		
39	390		
47	470		
56	560		
68	680		
82	820		
100	101	G,J,K	3,600
120	121		
150	151		
180	181		
220	221		
270	271		
330	331		
390	391		
470	471		
580	511		
680	681		
820	821		
1000	102		
1200	122		
1500	152		
1800	182		
2200	222		
2700	272		
3300	332		
3900	392		
4700	472		
5100	512		
			2,500
			1,000
			500

# Product Guide - Non Magnetic Coils



To further support our magnetic resonance customers around the world, Voltronics supplies a comprehensive line of totally non-magnetic air coil inductors and potted inductors. In concert with our ISO9001 approved partner, Voltronics can also supply your BALanced UNbalanced transformer coil requirements. We understand that each application is unique. We ask that you provide us with your drawings or samples of your coils and we will provide a quote and samples in two weeks. When your application requires high performance non-magnetic components, think first of Voltronics.

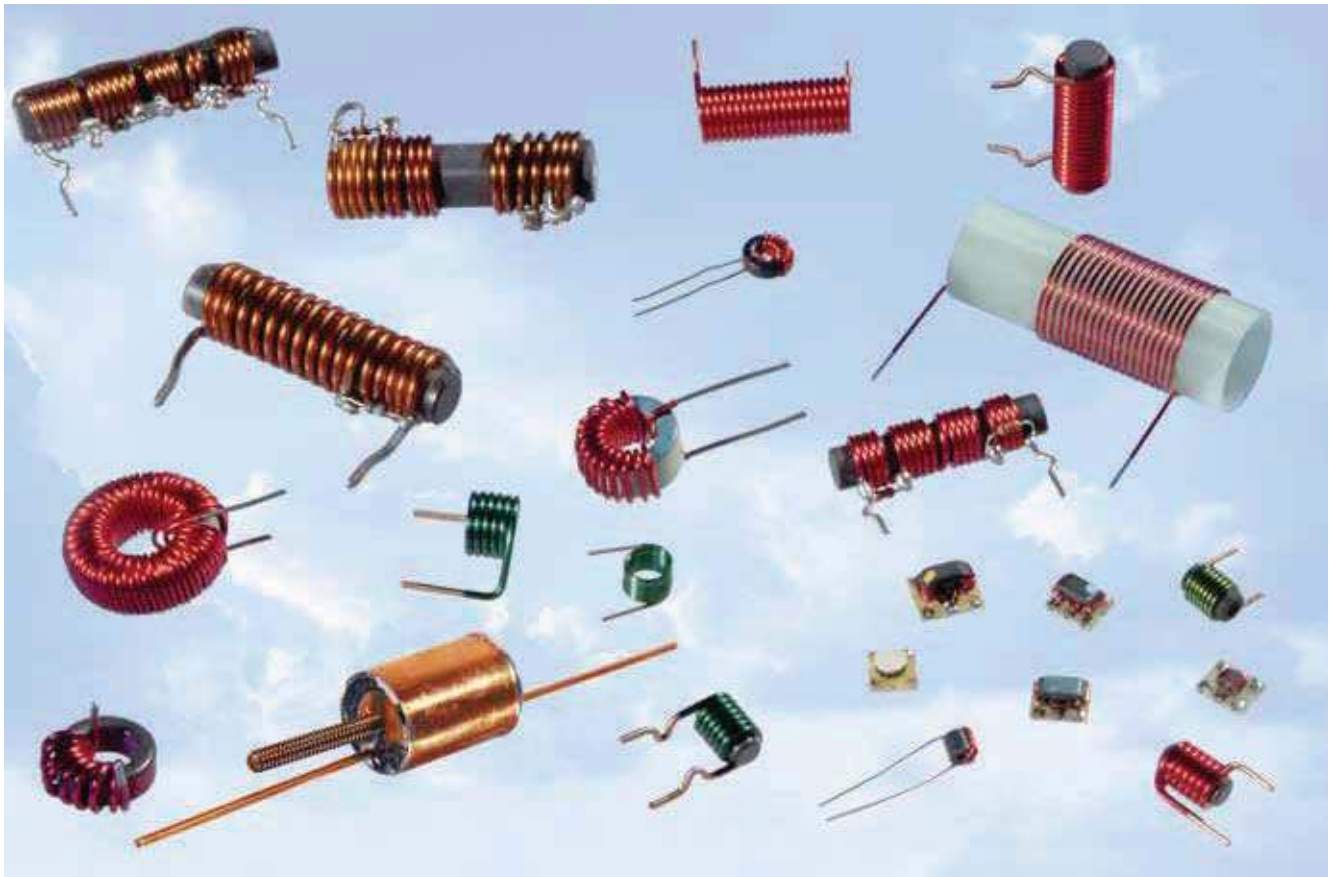

Consult Factory for Specific Requirements

# Non Magnetic Diodes

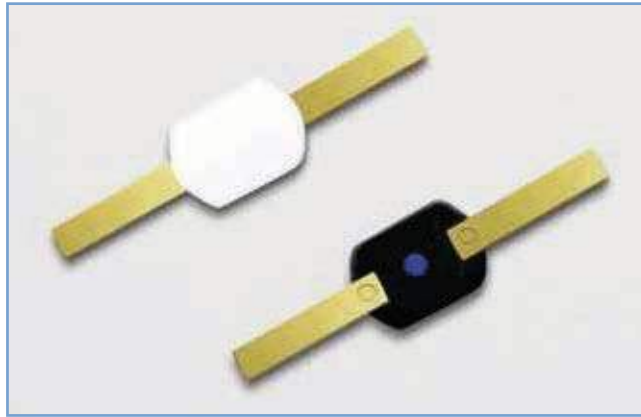

In support of our magnetic resonance customers around the world, Voltronics now offers a comprehensive line of non-magnetic diodes. With our ISO9001 approved partner, Voltronics wants to be your diode design partner for your future unique needs and your reliable supplier of your current requirements. Our comprehensive capabilities include PIN diodes, dual diodes, Schottky diodes, and more. When your application requires high performance non-magnetic components, think first of Voltronics.

## RF Actuated Diode Switch

The MX51363-145 is designed to be used as a surface coil blocking network. The part consists of four step recovery diodes, connected as two anti parallel pairs.

### Specifications:

Total junction capacitance plus package capacitance, measured with an RF source voltage less than or equal to 71 mV RMS at 50 MHz and no DC bias, shall not exceed 3.5pF.

Q equal to or greater than 1,000.

Thermal resistance not to exceed 60°C / Watt

Maximum junction operating temperature shall be 125°C

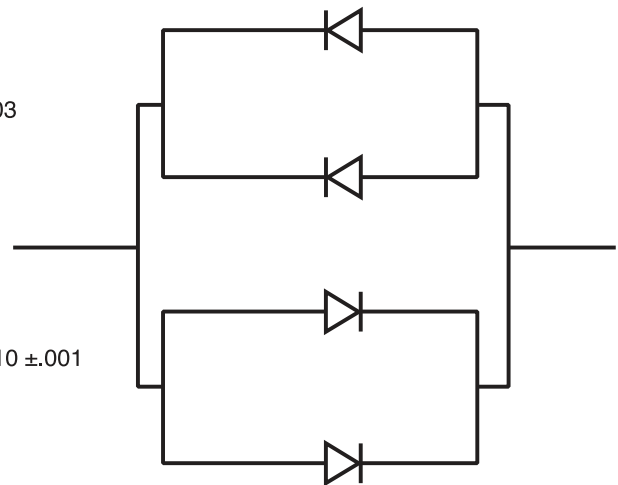
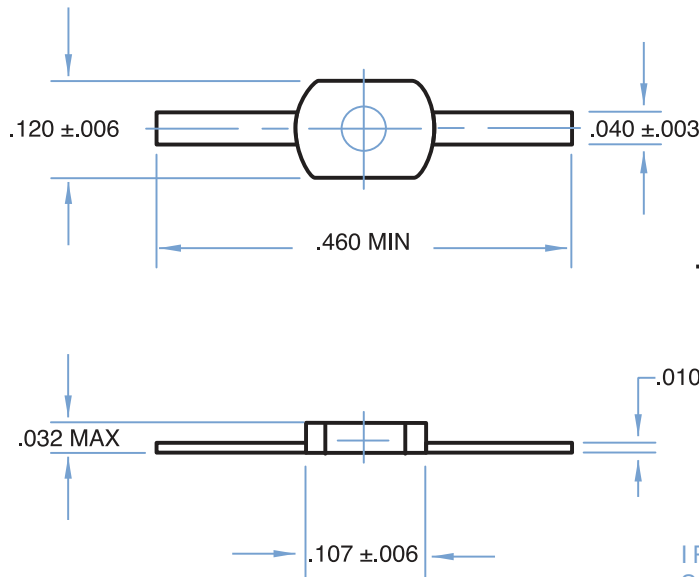

$I_{RMS}$	100 milliamps maximum
Saturation Current	Less Than 50 milliamps
Minority Carrier Lifetime	24 nanoseconds (nominal)



# Non Magnetic Hardware



Due to the severe non-magnetism requirements in the magnetic resonance industries, we use only high purity metals that exhibit no measurable magnetism. Commercial brass is simply not acceptable for these applications. Our strict traceability and testing regimes insure this essential parameter.

We can offer sizes, styles, and lengths beyond those shown in the tables on these pages – such as Cheese Head, Round Head, and set screws. We also offer flat washers to complete your needs.

## Pan Head

## Flat Head

2-56 Thread	
48-109	5/64"
48-107	3/32"
48-105	3/16"
48-100	1/25"
48-106	5/16"
48-101	3/8"
48-102	1/2"
48-101	5/8"
48-104	3/4"
48-108	1"
48-500	Hex Nut
4-40 Thread	
48-115	3/16"
48-110	1/4"
48-116	5/16"
48-111	3/8"
48-112	1/2"
48-117	5/8"
48-113	3/4"
48-114	1"
48-118	2"
48-501	Hex Nut
6-32 Thread	
48-120	1/4"
48-124	3/16"
48-121	3/8"
48-122	1/2"
48-123	3/4"
48-125	1"
48-502	Hex Nut
8-32 Thread	
48-130	1/4"
48-131	3/8"
48-132	1/2"
48-133	3/4"
48-503	Hex Nut
10-32 Thread	
48-140	1/4"
48-141	3/8"
48-142	1/2"
48-143	5/8"
48-144	3/4"
48-145	1"
48-505	Hex Nut
1/4-20 Thread	
48-150	3/8"
48-152	1/2"
48-151	1"
48-153	1-1/4"
48-506	Hex Nut

M2 x .4 Thread	
48-300	6mm
48-301	12mm
48-302	16mm
48-600	Hex Nut
M2.5 x .45 Thread	
48-310	8mm
48-601	Hex Nut
M3 x .5 Thread	
48-320	5mm
48-321	6mm
48-322	7.5mm
48-323	8mm
48-324	10mm
48-325	12mm
48-326	16mm
48-327	20mm
48-602	Hex Nut
M4 x .7 Thread	
48-330	8mm
48-331	10mm
48-332	12mm
48-333	16mm
48-334	20mm
48-335	25mm
48-603	Hex Nut
M5 x .8 Thread	
48-340	8mm
48-341	10mm
48-342	12mm
48-343	16mm
48-344	20mm
48-345	25mm
48-604	Hex Nut

2-56 Thread	
48-205	9/64"
48-203	3/16"
48-200	1/4"
48-204	3/8"
48-201	1/2"
48-202	1"
48-500	Hex Nut
4-40 Thread	
48-210	1/4"
48-216	5/16"
48-211	3/8"
48-212	1/2"
48-213	3/4"
48-214	1"
48-215	1-1/4"
48-501	Hex Nut
6-32 Thread	
48-220	1/4"
48-221	3/8"
48-228	7/16"
48-222	1/2"
48-223	3/4"
48-224	1"
48-225	1-1/4"
48-229	1-3/8"
48-226	1-1/2"
48-227	1-3/4"
48-502	Hex Nut
8-32 Thread	
48-230	3/8"
48-231	1/2"
48-232	5/8"
48-233	3/4"
48-503	Hex Nut
10-32 Thread	
48-240	3/8"
48-241	1/2"
48-242	5/8"
48-243	3/4"
48-244	1"
48-245	1-1/4"
48-505	Hex Nut
1/4-20 Thread	
48-250	3/4"
48-506	Hex Nut

M2 x .4 Thread	
48-400	5mm
48-401	10mm
48-600	Hex Nut
M3 x .5 Thread	
48-415	6mm
48-410	8mm
48-411	10mm
48-412	12mm
48-413	16mm
48-414	20mm
48-602	Hex Nut
M4 x .7 Thread	
48-420	8mm
48-421	10mm
48-422	12mm
48-423	16mm
48-424	20mm
48-603	Hex Nut
M5 x .8 Thread	
48-430	8mm
48-431	10mm
48-432	12mm
48-433	16mm
48-434	20mm
48-435	25mm
48-604	Hex Nut



Coils also require inserts, pins, and other special shapes that are custom-designed to satisfy the specific requirements of the coil designer. The ability to quickly and precisely supply custom designs is part of our heritage and we are eager to sample our high quality hardware based on your requirements. As with the screws, washers, and nuts on this and the preceding page, we use only high purity metals that exhibit no measurable magnetism.