

STN06 1050B300

TVS Diode ESD suppressor



Product features

- Protects one bi-directional I/O line
- Low clamping voltage
- Low operating voltage: 5.0 V
- Low leakage current
- Ultra-low capacitance
- Meets moisture sensitivity level (MSL) 3
- Molding compound flammability rating: UL 94V-0
- Termination finish: Ni/Pd/Au

Applications

- USB ports
- Display port
- Wireless communications
- Digital visual interface (DVI)
- Cellular handsets & accessories

Environmental compliance and general specifications

- IEC61000-4-2 (ESD)
 - ± 30 kV (air)
 - ± 30 kV (contact)
- IEC61000-4-5 (Lightning) 3.5 A (8/20 μs)



Ordering part number

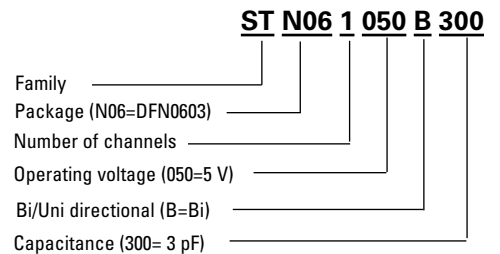

Pin out/functional diagram



DFN0603-2L



Absolute maximum ratings

(+25 °C, RH=45%-75%, unless otherwise noted)

STN061050B300

Parameter	Symbol	Value	Unit
Peak pulse power dissipation on 8/20 μs waveform	P_{pp}	41	W
ESD per IEC 61000-4-2 (Air)	V_{ESD}	+/-30	kV
ESD per IEC 61000-4-2 (Contact)		+/-30	
Lead soldering temperature	T_L	+260 (10 seconds)	°C
Operating junction temperature range	T_J	-55 to +125	°C
Storage temperature range	T_{STG}	-55 to +150	°C

Electrical characteristics

(+25 °C)

STN061050B300

Parameter	Test condition	Minimum	Typical	Maximum	Symbol (Units)
Reverse working voltage	-	-	-	5.0	V_{RWM} (V)
Reverse breakdown voltage	$I_T = 1$ mA	5.3	-	-	V_{BR} (V)
Reverse leakage current	$V_{RWM} = 3.3$ V	-	-	0.1	I_R (μA)
Holding voltage	$t_p = 8/20$ μs	5.3	-	-	V_H (V)
Clamping voltage	$I_{pp} = 16$ A, $t_p = 100$ ns	-	15	-	V_C (V)*
	$V_{ESD} = 8$ kV	-	15	-	V_C (V)**
	$I_{pp} = 1$ A, $t_p = 8/20$ μs	-	-	8.5	V_C (V)***
	$I_{pp} = 7$ A, $t_p = 8/20$ μs	-	-	12	V_C (V)***
Dynamic resistance	$t_p = 100$ ns	-	0.35	-	R_{DYN} (Ω)*
Junction capacitance	$V_{RWM} = 0$ V, $f = 1$ MHz	-	3.0	4.0	C_J (pF)
	$V_{RWM} = 2.5$ V, $f = 1$ MHz	-	2.4	3.0	C_J (pF)

*TLP parameter: $Z_0 = 50$ Ω, $t_P = 100$ ns, $t_r = 2$ ns, averaging window from 60 ns to 80 ns. RDYN is calculated from 4 A to 16 A.

** Contact discharge mode, according to IEC61000-4-2.

*** Non-repetitive current pulse, according to IEC61000-4-5.

Mechanical parameters, pad layout- mm

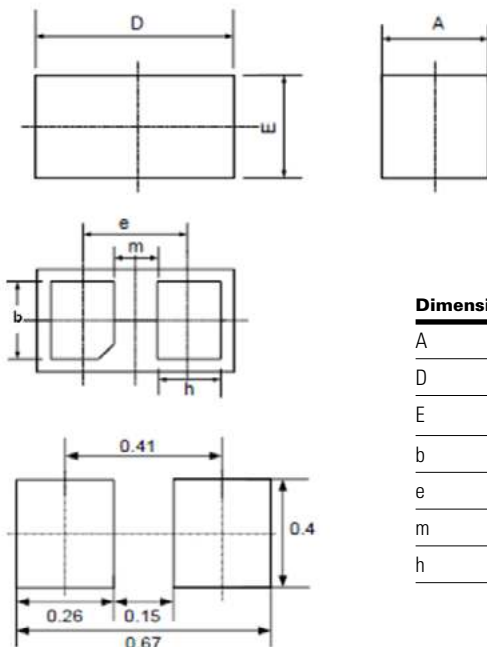

Dimension	Minimum	Maximum
A	0.28	0.32
D	0.55	0.65
E	0.25	0.35
b	0.20	0.30
e	0.350	
m	0.165	
h	0.14	0.24

Part marking



Land Pattern

Packaging information- mm/inches

Drawing not to scale.

Supplied in tape and reel packaging, 10,000 parts per 7" diameter reel (EIA-481 compliant)

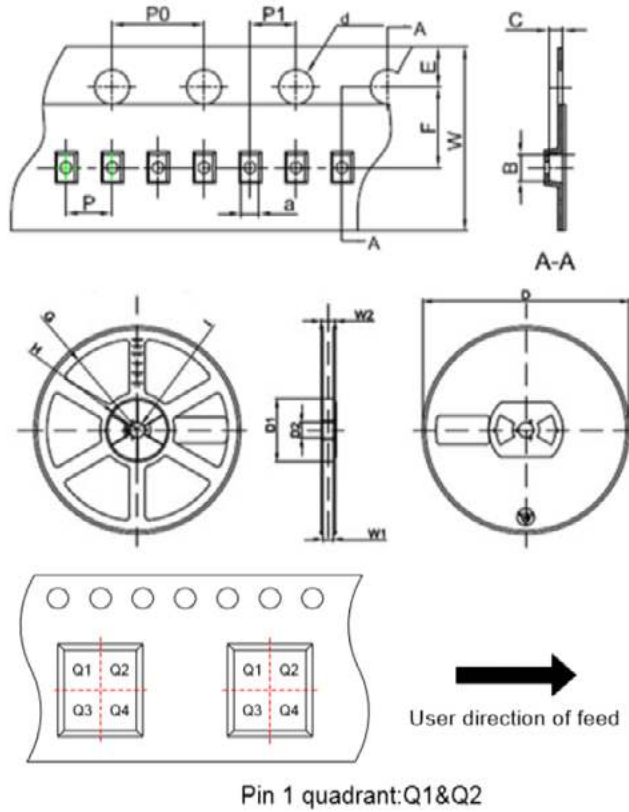

Symbol	Millimeters	Inches
	Typ.	Typ.
a	0.41	0.016
B	0.70	0.028
C	0.38	0.015
d	Φ1.50	Φ0.059
E	1.75	0.069
F	3.50	0.138
P0	4.00	0.157
P	2.00	0.079
P1	2.00	0.079
W	8.00	0.315
D	Φ178	Φ7.008
D1	54.40	2.142
D2	13.00	0.512
G	R78.00	R3.071
H	R25.60	R1.008
I	R6.50	R0.256
W1	9.50	0.374
W2	12.30	0.484

Ratings and V-I characteristic curves (+25 °C unless otherwise noted)

V- I curve characteristics (Bi-directional)

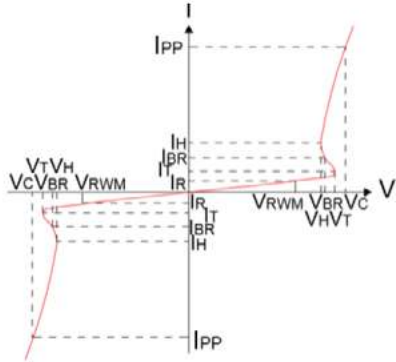

Pulse waveform (8/20 μ s)

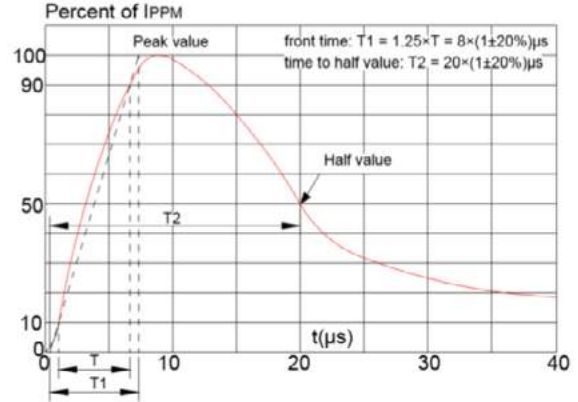

Pulse derating curve

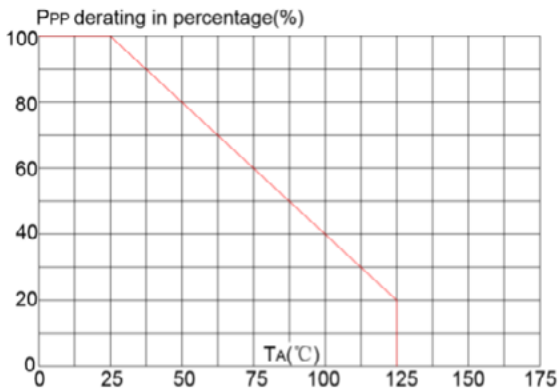

ESD waveform

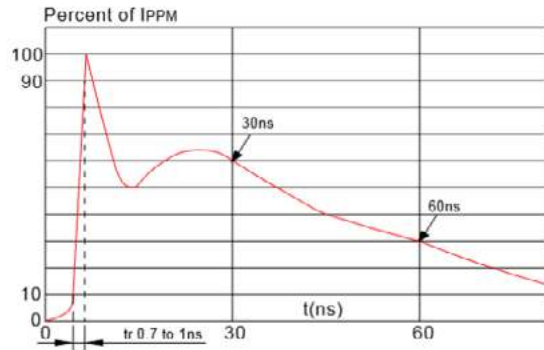

Clamping voltage vs. peak pulse current

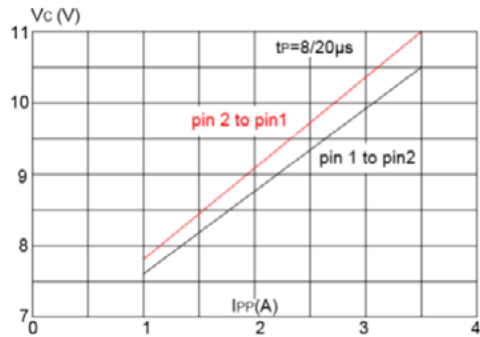

TLP Measurement

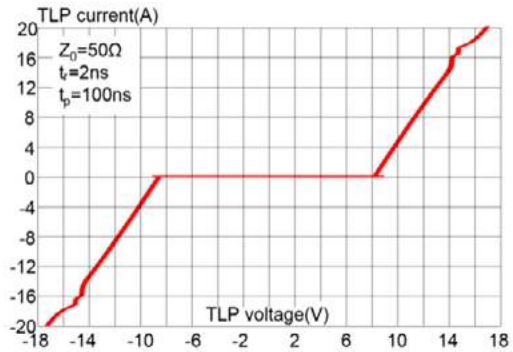

Solder reflow profile

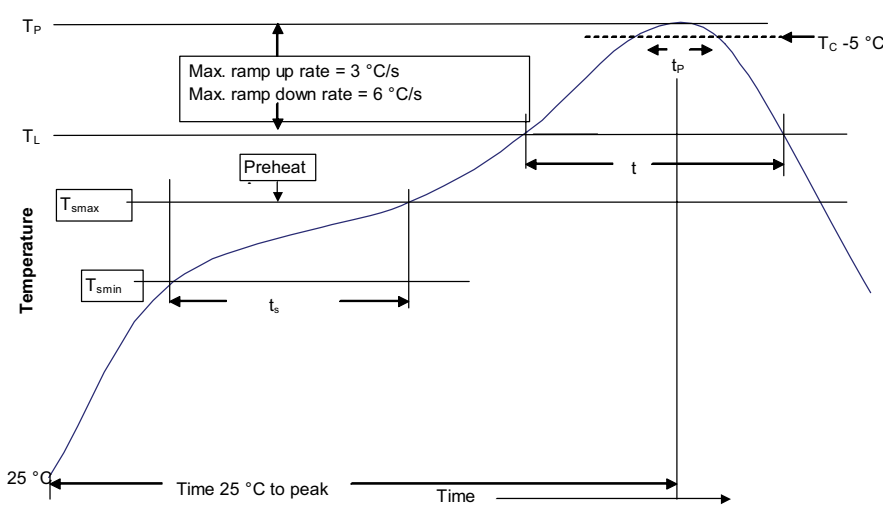

Table 1 - Standard SnPb solder (T_C)

Package thickness	Volume mm^3 <350	Volume mm^3 \geq 350
<2.5 mm	235 °C	220 °C
\geq 2.5 mm	220 °C	220 °C

Table 2 - Lead (Pb) free solder (T_C)

Package thickness	Volume mm^3 <350	Volume mm^3 350 - 2000	Volume mm^3 >2000
<1.6 mm	260 °C	260 °C	260 °C
1.6 – 2.5 mm	260 °C	250 °C	245 °C
>2.5 mm	250 °C	245 °C	245 °C

Reference J-STD-020

Profile feature	Standard SnPb solder	Lead (Pb) free solder
Preheat and soak		
• Temperature min. (T_{smin})	100 °C	150 °C
• Temperature max. (T_{smax})	150 °C	200 °C
• Time (T_{smin} to T_{smax}) (t_s)	60-120 seconds	60-120 seconds
Ramp up rate T_L to T_p	3 °C/ second max.	3 °C/ second max.
Liquidous temperature (T_L)	183 °C	217 °C
Time (t_L) maintained above T_L	60-150 seconds	60-150 seconds
Peak package body temperature (T_p)*	Table 1	Table 2
Time (t_p)* within 5 °C of the specified classification temperature (T_C)	20 seconds*	30 seconds*
Ramp-down rate (T_p to T_L)	6 °C/ second max.	6 °C/ second max.
Time 25 °C to peak temperature	6 minutes max.	8 minutes max.

* Tolerance for peak profile temperature (T_p) is defined as a supplier minimum and a user maximum.

Life Support Policy: Eaton does not authorize the use of any of its products for use in life support devices or systems without the express written approval of an officer of the Company. Life support systems are devices which support or sustain life, and whose failure to perform, when properly used in accordance with instructions for use provided in the labeling, can be reasonably expected to result in significant injury to the user.

Eaton reserves the right, without notice, to change design or construction of any products and to discontinue or limit distribution of any products. Eaton also reserves the right to change or update, without notice, any technical information contained in this bulletin.

Eaton
Electronics Division
1000 Eaton Boulevard
Cleveland, OH 44122
United States
Eaton.com/electronics

© 2020 Eaton
All Rights Reserved
Printed in USA
Publication No. 11137 BU-MC20119
September 2020

Eaton is a registered trademark.
All other trademarks are property of their respective owners.

Follow us on social media to get the latest product and support information.

