

MARKETING SALES DRAWING

DIMENSIONS IN INCHES - DO NOT SCALE THIS DRAWING
DIMENSIONS IN METRIC - []

This drawing is the property of Tusonix, Inc., and may not be used, reproduced, published or disclosed to others without expressed authorization by Tusonix Inc.

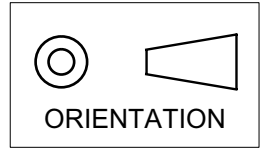

Electrical Testing
per Tusonix standard
test plans and Mil-Std-202
Test Methods.

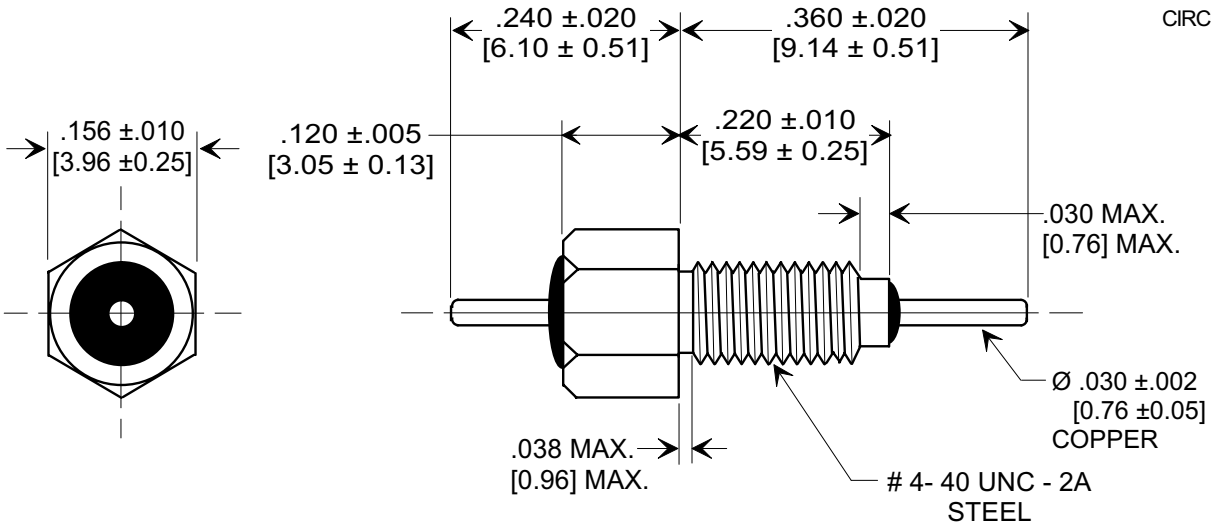
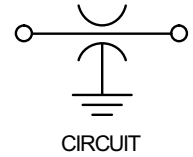

MOUNTING HARDWARE

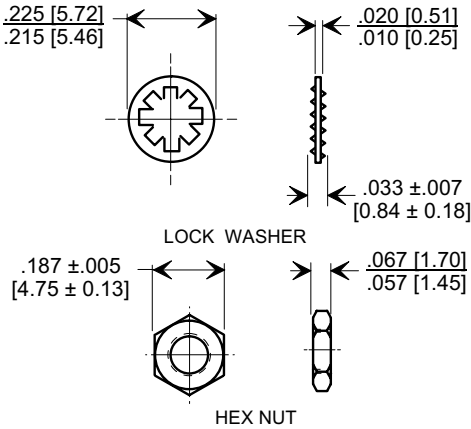

NOTES:

1. OPERATING TEMPERATURE RANGE: -55°C to +125°C.
2. SILVER PLATED CASE, LEAD AND MOUNTING HARDWARE.
3. MAX. RECOMMENDED MOUNTING TORQUE: 2.0 lb. - in. [0.23 Nm].
4. MAX. RECOMMENDED SOLDERING TEMPERATURE: 260°C. SEE INSTALLATION RECOMMENDATIONS.
5. NUT AND LOCK WASHER INCLUDED.
6. TUSONIX STANDARD PART NUMBER: 4400-680. TUSONIX RoHS COMPLIANT PART NUMBER: 4400-680 LF. CUSTOMER MUST SPECIFY STANDARD OR RoHS PART NUMBER WHEN ORDERING.
7. PART MARKING: TRADEMARK AND VARIATION NUMBER ON HEX FLATS. STANDARD PART, BLACK INK, RoHS PART DARK GREEN FOR IDENTIFICATION.

CAP.(pf)	TOLERANCE	DC WORKING VOLTAGE		DC CURRENT (AMPS)	IR @ 100 VDC	DWV	MIN. NO LOAD INSERTION LOSS (dB) @ 25°C PER MIL-STD-220				
		85°C	125°C				1 MHz	10 MHz	100 MHz	1 GHz	10 GHz
5	MAX	300	200	10	10 G Ω MIN.	500 VDC	----	----	----	----	----

REVISION RECORD Original Release C.O. 20020731-1-01 REVISED AND ADDED NOTES. REMOVED STYLE BOX. S.M. 11-04-05 20051102-2-02 REVISED TITLE. ADDED METRIC TO NOTE 3. S.M. 02-13-06 20060123-9-02	0	1	2	--TOLERANCES-- Unless Otherwise Specified	Title LINE FEED-THRU	
	DECIMAL ± NOTED			Drawn S.M. 07-31-02 Scale 5 X		
	ANGLES ±	Approved B.Mc 07-31-02		TUSONIX TUCSON, ARIZONA		
	A					