

Demonstration Board EPC9131 Quick Start Guide

19 V Regulated SEPIC Using EPC2112

Revision 1.0



DESCRIPTION

The EPC9131 demonstration board is a 19 V output, 300 kHz single-ended primary-inductor converter (SEPIC) with a 27 W maximum output power and 14 V to 48 V input voltage range. The demonstration board features the EPC2112 enhancement mode (eGaN®) integrated circuit (IC), as well as the LM3481 controller intended for use with MOSFETs.

The EPC9131 board contains the complete power stage (including eGaN IC, driver, inductors and input/output capacitors) in a compact 25 mm x 33 mm layout to showcase the performance that can be achieved using the eGaN IC. It also contains a closed-loop SEPIC with optimized control loop. The total board dimension is 48 mm x 50 mm.

There are also various probe points to facilitate efficiency measurement. A complete power schematic block diagram of the circuit is given in figure 1.

For more information on the EPC2112 eGaN IC or LM3481 controller, please refer to the datasheet available from EPC at www.epc-co.com and www.ti.com respectively. These datasheets should be read in conjunction with this quick start guide.

QUICK START PROCEDURE

Demonstration board EPC9131 is easy to set up to evaluate the performance of the EPC2112 eGaN IC and directly driven from the controller IC. Refer to figure 2 for proper connection and measurement setup and follow the procedure below:

1. With power off, connect the input power supply bus between V_{IN} and GND, J2, as shown.
2. With power off, connect the load as desired between V_{OUT} and GND, J3, as shown.
3. Turn on the supply voltage beyond UVLO to the required value (do not exceed the absolute maximum voltage of 48 V on V_{IN}).
4. Measure the output voltage to make sure the board is fully functional and operating no-load.
5. Turn on active load to the desired power/current while staying below the maximum power (27 W/1.42 A).
6. Once operational, adjust the bus voltage and load current within the allowed operating range and observe the output switching behavior, efficiency and other parameters.
7. For shutdown, please follow steps in reverse.

NOTE. When measuring the high frequency content switch node, care must be taken to avoid long ground leads. For details, please refer to [AN023 Accurately Measuring High Speed GaN Transistors.pdf](#).



EPC9131 demonstration board

Table 1: Performance Summary ($T_A = 25^\circ\text{C}$) EPC9131

Symbol	Parameter	Conditions	Min	Typ	Max	Units
V_{CC}	Bus Input Voltage Range		14		48	V
V_{IN}	Output Voltage			19		V
I_{OUT}	Output Power		0		27	W
f_{sw}	UVLO Enable	Input Voltage Rising			13.8	V
V_{PWM}	UVLO Disable	Input Voltage Falling	5			V
	Switching Frequency			300		kHz
V_{PWM}	Max. Input Current	Limited by the controller at 14 V input		2*		A

*Actual maximum current subject to operating temperature limits.

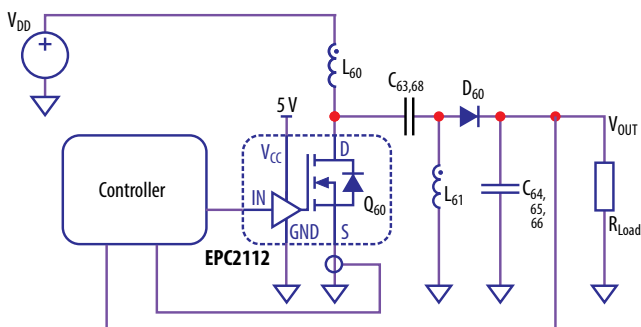

Figure 1. Power schematic block diagram of the EPC9131 demonstration board.

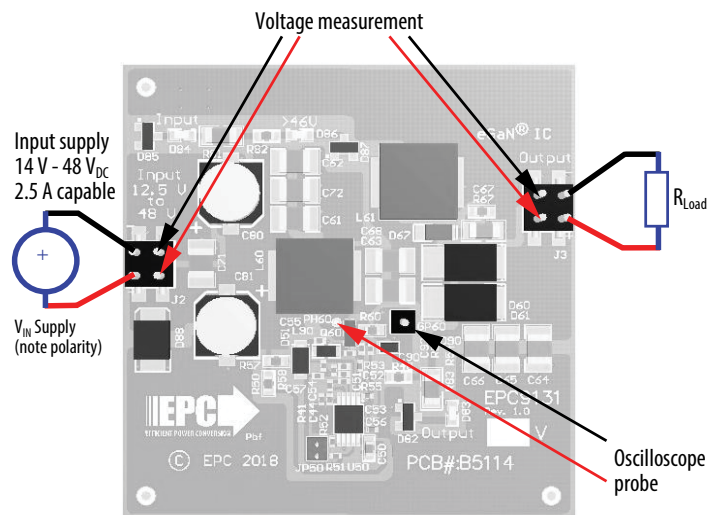

Figure 2. Power schematic block diagram of the EPC9131 demonstration board.

CIRCUIT PERFORMANCE

The EPC9131 demonstration circuit was designed to showcase the performance of eGaN IC that can readily be achieved at 300 kHz operation for supply voltages up to 48 V. Since a closed loop controller is included on board, the associated losses must also be lumped into any efficiency measurement that is performed. In an effort to mitigate these losses and focus on the efficiency of the power stage, the controller is powered directly from the input. Thus the controller and logic losses are still included.

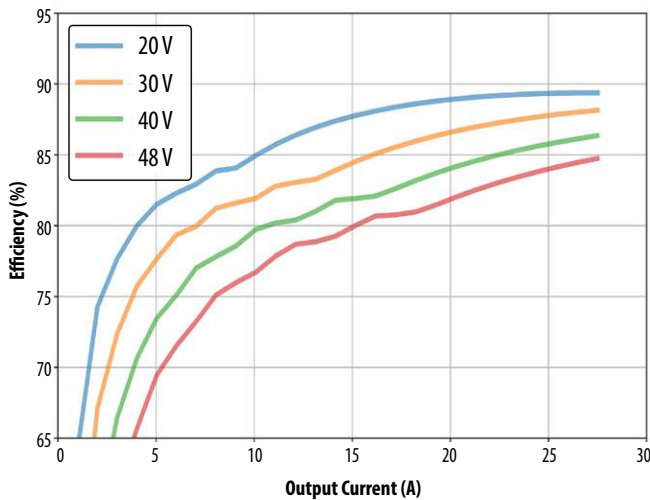

Figure 3: EPC9131 typical efficiency measurement for various input voltages and output power levels.

Typical efficiency curves of the converter for different input voltages and different output power levels are shown in figure 3.

Figure 4 shows the measured switch-node voltage of the eGaN IC operating with 48 V input and delivering 27 W at 19 V into the load. Figure 5 shows the waveform zoomed in to reveal details of the voltage transition.

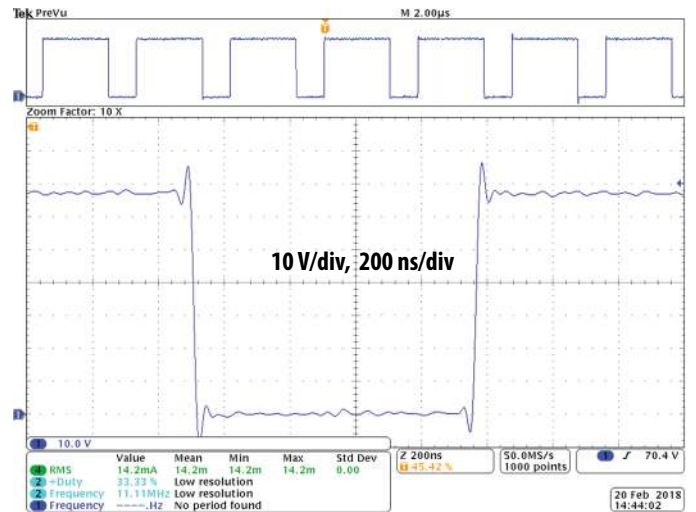

Figure 4: Measured switch-node waveforms for 48 V input to 19 V output at 27 W load power (300 kHz).

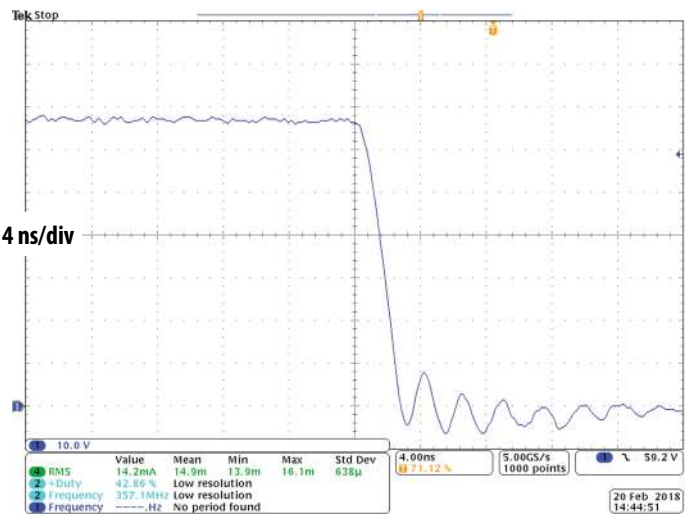
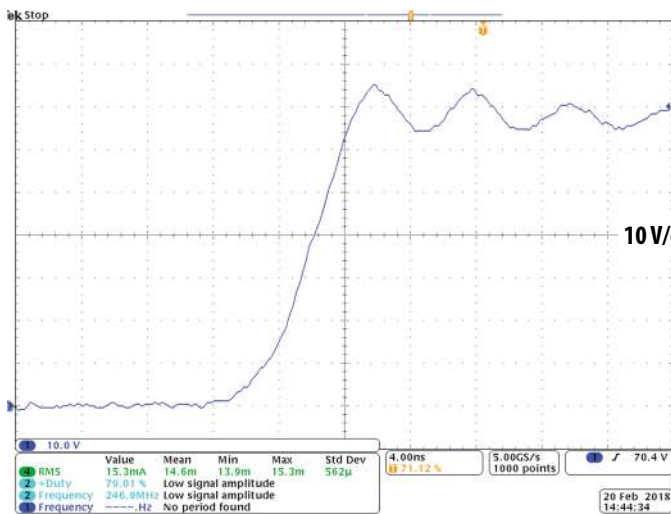

Figure 5: Zoomed-in measured switch-node waveforms for 48 V input to 19 V output at 27 W load power (300 kHz).

Figure 6 shows a thermal image of the EPC9131 operating at with 48 V input and 19 V output delivering 27 W into the load and reveals that the hottest component is the controller IC.

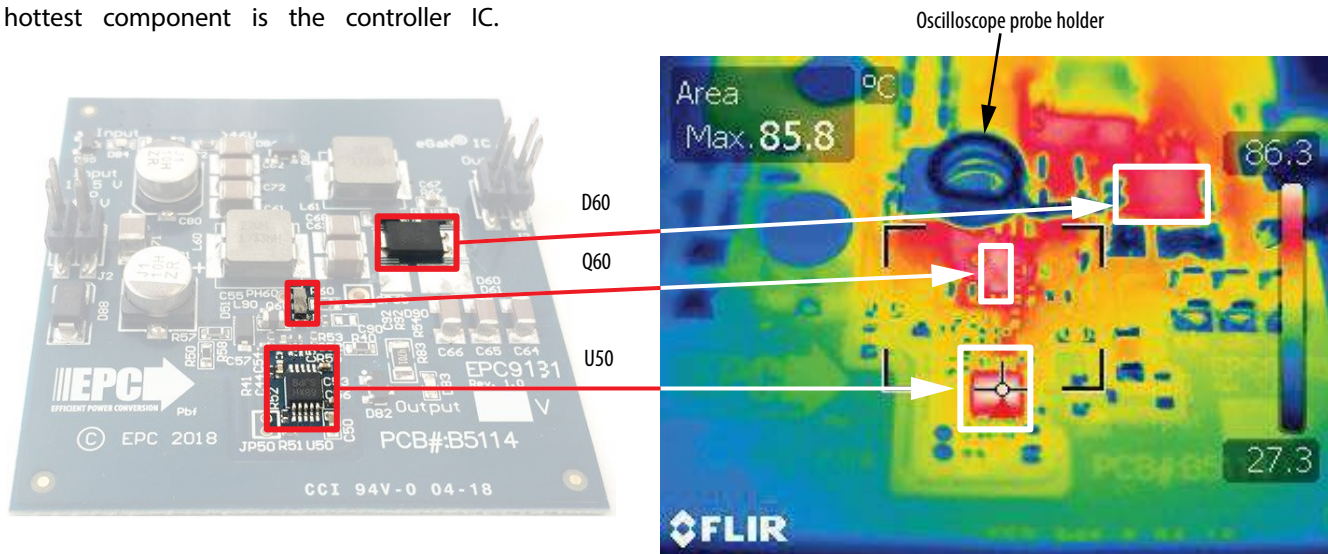

Figure 6: Thermal image of the EPC9131 operating at with 48 V input and 19 V output delivering 27 W into the load.

THERMAL CONSIDERATIONS

The EPC9131 is intended for bench evaluation with low ambient temperature. The addition of heat-sinking and forced air cooling could potentially increase the output power capability of the demonstration circuit, but care must be taken to not exceed the absolute maximum

die temperature of 150°C and stay within the constraints of the other components within the circuit, most notably the output diode and saturation of the inductors.

Table 2a: Bill of Materials

Item	Qty	Reference	Part Description	Manufacturer	Part #
1	1	C44	100 pF, 25 V	Würth	885012205038
2	1	C50	100 nF, 100 V	Murata	GRM188R72A104KA35D
3	3	C51, C56, C57	100 nF, 16 V	Würth	885012205037
4	1	C53	220 pF, 50 V	Murata	GRM155R71H221KA01D
5	2	C55, C90	1 µF, 25 V	TDK	C1005X5R1E105M050BC
6	6	C61, C62, C63, C68, C71, C72	10 µF 50 V	Taiyo Yuden	UMK325BJ106MM-T
7	3	C64, C65, C66	22 µF 35 V	TDK	C3216JB1V226M160AC
8	1	C67	10 nF, 200 V	Kemet	C0603C103K2RACTU
9	2	C80, C81	10 µF 50 V	Nichicon	UZR1H100MCL1GB
10	1	C92	22 pF, 50 V	Würth	885012005057
11	1	D51	30 V 500 mA	ST	STPS0530Z
12	1	D60	100 V 5A	Diodes	PDS5100-13
13	1	D67	200 V, 1A	Diodes Inc.	DFLS1200
14	2	D82, D85	2.7 V 250 mW	NXP	BZX84-C2V7,215
15	1	D83	LED 0603 Blue	Lite-On	LTST-C193TBKT-5A
16	1	D84	LED 0603 Green	Lite-On	LTST-C193KGKT-5A
17	1	D86	LED 0603 Red	Lite-On	LTST-C193KRKT-5A
18	1	D87	43 V 250 mW	Nexperia	BZX84-C43,215
19	1	D88	38 V, 7.5 A	Littelfuse	SMAJ33A
20	2	J2, J3	.1" Male Vert.	Amphenol FCI	95278-101A04LF

Table 2b: Bill of Materials

Item	Qty	Reference	Part Description	Manufacturer	Part #
21	2	L60, L61	22 μ H 2.9A	Vishay Dale	IHLP2525CZER220M11
22	1	L90	10 μ H 150 mA	Taiyo Yuden	LBR2012T100K
23	1	Q60	200 V 6A 40 m Ω	EPC	EPC2112
24	1	R40	84.5 k 1%	Panasonic	ERJ-3EKF8452V
25	1	R41	6.04 k	Panasonic	ERJ-2RKF6041X
26	1	R50	10 Ω	Panasonic	ERJ-3EKF10R0V
27	1	R51	124 k 1%	Panasonic	ERJ-2RKF1243X
28	1	R52	56.2 k 1%	Yageo	RC0402FR-0756K2L
29	1	R53	2.32 k	Yageo	RC0402FR-072K32L
30	1	R54	300 Ω	Yageo	RC0402JR-07300RL
31	1	R57	300 k 1%	Panasonic	ERJ-3EKF3003V
32	1	R58	34 k 1%	Yageo	RC0402FR-0734KL
33	1	R60	22 m Ω 0.4 W	Vishay Dale	WSLP0603R0220FEB
34	1	R67	10 k 5% 2/3 W	Panasonic	ERJ-P08J103V
35	2	R81, R83	4.7 k	Stackpole	RMCF1206FT4K70
36	1	R82	422 Ω	Yageo	RMCF0603FT422R
37	1	R92	20 Ω	Stackpole	RMCF0402JT20R0
38	1	U50	Boost Controller	Texas Instruments	LM3481MM/NOPB

Table 3: Optional Components

Item	Qty	Reference	Part Description	Footprint
1	3	C52, C54, R55	Ceramic Capacitor high Q	CC0402sml
2	1	D61	Diode 100 V, 5 A	PowerDi5SMB
3	1	D90	Diode, 5 V1, 150 mW	D0603
4	1	GP60	.1" Male Vert.	SIP1
5	1	JP50	.05" 2 pos Male Vert	SIP2.05

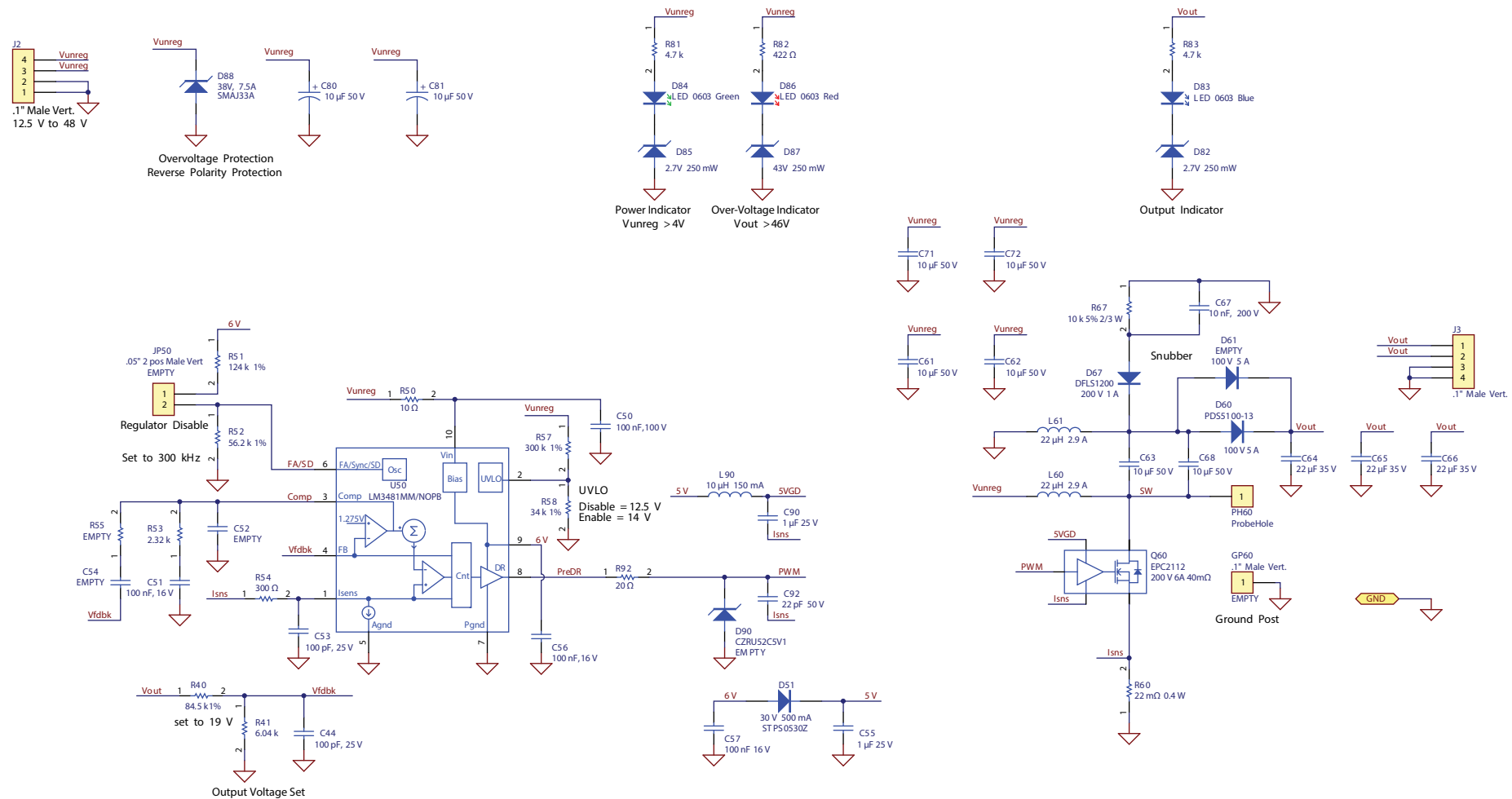

Figure 7: EPC9131 schematic

For More Information:

Please contact info@epc-co.com
or your local sales representative

Visit our website:
www.epc-co.com

Sign-up to receive
EPC updates at
bit.ly/EPCupdates
or text "EPC" to 22828



EPC Products are distributed through Digi-Key.
www.digikey.com

Demonstration Board Notification

The EPC9131 board is intended for product evaluation purposes only and is not intended for commercial use. Replace components on the Evaluation Board only with those parts shown on the parts list (or Bill of Materials) in the Quick Start Guide. Contact an authorized EPC representative with any questions.

This board is intended to be used by certified professionals, in a lab environment, following proper safety procedures. Use at your own risk.

As an evaluation tool, this board is not designed for compliance with the European Union directive on electromagnetic compatibility or any other such directives or regulations. As board builds are at times subject to product availability, it is possible that boards may contain components or assembly materials that are not RoHS compliant. Efficient Power Conversion Corporation (EPC) makes no guarantee that the purchased board is 100% RoHS compliant.

The Evaluation board (or kit) is for demonstration purposes only and neither the Board nor this Quick Start Guide constitute a sales contract or create any kind of warranty, whether express or implied, as to the applications or products involved.

Disclaimer: EPC reserves the right at any time, without notice, to make changes to any products described herein to improve reliability, function, or design. EPC does not assume any liability arising out of the application or use of any product or circuit described herein; neither does it convey any license under its patent rights, or other intellectual property whatsoever, nor the rights of others.