

Property of
Sensata Technologies

REVISIONS									
ZONE	LTR	DEV. #	2CP	DESCRIPTION	PROJ. #	3514	DATE	APPROVED	
	F	ADDED TO NOTE #2 "CONFORMING TO UL 1015" C.R. M44312			J.D.M.	1-11-99	E.M.M.		

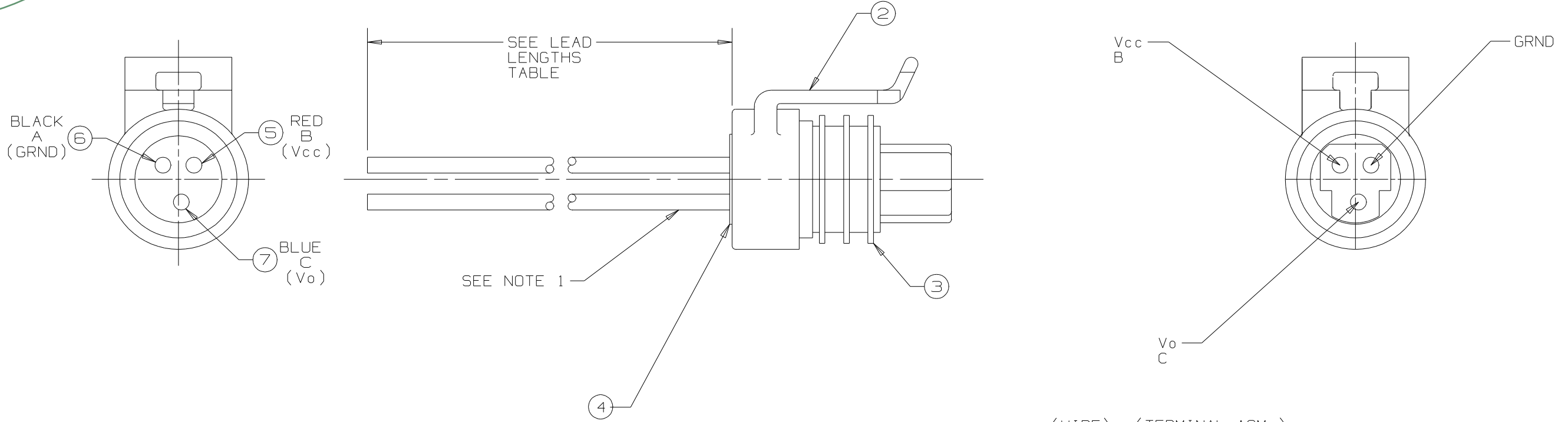

NOTES:

- PULL TO SEAT WIRE AND TERMINAL ASSEMBLIES (3-PL.).
- EACH WIRE IS TO BE MADE UP OF TWISTED STRANDS CONSTITUTING A 22 GAUGE DIAMETER AND JACKETED WITH PVC INSULATION, CONFORMING TO UL 1015.

		(WIRE)			(TERMINAL ASM.)			
		1	1	1	7	2832	& 12089290	WIRE AND TERMINAL ASM.
		1	1	1	6	1074	& 12089290	WIRE AND TERMINAL ASM.
		1	1	1	5	4886	& 12089290	WIRE AND TERMINAL ASM.
		1	1	1	4	12065285		CABLE SEAL
		1	1	1	3	12052893		CONNECTOR SEAL
		1	1	1	2	12065286		CONNECTOR BODY
					1			ASSEMBLY

QUANTITY			ITEM NO	TM MORRIS(WIRE ONLY) & PACKARD ELECTRIC DIVISION PART NO.	DESCRIPTION
-3	-2	-1			
DASH NO					

THIS DRAWING SUPERSEDES 28810 REV."E" DATED 12-09-98.

DASH NO.	LENGTH
28810-3	117.5/118.5
28810-2	80.0/ 79.0
28810-1	40.0/ 39.0
LEAD LENGTHS	

UNLESS OTHERWISE SPECIFIED DIMENSIONS ARE IN INCHES		DRAWN O. LARSEN	DATE 12-20-96	RS	VS	M21	P35
TOLERANCES ON FRACTIONS DECIMALS ANGLES		ENGINEER SUCHARITA SAHU	12-20-96	TEXAS INSTRUMENTS ATTLEBORO, MASSACHUSETTS 02703		KLIXON CONTROL PRODUCTS DIVISION	
MATERIAL		APPROVED D. R. SOGGE	12-20-96	TITLE WIRE HARNESS (UL 1015)			
		APPROVED E. J. WILKINSON	12-20-96	SIZE B	CODE IDENT NO. 82647	28810	
SIGNATURES ON FILE. REFER TO ELECTRONIC CHANGE NOTICE.							