

THIS DRAWING IS UNPUBLISHED. RELEASED FOR PUBLICATION 20
 © COPYRIGHT 20 BY - ALL RIGHTS RESERVED.

REVISIONS				
P	LTR	DESCRIPTION	DATE	APVD
1		INITIAL RELEASE	22AUG2018	SH SH
2		ADDED DIMENSION FOR PLUGGED IN	09NOV2018	SH SH
A		INITIAL RELEASE	12JUN2019	SH SH
A1		REVISED PER ECO-19-016397	19OCT2019	SH SH

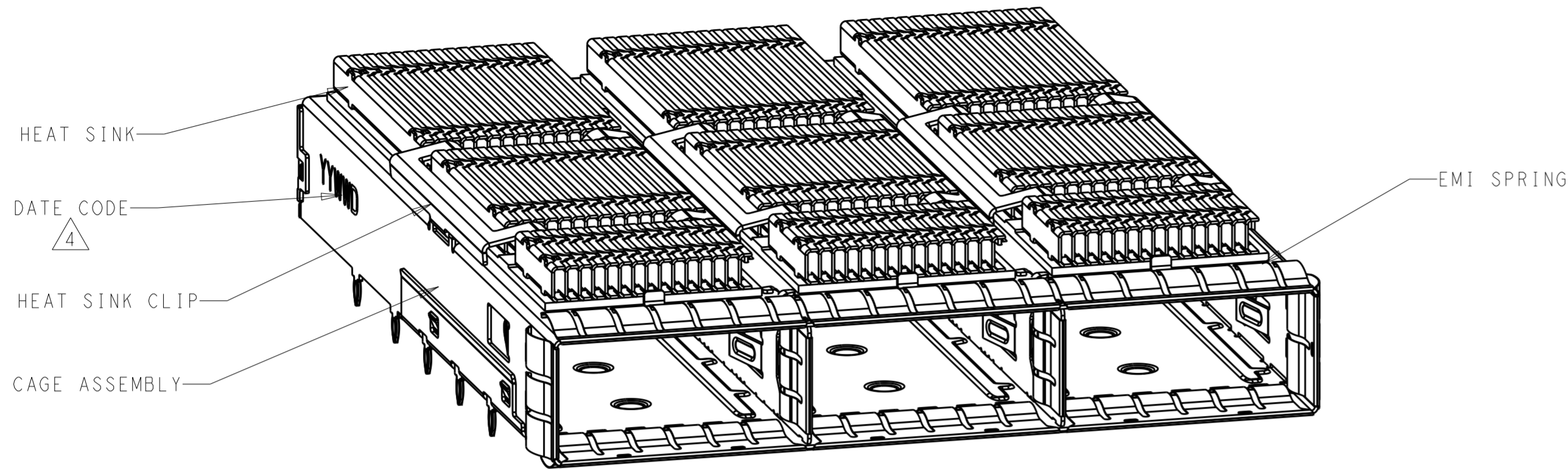

- ① CAGE ASSEMBLY: STAINLESS STEEL
HEAT SINK: ALUMINUM/ NICKEL PLATED
HEAT SINK CLIP: STAINLESS STEEL
EMI SPRING: COPPER ALLOY/ NICKEL PLATED
- ② REFERENCE APPLICATION SPECIFICATION 114-60025 FOR RECOMMENDED DRILL HOLE DIAMETER AND PLATING THICKNESS. BOARD LAYOUT PER THIS PRINT.
- ③ DATUM AND BASIC DIMENSION ESTABLISHED BY CUSTOMER
- ④ DATE CODE (YYWWD) MARKED APPROXIMATELY AS SHOWN.
- 5. MATES WITH QSFP-DD MSA COMPATIBLE TRANSCEIVER.
- 6. MINIMUM PC BOARD THICKNESS:
SINGLE SIDED: 1.57 MIN
DOUBLE SIDED: 3.0 MIN

2342886-1 AS SHOWN

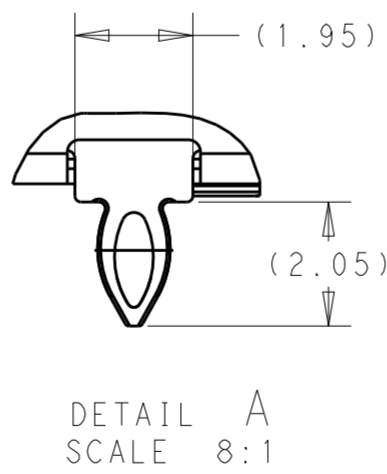
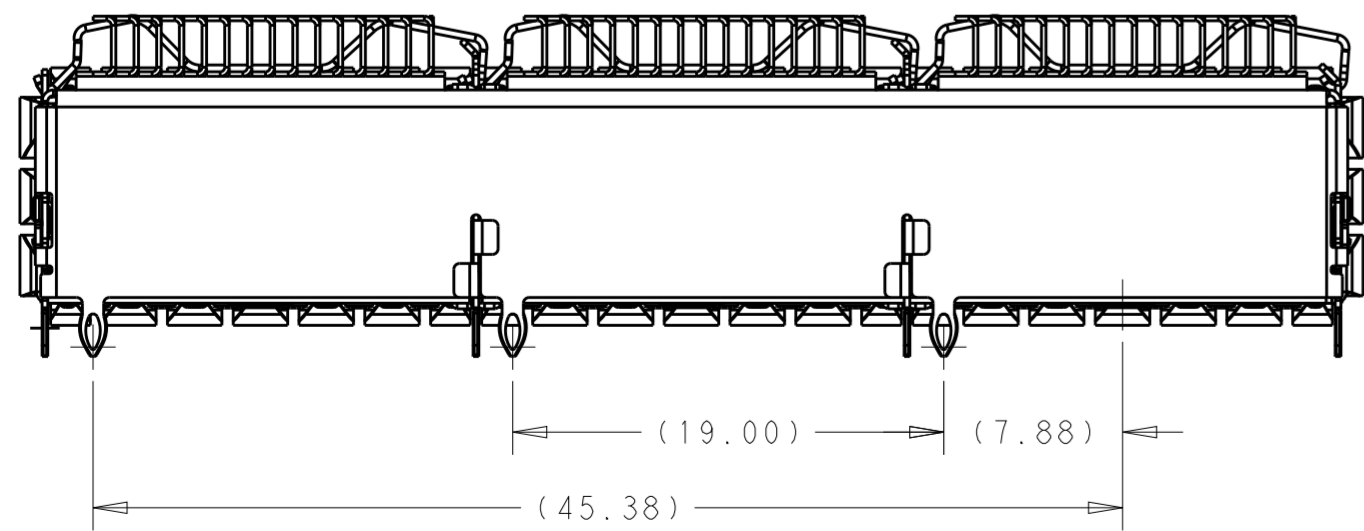
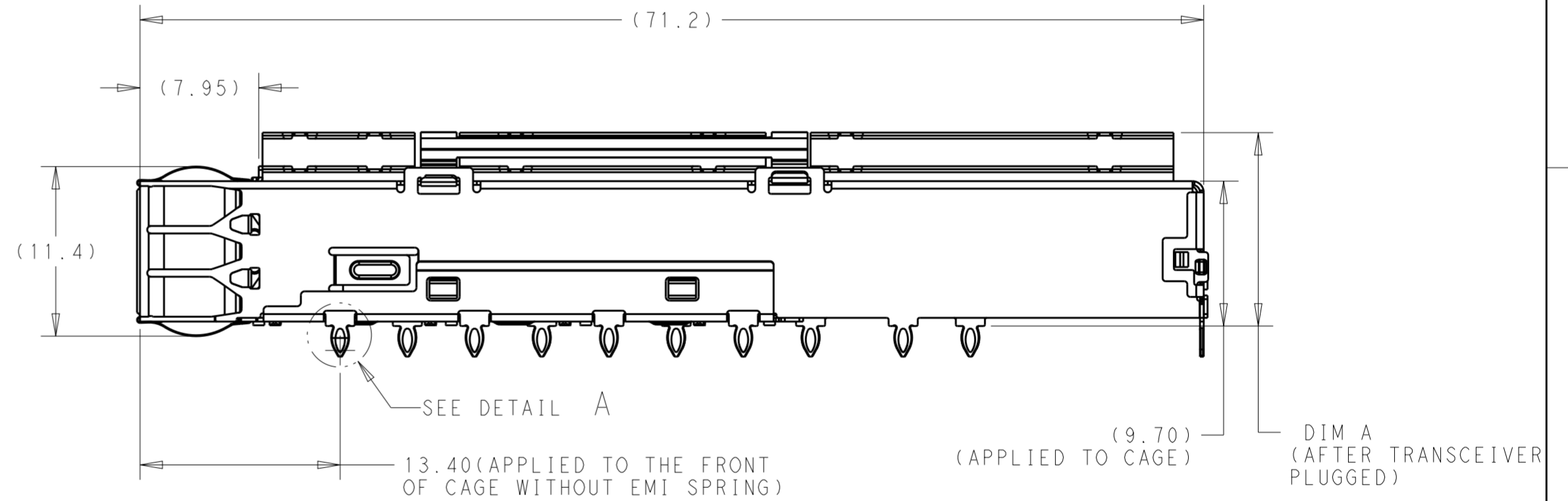
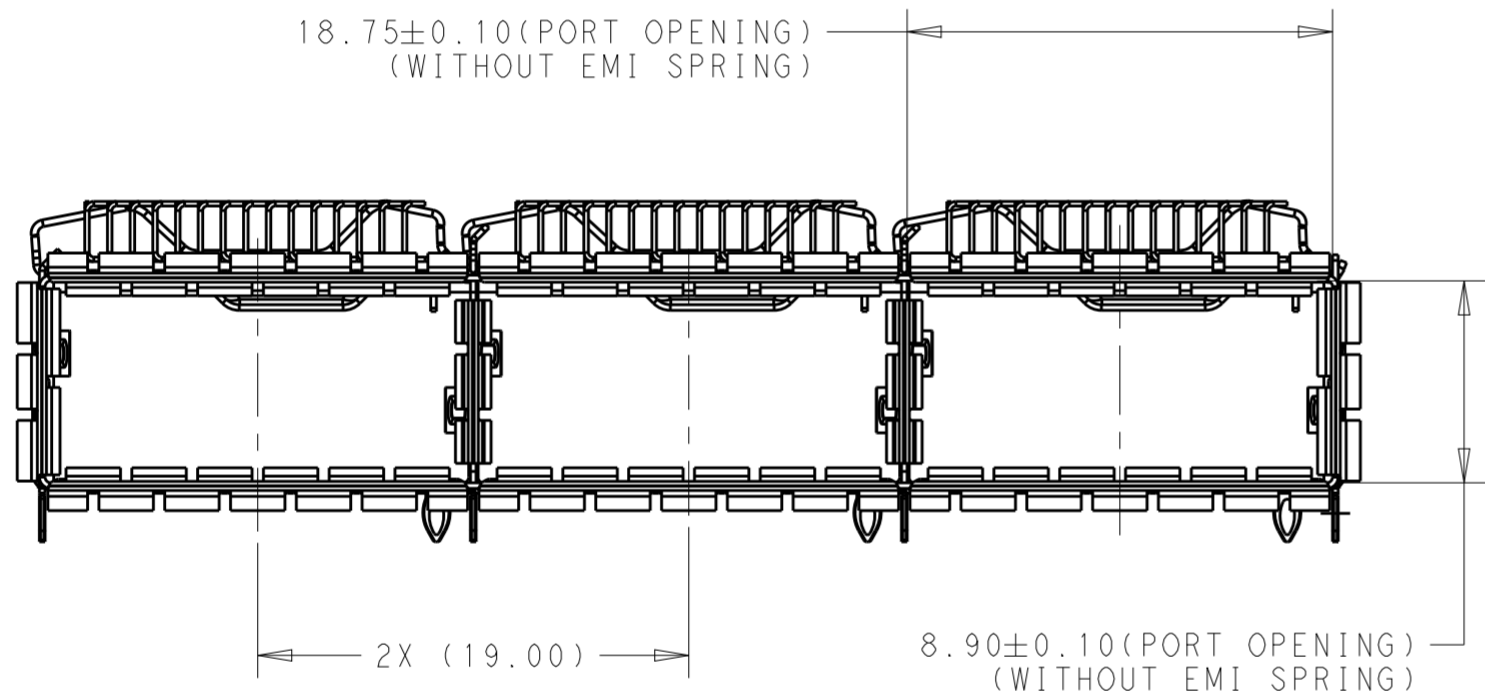

DETAIL A
SCALE 8:1

SCALE 3:1

HS SPECIFICATION	REAR EON	DIM A	PART NUMBER	DESCRIPTION	ITEM
CUSTOMIZED	WITHOUT	16.00	1-2342888-4	CAGE ASSY WITH CUSTOMIZED HS	4
NET	WITH	23.00	2342888-3	CAGE ASSY WITH NET HS	3
SAN	WITH	16.00	2342888-2	CAGE ASSY WITH SAN HS	2
PCI	WITH	13.70	2342888-1	CAGE ASSY WITH PCI HS	1

THIS DRAWING IS A CONTROLLED DOCUMENT.

DWN: STEPHEN HE	22AUG2018	 TE Connectivity	PCB, 1X3 QSFP-DD
CHK: SEAN HAN	05JUL2018		
APVD: SEAN HAN	22AUG2018		
DIMENSIONS: mm TOLERANCES UNLESS OTHERWISE SPECIFIED: 0 PLC ± 0.25 1 PLC ± 0.25 2 PLC ± 0.25 3 PLC ± - 4 PLC ± - ANGLES ± 1 FINISH -		PRODUCT SPEC - APPLICATION SPEC - WEIGHT -	SIZE A2 CAGE CODE - DRAWING NO. 2342888 RESTRICTED TO -
MATERIAL -		CUSTOMER DRAWING	SCALE 1:1 SHEET 1 OF 5 REV A1

THIS DRAWING IS UNPUBLISHED. RELEASED FOR PUBLICATION 20
 © COPYRIGHT 20 BY - ALL RIGHTS RESERVED.

REVISIONS				
P	LTR	DESCRIPTION	DATE	APVD
-		SEE SHEET 1	-	-

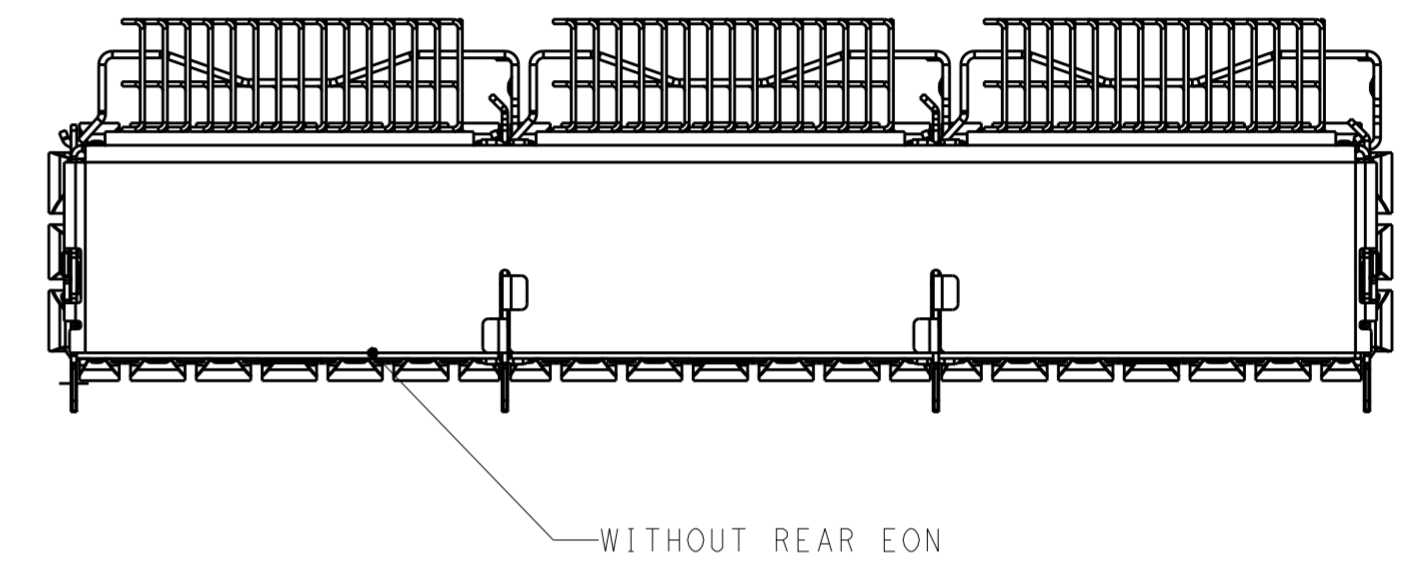
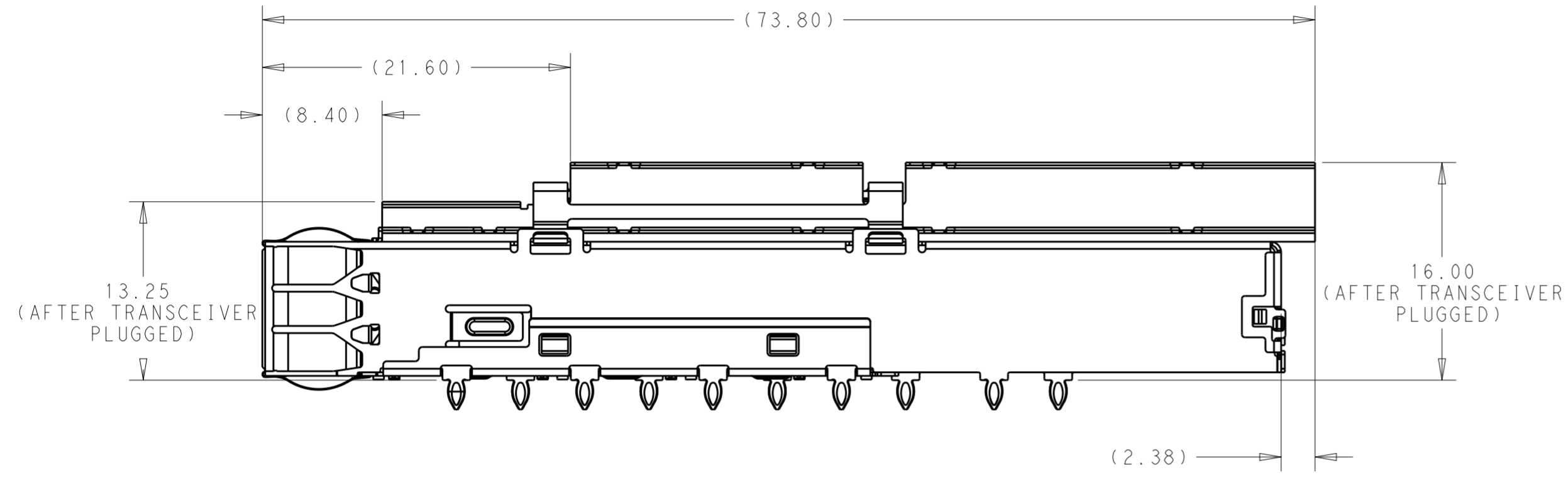



1-2342888-4 AS SHOWN
 SCALE 3:1

THIS DRAWING IS A CONTROLLED DOCUMENT.		DWN 22AUG2018 STEPHEN HE	STE TE Connectivity	
		CHK 05JUL2018 SEAN HAN		
DIMENSIONS: mm		APVD 22AUG2018 SEAN HAN	NAME PCB, 1X3 QSFP-DD	
TOLERANCES UNLESS OTHERWISE SPECIFIED: 0 PLC ± 0.25 1 PLC ± 0.25 2 PLC ± 0.25 3 PLC ± - 4 PLC ± - ANGLES ± 1 FINISH		PRODUCT SPEC - APPLICATION SPEC - WEIGHT -	SIZE A2	CAGE CODE -
MATERIAL -		CUSTOMER DRAWING	DRAWING NO. 2342888	RESTRICTED TO -
		SCALE 1:1	SHEET 2 OF 5	REV A1

THIS DRAWING IS UNPUBLISHED. RELEASED FOR PUBLICATION 20
 © COPYRIGHT 20 BY - ALL RIGHTS RESERVED.

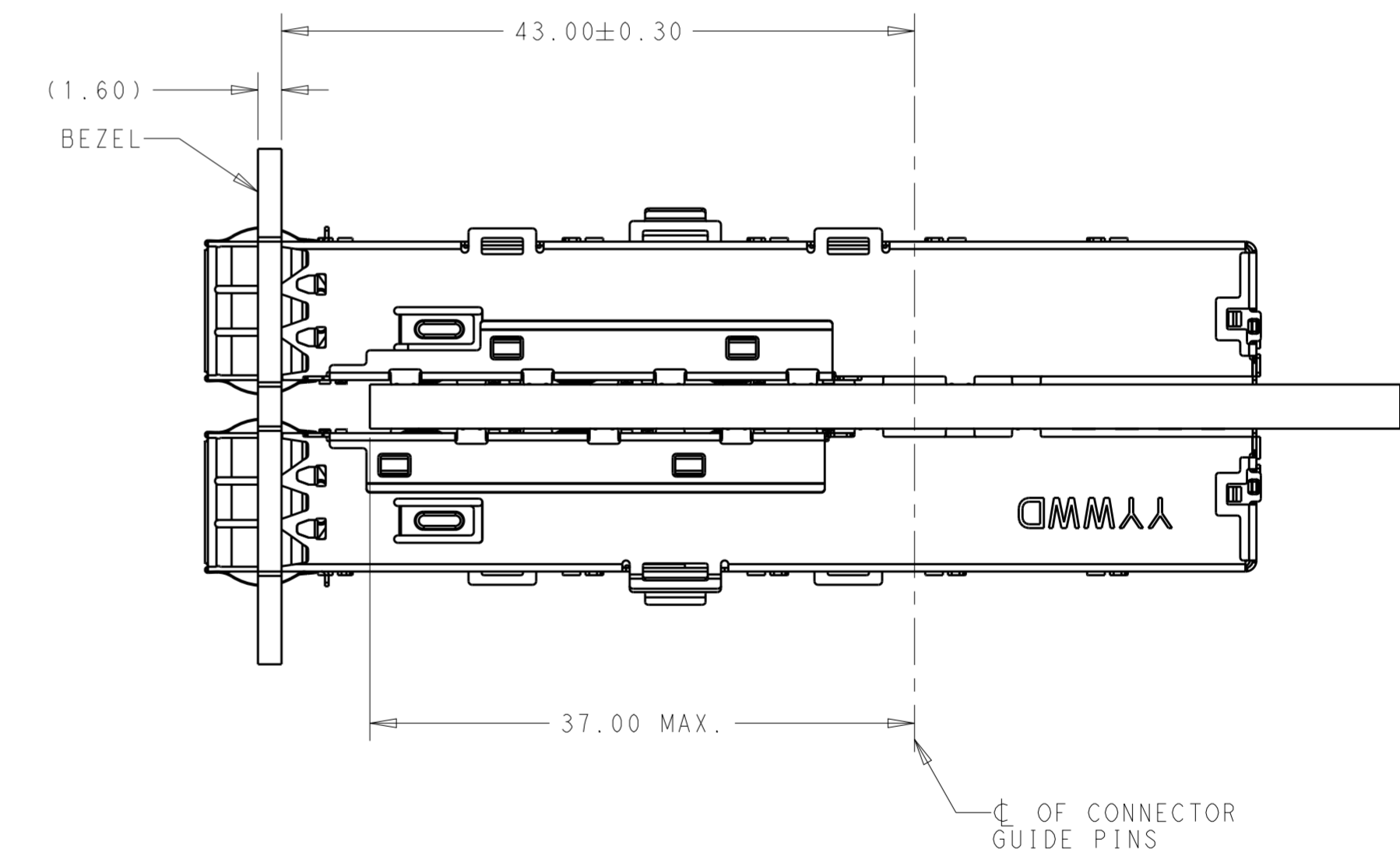
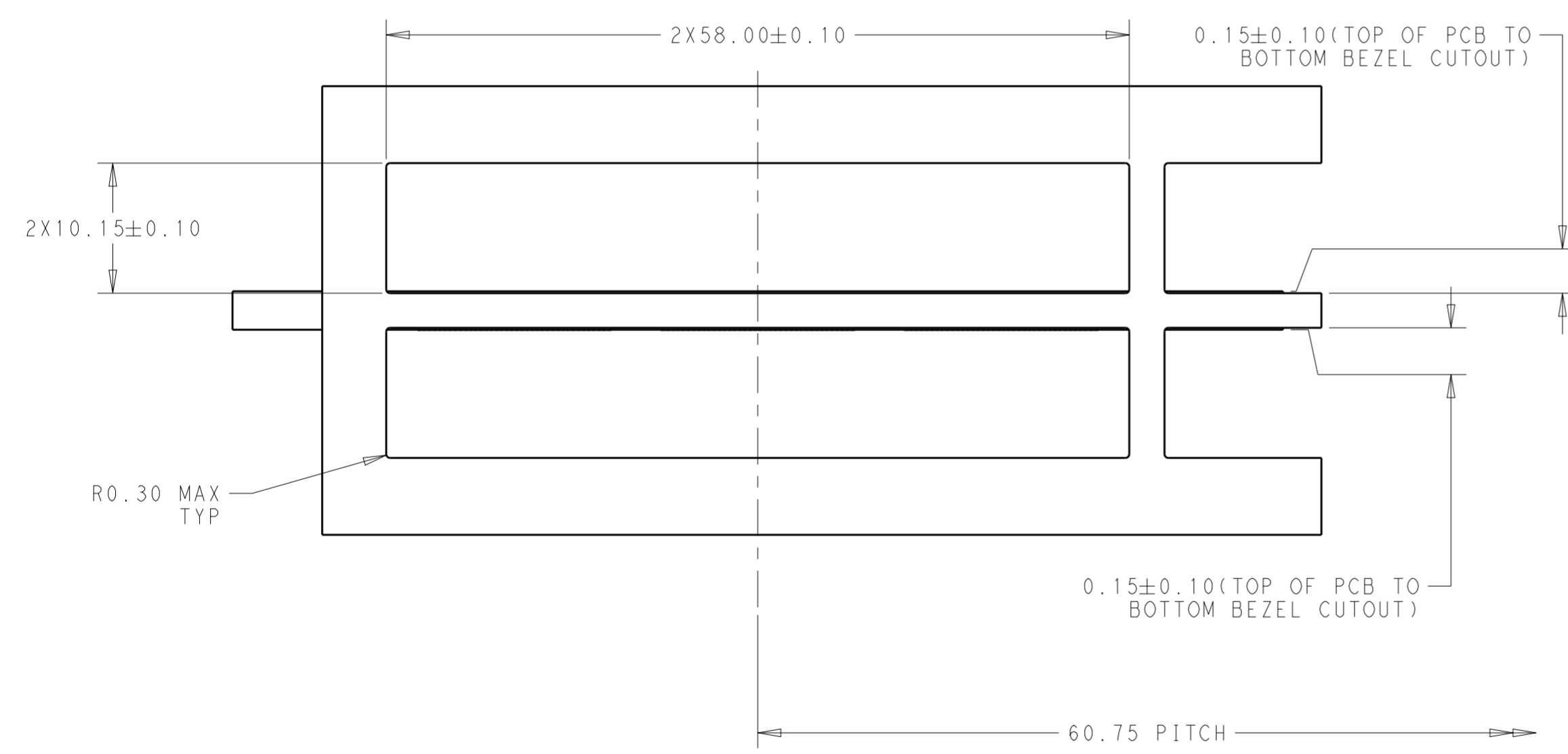
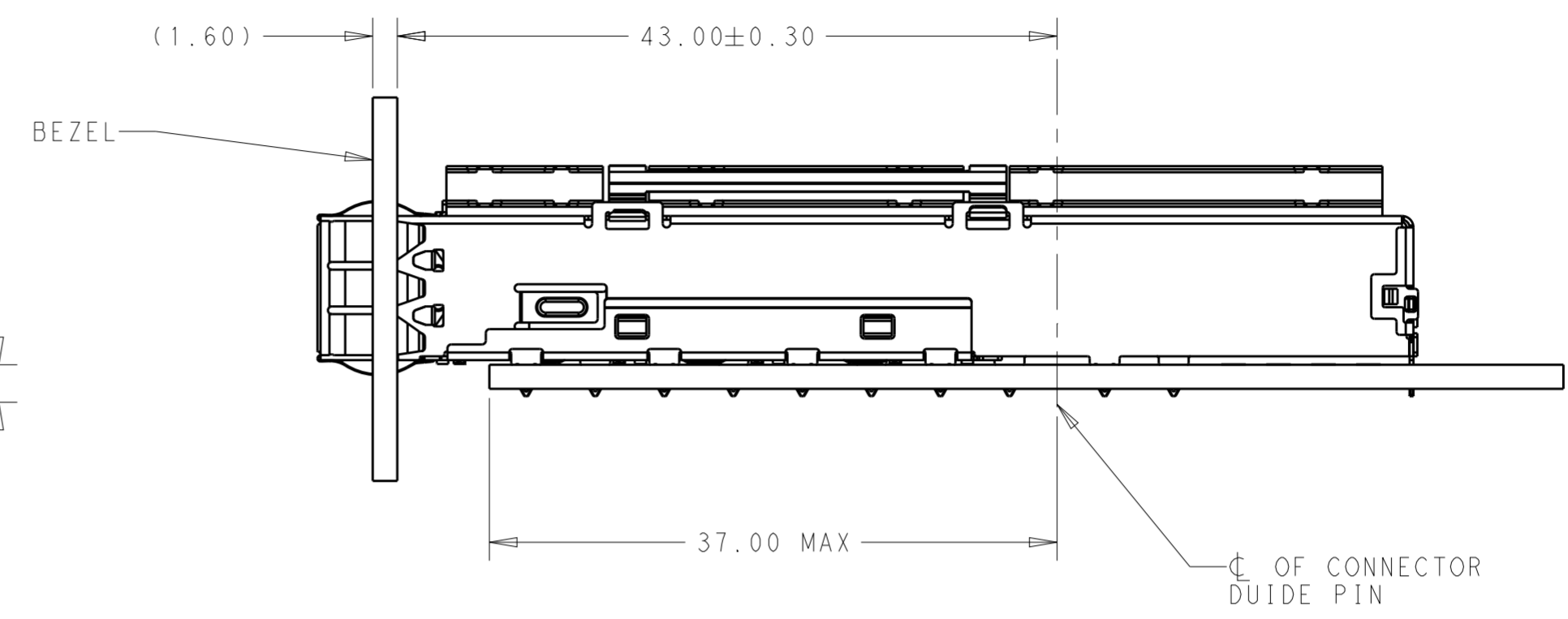
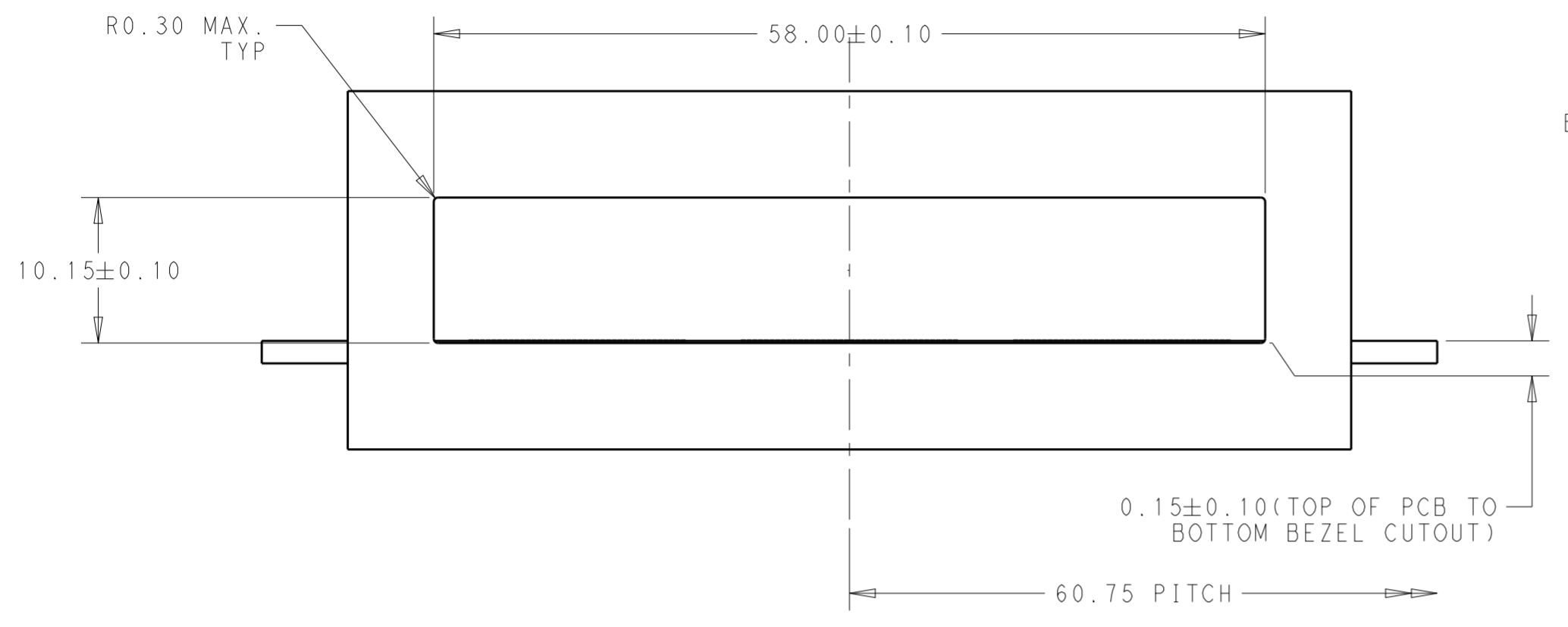
REVISIONS				
P	LTR	DESCRIPTION	DATE	APVD
-	-	SEE SHEET 1	-	-



THIS DRAWING IS A CONTROLLED DOCUMENT.		DWN STEPHEN HE 22AUG2018	 TE Connectivity	
DIMENSIONS: mm		CHK SEAN HAN 05JUL2018		
TOLERANCES UNLESS OTHERWISE SPECIFIED:		APVD SEAN HAN 22AUG2018	NAME PCB, 1X3 QSFP-DD	
0 PLC ± 0.25 1 PLC ± 0.25 2 PLC ± 0.25 3 PLC ± - 4 PLC ± - ANGLES ± 1 FINISH -		PRODUCT SPEC -	SIZE A2	
MATERIAL -		APPLICATION SPEC -	CAGE CODE -	DRAWING NO G-2342888
		WEIGHT -	RESTRICTED TO -	
		CUSTOMER DRAWING	SCALE 1:1	SHEET 3 OF 5
			REV A1	

THIS DRAWING IS UNPUBLISHED. RELEASED FOR PUBLICATION 20
 © COPYRIGHT 20 BY - ALL RIGHTS RESERVED.

REVISIONS				
P	LTR	DESCRIPTION	DATE	APVD
-	-	SEE SHEET 1	-	-

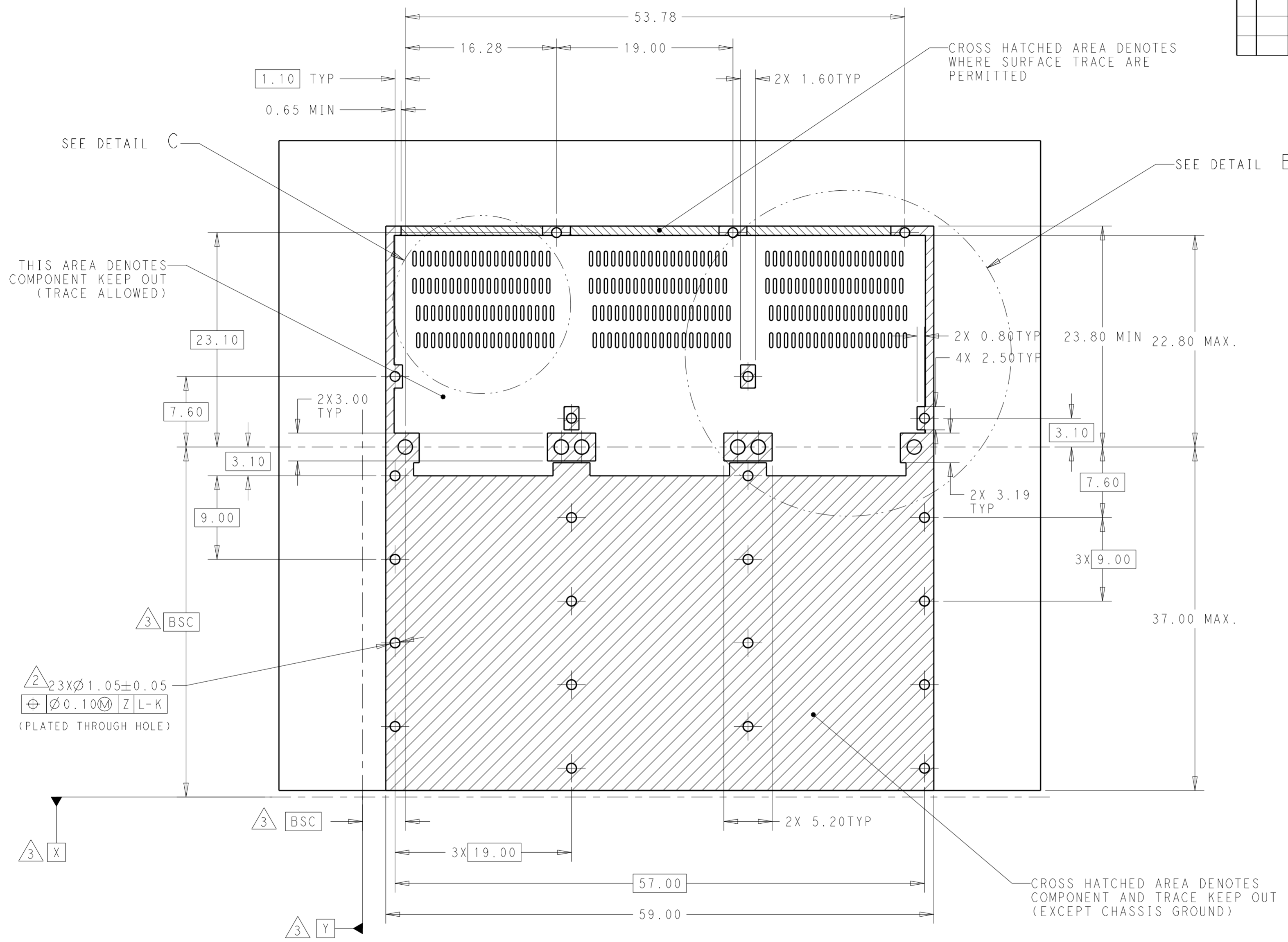

2 23XØ1.05±0.05
 Ø0.10 M Z L-K
 (PLATED THROUGH HOLE)

THIS DRAWING IS A CONTROLLED DOCUMENT.		DWN 22AUG2018 STEPHEN HE	STE TE Connectivity
		CHK 05JUL2018 SEAN HAN	
DIMENSIONS: mm		APVD 22AUG2018 SEAN HAN	NAME PCB, 1X3 QSFP-DD
TOLERANCES UNLESS OTHERWISE SPECIFIED: 0 PLC ± 0.25 1 PLC ± 0.25 2 PLC ± 0.25 3 PLC ± - 4 PLC ± - ANGLES ± 1 FINISH -		PRODUCT SPEC - APPLICATION SPEC - WEIGHT -	SIZE A2 CAGE CODE - DRAWING NO. C-2342888 RESTRICTED TO -
MATERIAL -		CUSTOMER DRAWING	SCALE 1:1 SHEET 4 OF 5 REV A1

THIS DRAWING IS UNPUBLISHED. RELEASED FOR PUBLICATION 20
 © COPYRIGHT 20 BY - ALL RIGHTS RESERVED.

REVISIONS				
P	LTR	DESCRIPTION	DATE	APVD
-	-	SEE SHEET 1	-	-

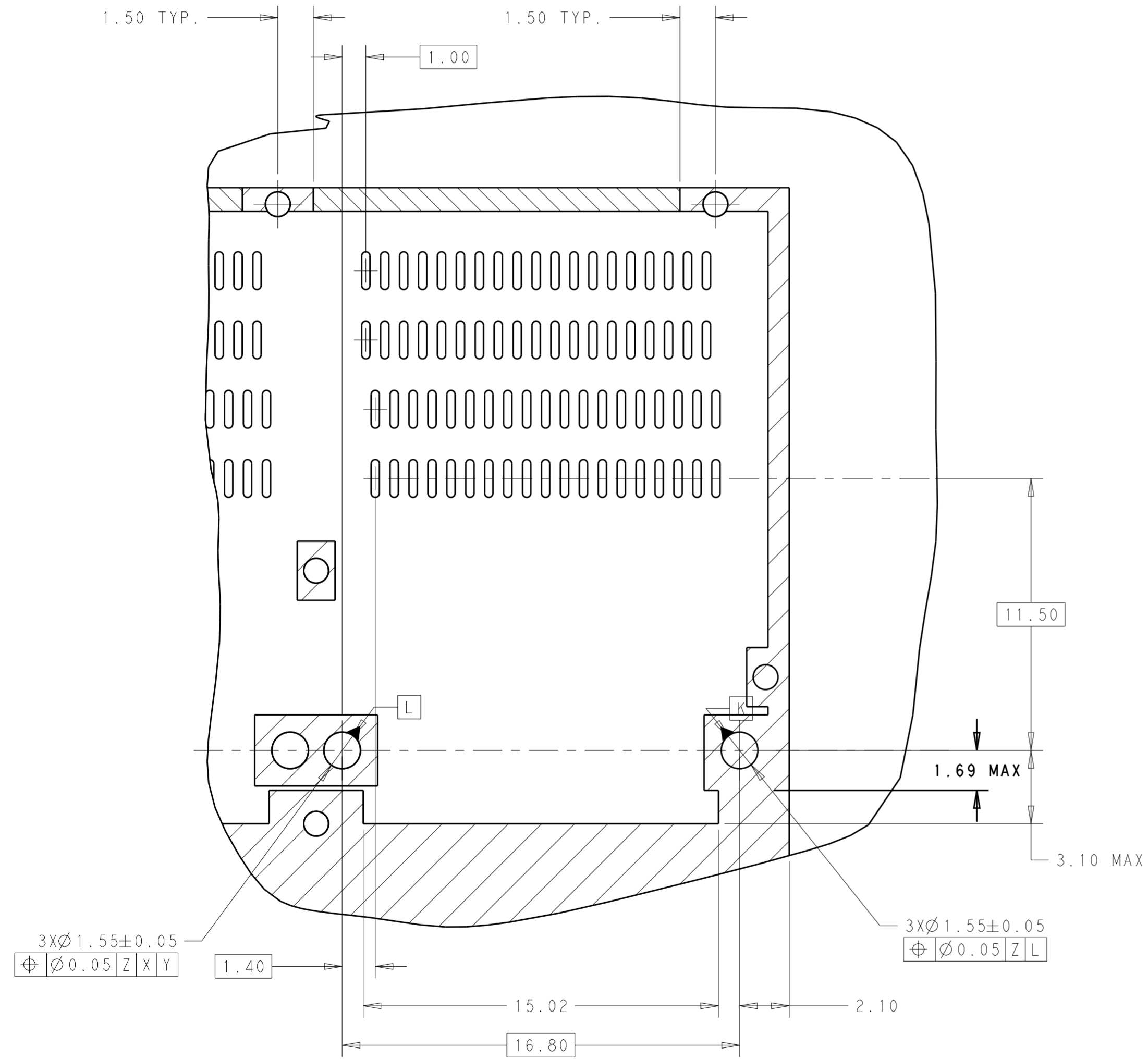

DETAIL B
 SCALE 6:1

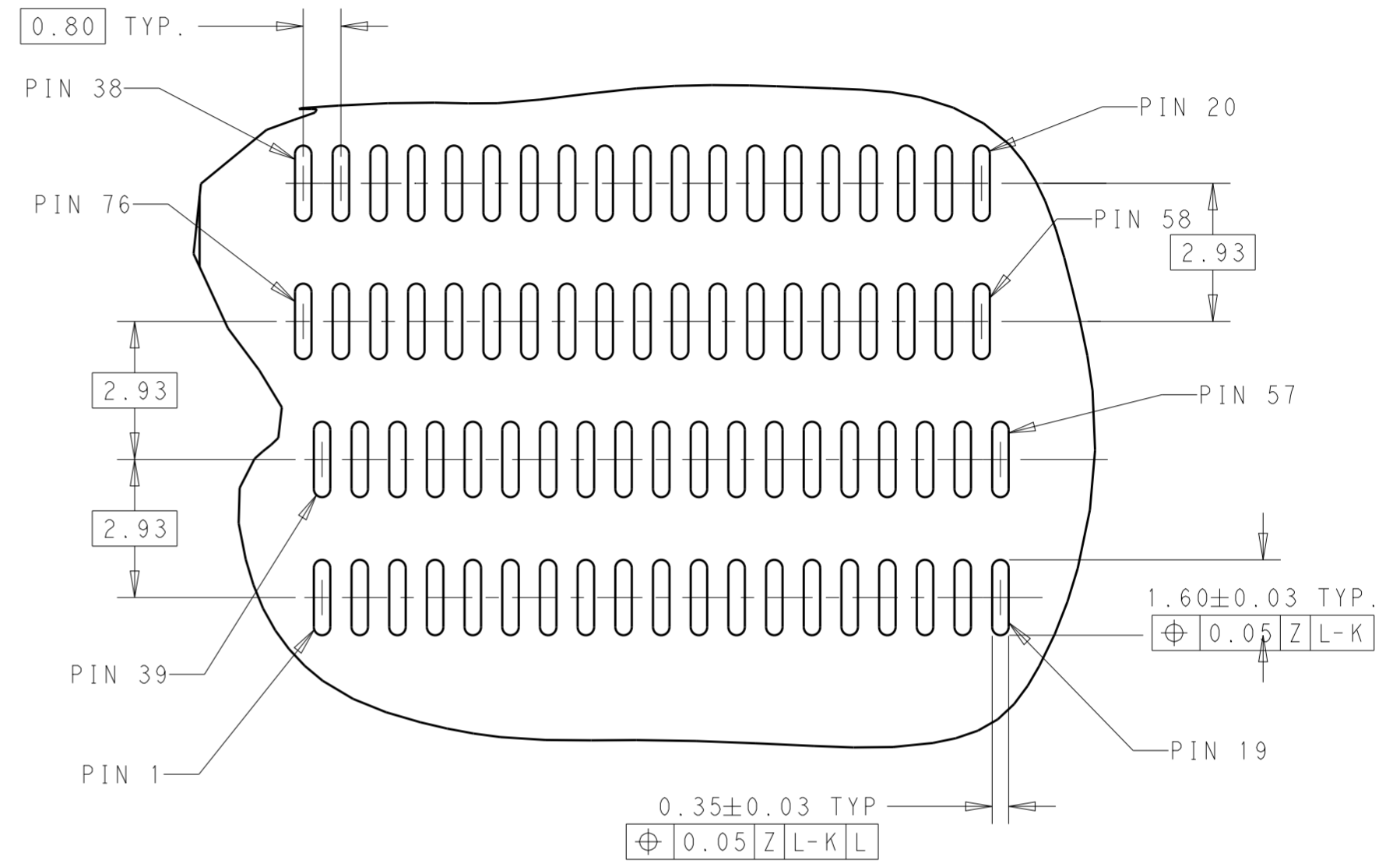

DETAIL C
 SCALE 8:1

THIS DRAWING IS A CONTROLLED DOCUMENT.		DWN 22AUG2018 STEPHEN HE	STE TE Connectivity	
		CHK 05JUL2018 SEAN HAN		
DIMENSIONS: mm		APVD 22AUG2018 SEAN HAN	NAME PCB, 1X3 QSFP-DD	
TOLERANCES UNLESS OTHERWISE SPECIFIED:		PRODUCT SPEC	SIZE A2	
0 PLC ± 0.25		APPLICATION SPEC	CAGE CODE -	
1 PLC ± 0.25		WEIGHT -	DRAWING NO. 2342888	
2 PLC ± 0.25		CUSTOMER DRAWING	RESTRICTED TO -	
3 PLC ± -		SCALE 1:1	SHEET 5 OF 5	
4 PLC ± -			REV A1	
ANGLES ± 1				
FINISH -				