

MAXIM

MAX3795 Evaluation Kit

General Description

The MAX3795 evaluation kit (EV kit) is an assembled demonstration board that provides complete optical and electrical evaluation of the MAX3795 VCSEL driver. The output of the EV kit is interfaced to an SMA connector that can be connected to a 50Ω terminated oscilloscope. A site for a common cathode VCSEL is provided to allow optical testing.

Features

- ◆ Fully Assembled and Tested
- ◆ Single +3.3V Power Supply Operation
- ◆ Allows Optical and Electrical Evaluation

Ordering Information

PART	TEMP RANGE	IC-PACKAGE
MAX3795EVKIT	-40°C to +85°C	24 Thin QFN

Component List

DESIGNATION	QTY	DESCRIPTION
C1, C2, C4-C9, C11-C13, C15-C17	14	0.01μF ±10% ceramic capacitor (0402)
C3	1	0.047μF ±10% ceramic capacitor (0402)
C10	1	OPEN
C14	1	10μF ceramic capacitor (0805)
C18	1	10μF ±10% tantalum capacitor, case B
C19, C20	2	OPEN*
D1	1	VCSEL laser and photodiode*
D2	1	LED, red T1 package
J1-J7	7	SMA connectors, tab contact, Johnson 142-0701-851
JU1-JU7, JU10, JU12-JU13	11	2-pin header, 0.1in centers
JU14	1	3-pin header, 0.1in centers
None	12	Shunts
L1-L3	3	Ferrite Bead, Murata BLM18HD102SN1 (0603)
L4	1	1.2μH inductor (1008LS) Coilcraft 1008CS-122XKBC
Q1, Q2	2	NPN transistor (SOT23) Zetex FMMT491A

DESIGNATION	QTY	DESCRIPTION
R1, R15	2	50kΩ variable resistor Bourns 3296W
R2	1	10kΩ variable resistor Bourns 3296W
R14	1	20kΩ variable resistor Bourns 3296W
R16	1	500kΩ variable resistor Bourns 3296W
R3	1	402Ω ±1% resistor (0402)
R4	1	2.49kΩ ±1% resistor (0402)
R5, R12	2	499Ω ±1% resistor (0402)
R6, R13, R28	3	10.0kΩ ±1% resistor (0402)
R7, R10	2	OPEN*
R8	1	4.75kΩ ±1% resistor (0402)
R9, R11	2	49.9Ω ±1% resistor (0402)
R26	1	10Ω ±1% resistor (0402)
R27	1	1.0kΩ ±1% resistor (0402)
R34	1	1.0kΩ ±1% resistor (0402)
R35	1	15kΩ ±1% resistor (0402)
R36	1	1.69kΩ ±1% resistor (0402)
R51, R53, R56-57	4	806Ω ±1% resistor (0402)
TP1-TP3, TP5 TP6-9, TP11-12, TP13-15, TP20-21	15	Test Point
U1	1	MAX3795ETG (24 QFN)
U2	1	MAX495 (8 SO)

*These components are not supplied but can be populated if the user wants to test a VCSEL.

Evaluates: MAX3795

For pricing, delivery, and ordering information, please contact Maxim/Dallas Direct! at 1-888-629-4642, or visit Maxim's website at www.maxim-ic.com.

MAX3795 Evaluation Kit

Component Suppliers

SUPPLIER	PHONE	FAX
AVX	803-946-0690	803-626-3123
Coilcraft	847-639-6400	847-639-1469
Murata	814-237-1431	814-238-0490
Zetex	516-543-7100	516-864-7630

Note: Please indicate that you are using the MAX3795 when contacting these component suppliers.

Quick Start

Electrical Evaluation

In the electrical configuration, an automatic power control (APC) test circuit is included to emulate a semiconductor laser with a monitor photodiode. Monitor diode current is provided by transistor Q1, which is controlled by an operational amplifier (U2). The APC test circuit, consisting of U2 and Q1, applies the simulated monitor diode current to the MD pin of the MAX3795. To ensure proper operation in the electrical configuration, set up the evaluation board as follows:

- 1) Place shunts on JU4, JU5, JU6, JU7, JU10, JU13 and JU14 (Refer to Table 1 for details).
- 2) Remove shunts JU1 and JU2 (Refer to table 1 for detail).
- 3) To enable the outputs, connect TX_DISABLE to GND by placing a shunt on JU3.

Note: When performing the following resistance checks auto ranging DMMS may forward bias the on-chip ESD protection and cause inaccurate measurements. To avoid this manually set the DMM to a high range.

- 4) Adjust R15, the R_{BIASSET} potentiometer, for 2.5kΩ resistance between TP14 (BIASSET) and ground.
- 5) Adjust R1, the R_{PWRSET} potentiometer, for 10kΩ resistance between TP2 (REF) and TP12 (MD).
- 6) Remove JU12 or Adjust R14, the R_{PEAKSET} potentiometer, for 20kΩ resistance between TP15 (PEAKSET) and ground, to disable peaking.
- 7) Adjust R16, the R_{TC} potentiometer, for 0Ω resistance between TP7 (TC1) and TP8 (TC2), to disable temperature compensation.
- 8) Adjust R2, the R_{MODSET} potentiometer, for 10kΩ resistance between TP9 (MODSET) and ground.

- 9) Apply a differential input signal (250mV_{P-P} to 2400mV_{P-P}) between SMA connectors J5 and J7 (IN+ and IN-).
- 10) Attach a high-speed oscilloscope with a 50Ω input to the SMA connector J6 (OUT).
- 11) Connect a +3.3V supply between TP20 (V_{CC}) and TP21 (GND). Set the current limit to about 200mA. Adjust the power supply until the voltage between TP11 and ground is +3.3V.
- 12) Adjust R1 (R_{PWRSET}) until desired laser bias current is achieved.

$$I_{BIAS} = \frac{V_{JU5}}{49.9\Omega}$$

- 13) The MD and BIAS currents can be monitored at TP1 (V_{PWRMON}) and TP3 (V_{BIASMON}) using the equations below:

$$I_{MD} = \frac{V_{PWRMON}}{2 * R_{PWRSET}}$$

$$I_{BIAS} = \frac{9 * V_{BIASMON}}{402\Omega}$$

Note: If the voltage at TP1 exceeds V_{PMTH} (typical 0.8V) or TP3 exceeds V_{BMTH} (typical 0.8V), the FAULT signal will be asserted and latched.

- 14) Adjust R2 until the desired laser modulation current is achieved.

$$I_{MOD} = \frac{\text{Signal Amplitude (V)}}{50\Omega}$$

- 15) If peaking is desired, Install JU12. Adjust R14 (R_{PEAKSET}) until the desired amount of peaking is achieved.

Optical Evaluation

For optical evaluation of the MAX3795, configure the evaluation kit as follows:

- 1) Place shunts on JU2, JU6, JU7, JU13 and JU14 (Refer to Table 1 for details).
- 2) Remove components L2 and C9. Remove the shunts from JU1, JU4 and JU5.

MAX3795 Evaluation Kit

Evaluates: MAX3795

- 3) Install a 0Ω resistor at R7 to connect the anode of the VCSEL to the output.
- 4) To enable the outputs, connect TX_DISABLE to GND by placing a shunt on JU3.
- 5) Connect a common cathode VCSEL as shown in figure 1. Keep leads short to reduce reflection.

Note: When performing the following resistance checks auto ranging DMMS may forward bias the on-chip ESD protection and cause inaccurate measurements. To avoid this manually set the DMM to a high range.

- 6) Adjust R15, the R_{BIASSET} potentiometer, for 2.5kΩ resistance between TP14 (BIASSET) and ground.
- 7) Adjust R1, the R_{PWRSET} potentiometer, for 10kΩ resistance between TP2 (REF) and TP12 (MD).
- 8) Open JU12 or adjust R14, the R_{PEAKSET} potentiometer, for 20kΩ resistance between TP10 (PEAKSET) and ground, to disable peaking.
- 9) Adjust R16, the R_{TC} potentiometer, for 0Ω resistance between TP7 (TC1) and TP8 (TC2), to disable temperature compensation.
- 10) Adjust R2, the R_{MODSET} potentiometer, for 10kΩ resistance between TP9 (MODSET) and ground.
- 11) Apply a differential input signal (250mV_{P-P} to 2400mV_{P-P}) between SMA connectors J5 and J7 (IN+ and IN-).
- 12) Attach the VCSEL fiber connector to an optical/electrical converter.
- 13) Connect a +3.3V supply between TP20 (V_{CC}) and TP21 (GND). Set the current limit to

200mA. Adjust the power supply until the voltage between TP11 and ground is +3.3V.

- 14) Adjust R1 (R_{PWRSET}) until desired average optical power is achieved.
- 15) The MD and BIAS currents can be monitored at TP1 (V_{PWRMON}) and TP3 (V_{BIASMON}) using the equations below:

$$I_{MD} = \frac{V_{PWRMON}}{2 * R_{PWRSET}}$$

$$I_{BIAS} = \frac{9 * V_{BIASMON}}{402\Omega}$$

Note: If the voltage at TP1 exceeds V_{PMTH} (typical 0.8V) or TP3 exceeds V_{BMTH} (typical 0.8V), the FAULT signal will be asserted and latched.

- 16) Adjust R2 (R_{MODSET}) until the desired optical amplitude is achieved. Optical amplitude can be observed on an oscilloscope connected to an optical/electrical converter. VCSEL overshoot and ringing may be improved by appropriate selection of R10 and C10.
- 16) The falling edge of the optical waveform may improve with peaking. Install JU12 and adjust R14 (R_{PEAKSET}) until the desired amount of peaking is achieved.

MAX3795 Evaluation Kit

Evaluates: MAX3795

Table 1. Adjustment and Control Descriptions (see Quick Start)

COMPONENT	NAME	FUNCTION
JU1	COMP	Enables/disables the APC circuit. Remove shunt to enable APC circuit.
JU2	PHOTODIODE	Installing a shunt will connect the photodiode of the VCSEL to the MD pin. Used when a VCSEL is installed.
JU3	TX_DISABLE	Enables/disables the output currents. Install a shunt to enable output currents.
JU4	IPD	Determines the gain of the photodiode emulator. When JU4 is open the gain is 0.02 A/A. When JU4 is shunted the gain is 0.12 A/A.
JU5	APC_OPEN	Installing a shunt connects the electrical output of the part to the emulation circuit.
JU6	FAULT	Installing a shunt enables the external fault indicator circuit.
JU7	SQUELCH	Installing a shunt enables the squelch function.
JU10	VCCEXT	Installing a shunt provides power to the emulation and fault indicator circuits.
D2	Fault Indicator	LED is illuminated when a fault condition has occurred (Refer to the Detailed Description section of the MAX3740 data sheet).
R1	R _{PWRSET}	Adjusts transmit optical power to be maintained by the APC loop.
R2	R _{MODSET}	Adjusts the laser modulation current.
R14	R _{PEAKSET}	Adjusts the peaking for the falling edge of the VCSEL.
R15	R _{BIASSET}	In closed-loop configuration it adjusts the maximum bias current available to the APC. In open-loop configuration it adjusts the bias level of the output.
R16	R _{TC}	Adjusts the temperature compensation of the modulation current.

MAX3795 Evaluation Kit

Evaluates: MAX3795

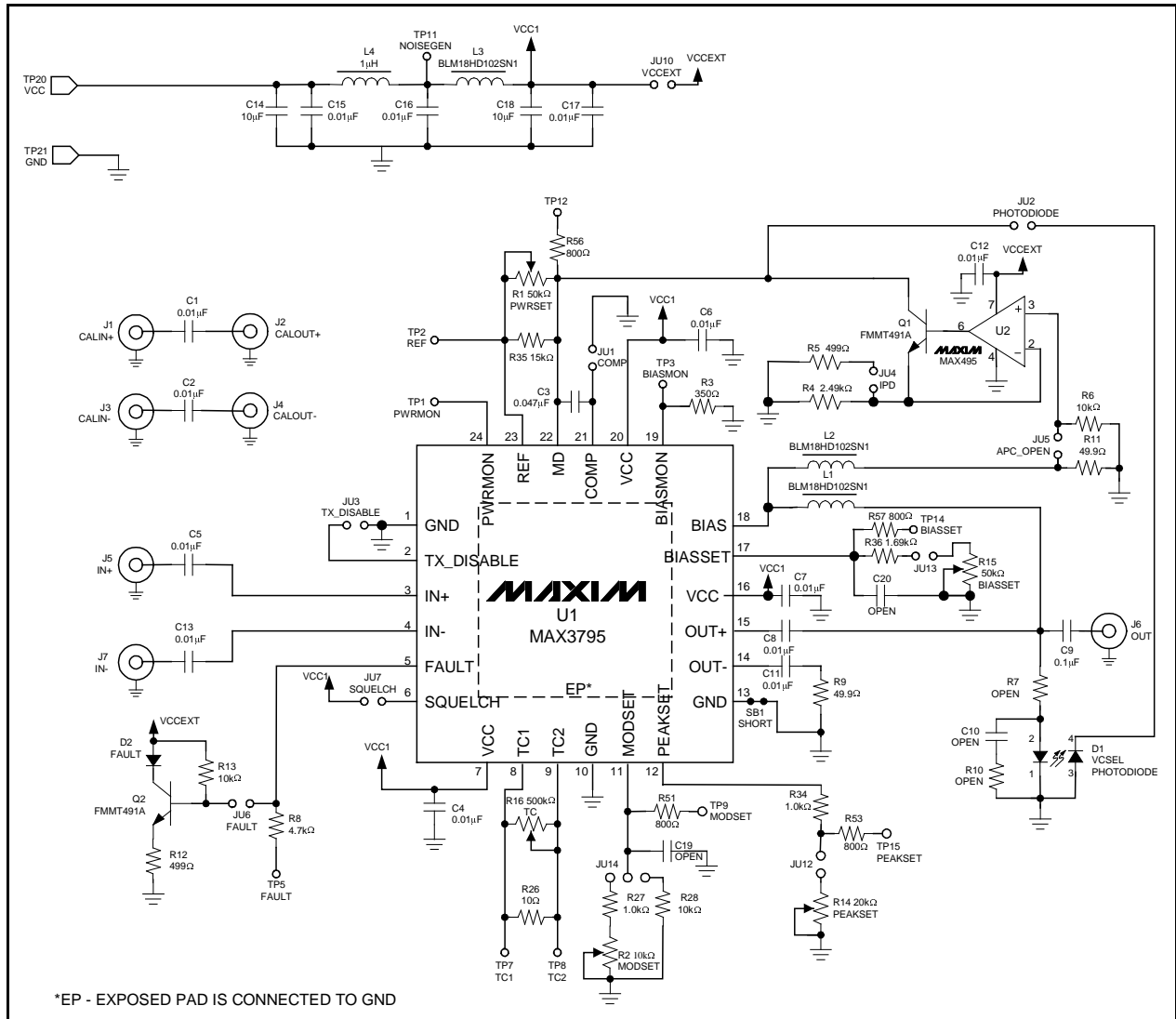

Figure 1. MAX3795 EV Kit Schematic

MAX3795 Evaluation Kit

Evaluates: MAX3795

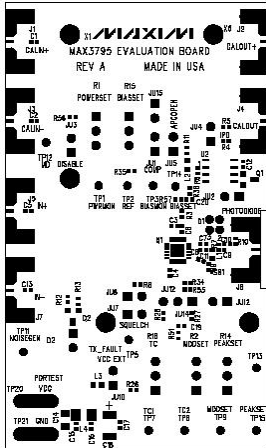

Figure 2. MAX3795 EV Kit PC Component Placement Guide—Component Side

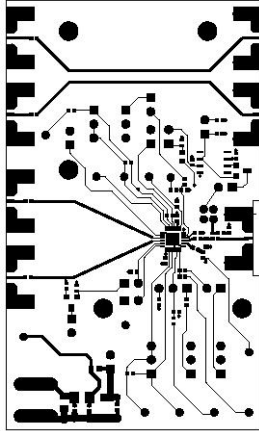

Figure 3. MAX3795 EV Kit PC Board Layout—Component Side



Figure 4. MAX3795 EV Kit PC Board Layout—Ground Plane

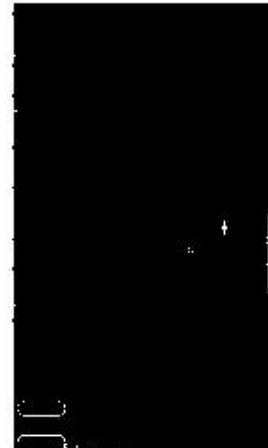

Figure 5. MAX3795 EV Kit PC Board Layout—Power Plane

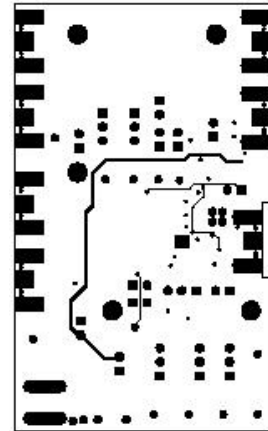

Figure 6. MAX3795 EV Kit PC Board Layout—Solder Side

Maxim cannot assume responsibility for use of any circuitry other than circuitry entirely embodied in a Maxim product. No circuit patent licenses are implied. Maxim reserves the right to change the circuitry and specifications without notice at any time.

Maxim Integrated Products, 120 San Gabriel Drive, Sunnyvale, CA 94086 408-737-7600