

RECOMMENDED PCB LAYOUT

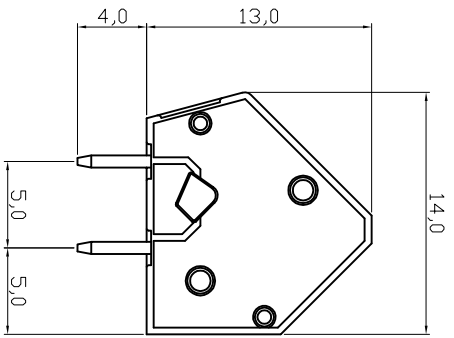
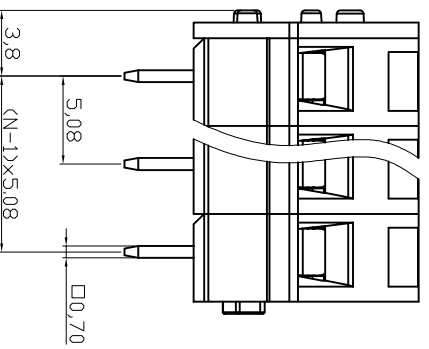

N=Number of contacts

Material

Terminal body (Contact pin): Brass
 Wire guard: Stainless steel
 Surface of solder tail: Tin plated
 Insulator (housing): Thermoplastic (UL94V-0)

Electrical

Voltage rating: 300VAC
 Current rating: 15A
 Wire range:
 Solid wire(AWG): 12-28
 Stranded wire(AWG): 12-28
 Pull force:
 Screw:
 Wire strip length: 6-7mm
 Withstanding Voltage: 1.6KV
 Operating temperature: -40°C to +115°C
 Soldering temperature: 250°C±10°C/5 Sec
 Safety approval : us

RoHS compliant

 File No.: E349947

Scale	1:1
TOLERANCE	
X.	±0.50
X.X	±0.30
X.XX	±0.10
DIM	
X.°	±1°
X.X°	±X°
Angle	TOL

②	Add UL File No.	Winnie	15.03.2016
①	Drawn	Dean	29.07.2009
	Modification		
	Date		
	Name		

	Date	Name
	29.07.2009	Dean
	15.03.2016	Winnie



Customer-No.	
ASSMANN WSW-No.	A-TB508-HGXX
Drawing-No.	ASS 3605 CO
Replace	rev02
Sheet	

1	2	3	4	5	6	7
A	B	C	D	E	F	G
H						