

LOC		DIST		REVISIONS			
REV	BY	DATE	DESCRIPTION	DATE	BY	APPROV	
AJ		16		J	REV PER ECO 08-009474	7/21/2008	DW JL

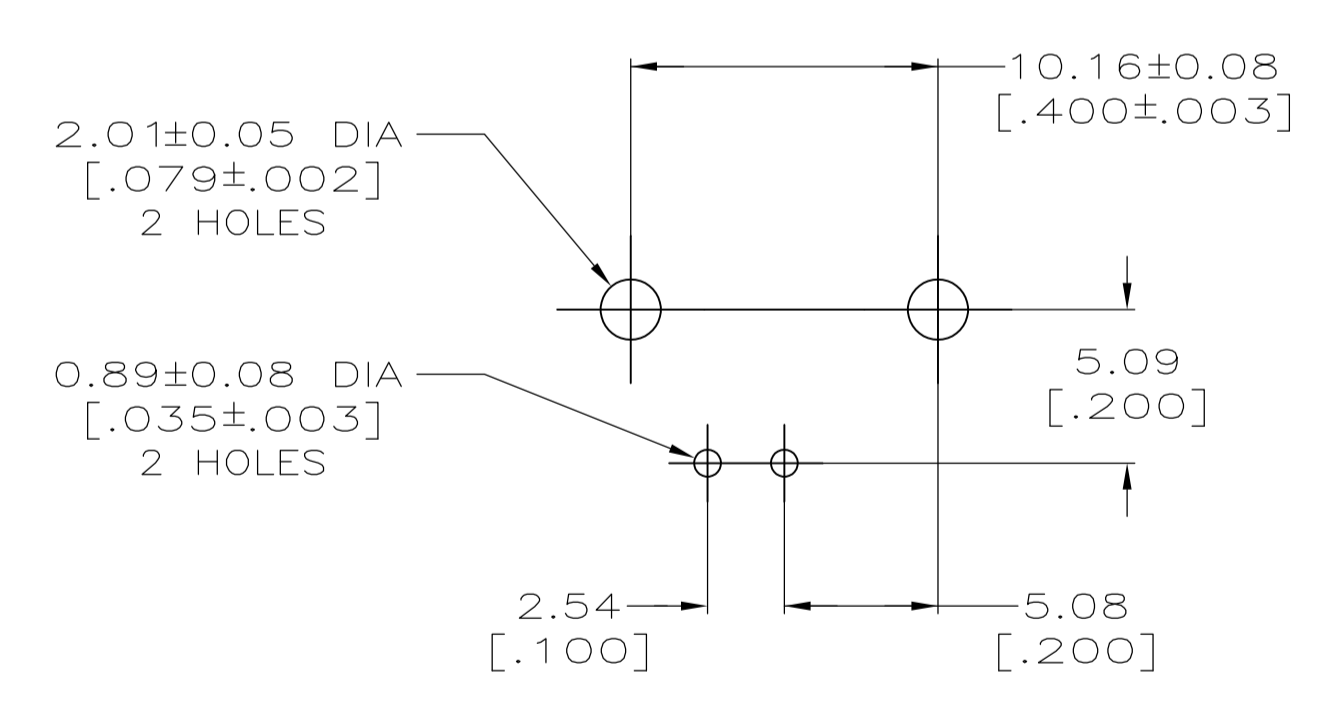
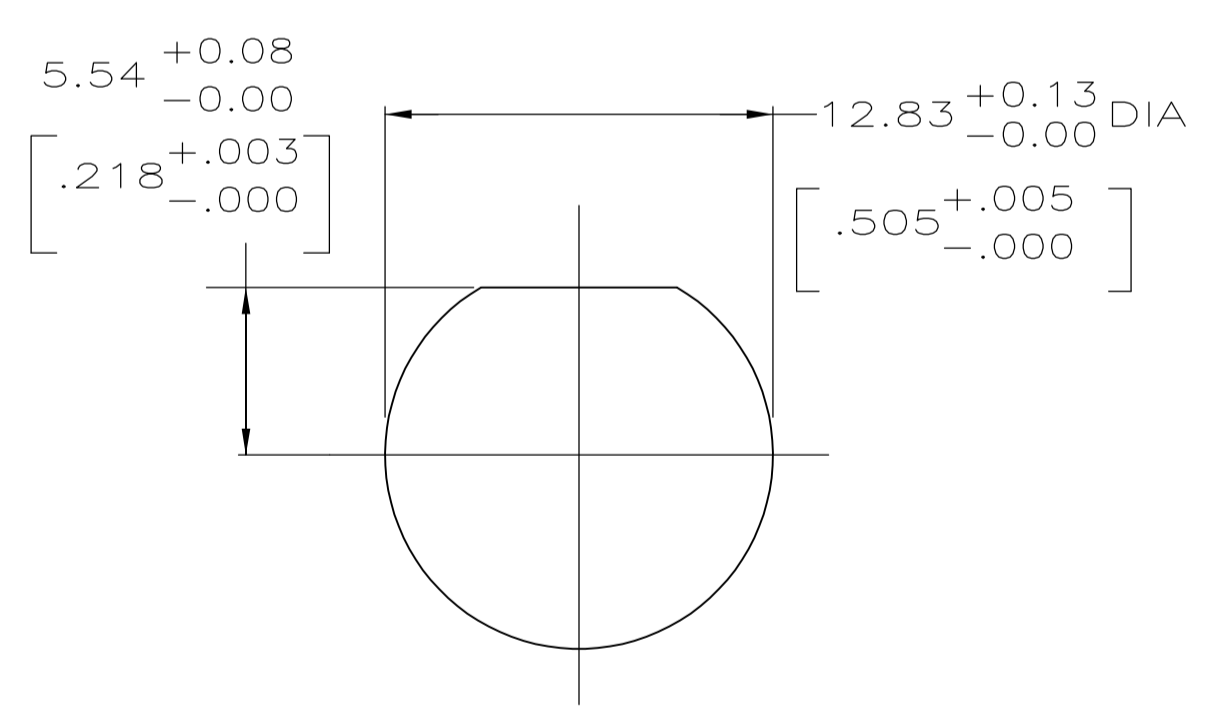
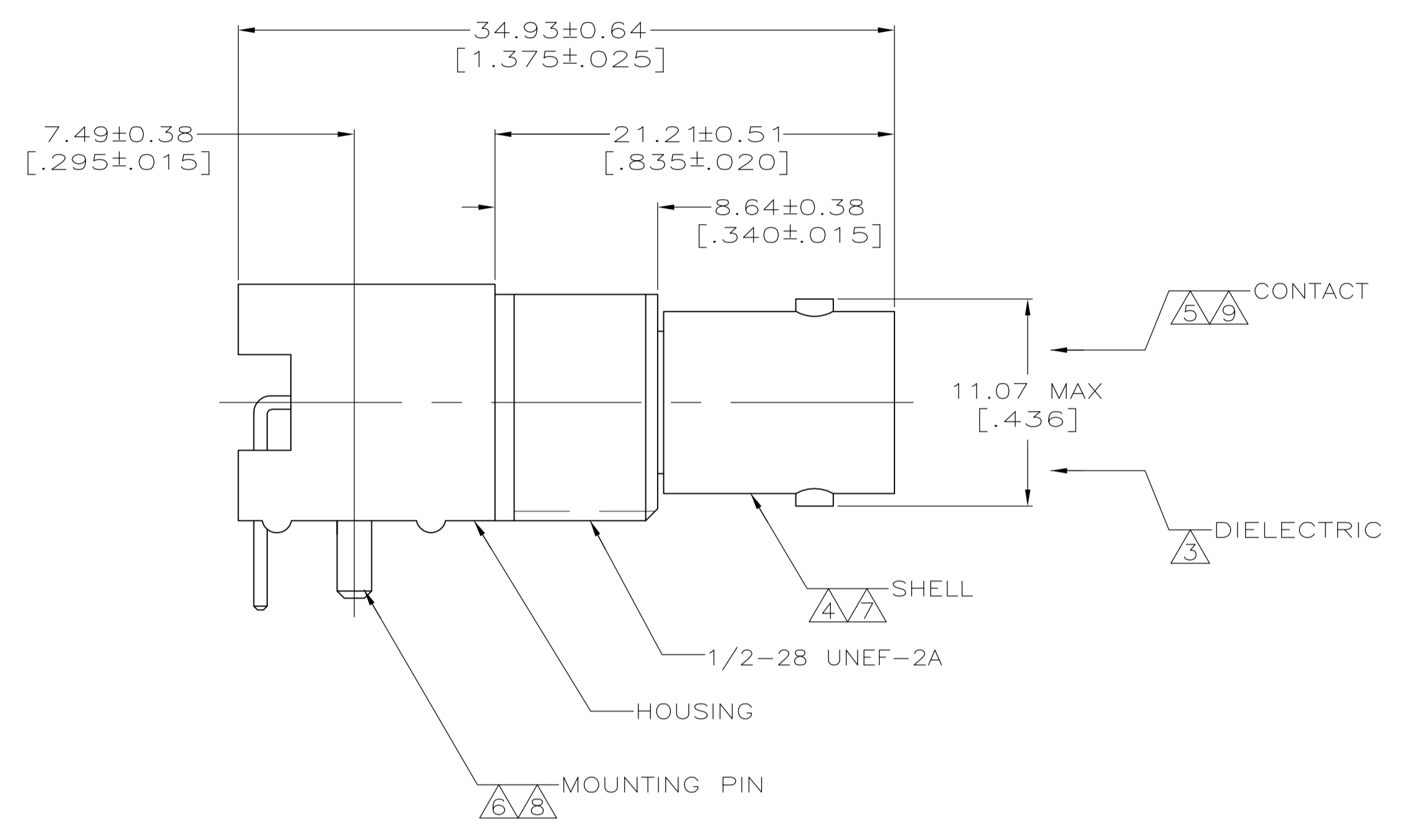
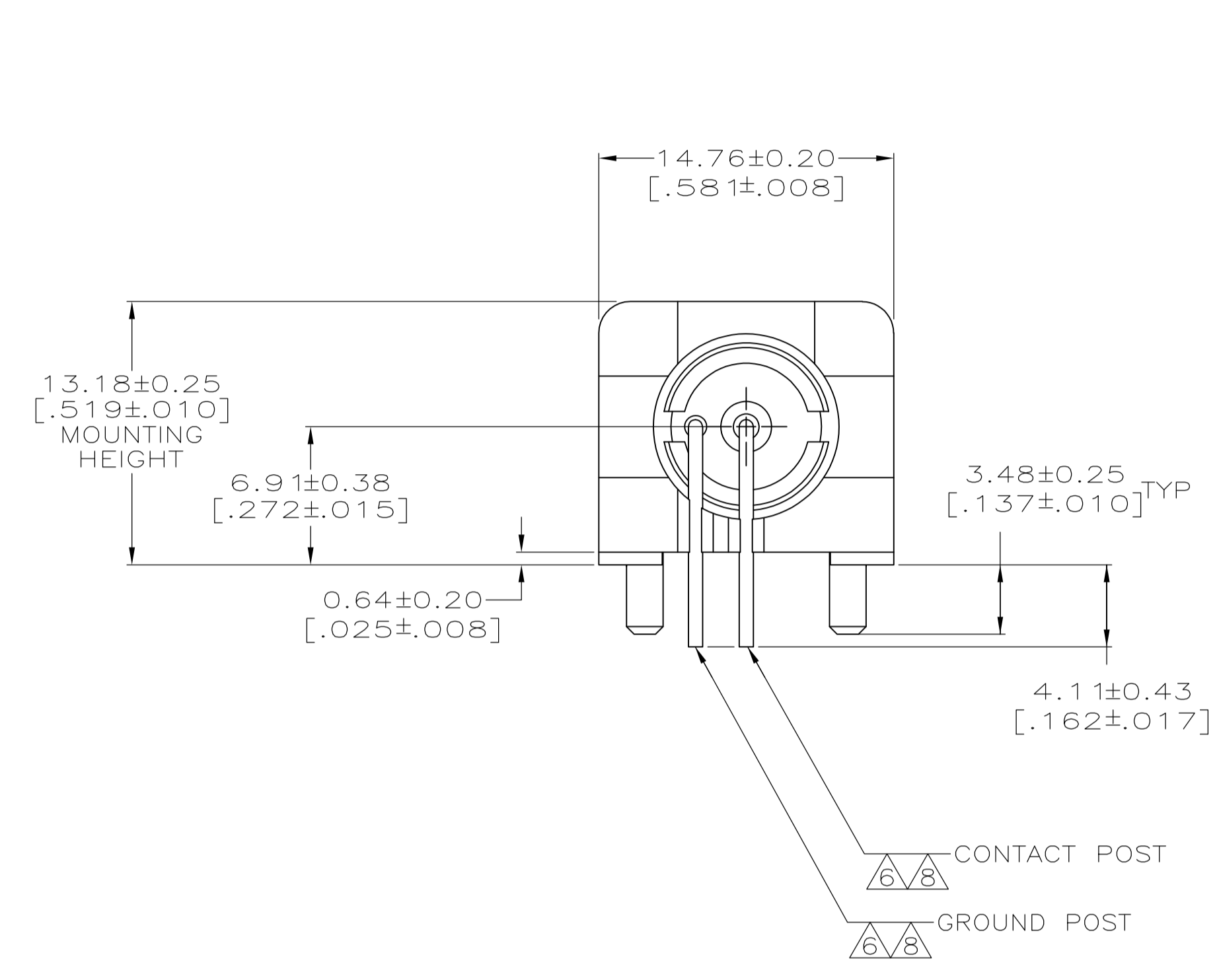

- 1 POLYESTER PBT PER MIL-M-24519, TYPE GPT-15F, UL94V-0 RATED, COLOR:NATURAL
- 2 POLYESTER PBT PER MIL-M-24519, TYPE GPT-15F, UL94V-0 RATED, COLOR:BLACK
- 3 POLYMETHYLPENTENE, GENERAL PURPOSE.
- 4 ZINC PER QQ-Z-363.
- 5 BERYLLIUM COPPER PER QQ-C-530.
- 6 BRASS PER ASTM-B-453.
- 7 NICKEL PLATE PER QQ-N-290 3.81 μm [.000150] MINIMUM THICK.
- 8 TIN PLATE PER ASTM-B-545 3.81 μm [.000150] MINIMUM THICK.
- 9 GOLD PLATE PER MIL-G-45204 0.76 μm [.000030] MINIMUM THICK.
- 10. SEE INSTRUCTION SHEET 2769.

HOUSING MATERIAL	413194-2
	413194-1
	PART NO

THIS DRAWING IS A CONTROLLED DOCUMENT.		DIN 11-29-90		Tyco Electronics Corporation	
DIMENSIONS: INCHES		TOLERANCES UNLESS OTHERWISE SPECIFIED:		Tyco Electronics	
0 PLC ± -		1 PLC ± -		Tyco Electronics Corporation	
1 PLC ± -		2 PLC ± 0.06 [.002]		Middletown, PA 17057	
2 PLC ± -		3 PLC ± -		NAME JACK, RIGHT ANGLE, PCB, 75 OHM, BNC	
3 PLC ± -		4 PLC ± -		SIZE CAGE CODE DRAWING NO	
4 PLC ± -		ANGLES ± -		A1 00779 C=413194	
MATERIAL SEE NOTES 1-6		FINISH SEE NOTES 7-9		RESTRICTED TO	
CUSTOMER DRAWING		SCALE 4:1		SHEET 1 OF 1 REV J	