

# User's Guide

## BQ2573X Evaluation Module



### ABSTRACT

The BQ25730EVM and BQ25731EVM evaluation modules (EVM) are I<sup>2</sup>C-controlled NVDC-1 buck boost charger. The input voltage range is between 3.5 V and 26 V, with a programmable output of 1–5 cells and a charge output current range of 128 mA to 15 A. This EVM does not include the EV2400 interface device. The EV2400 must be ordered separately to evaluate the BQ2573X EVM.

### Table of Contents

<b>1 Introduction</b> .....	2
1.1 EVM Features.....	2
1.2 General Description.....	2
<b>2 Test Summary</b> .....	5
2.1 Definitions.....	5
2.2 Equipment.....	5
2.3 Equipment Setup.....	6
2.4 Procedure.....	9
<b>3 Bill of Materials, Board Layout, and Schematics</b> .....	10
3.1 Bill of Materials.....	10
3.2 Board Assembly Layout.....	13
3.3 Schematic.....	19
<b>Revision History</b> .....	21

### List of Figures

Figure 2-2. Original Test Setup for BMS051 (BQ2573X EVM).....	7
Figure 2-3. BQ2573X Evaluation Software Main Window.....	8
Figure 2-4. EN_OTG.....	9
Figure 3-1. Top Assembly.....	13
Figure 3-2. Bottom Assembly.....	14
Figure 3-3. PCB Layer 1.....	15
Figure 3-4. PCB Layer 2.....	16
Figure 3-5. PCB Layer 3.....	17
Figure 3-6. PCB Layer 4.....	18
Figure 3-7. BQ25730 EVM Schematic.....	19
Figure 3-8. BQ25731 EVM Schematic.....	20

### List of Tables

Table 1-1. I/O Description.....	2
Table 1-2. Controls and Key Parameters Setting.....	3
Table 1-3. Recommended Operating Conditions.....	4
Table 3-1. BQ2573X EVM Bill of Materials.....	10

### Trademarks

USB Type-C™ is a trademark of USB Implementer's Forum, Inc..  
All trademarks are the property of their respective owners.

## 1 Introduction

### 1.1 EVM Features

This EVM supports the following features:

- Evaluation module for the BQ2573X devices
- Supports 3.5- to 26-V input source
  - 3.5- to 26-V, 0- to 10-A input operating range and 1–5 cell battery configuration
  - Supports USB2.0, USB 3.0, USB 3.1 ( USB Type-C™) and USB\_PD
  - Supports USB OTG with 3- to 24-V adjustable output
  - Supports Fast Role Swap (FRS) feature for USB\_PD
- Narrow VDC (NVDC) power path management
  - Instant-on works with no battery or deeply discharged battery
  - Battery supplements system when adapter is fully-loaded
- 400-kHz or 800-kHz switching frequency for high efficiency
- Power Path (BQ25730) or Non Power Path (BQ25731) options
- Power and Current Monitor for CPU Throttling
- Safety
  - Thermal shutdown
  - Input and system overvoltage protection
  - MOSFET overcurrent protection
- Charge status outputs for LED or host processor
- Maximum power tracking capability by input voltage regulation
- Test points for key signals available for testing purposes. Easy probe hook-up.
- Jumpers available. Easy-to-change connections.

### 1.2 General Description

The BQ2573X evaluation modules are complete charger modules for evaluating an I<sup>2</sup>C-controlled buck boost charge using the BQ2573X devices.

The BQ2573X EVM does not include the EV2400 interface board. To evaluate the BQ2573X EVM, order an EV2400 interface board separately.

The BQ2573X is a synchronous NVDC-1 battery buck boost charge controller, offering a low component count, high efficiency solution for space-constrained, multi-chemistry battery charging applications.

The BQ2573X charges the battery from a wide range of input sources including a 5-V USB adapter to a high-voltage USB PD source and traditional adapters.

During power up, the charger sets the converter to buck, boost, or buck-boost configuration based on the input source and battery conditions. During the charging cycle, the charger automatically transits among buck, boost, and buck-boost configuration without host control.

The BQ2573X monitors adapter current, battery current, and system power. The flexible programmed PROCHOT output goes directly to the CPU for throttle back, when needed.

For more details on register functions, see the [BQ25730 I<sup>2</sup>C 1-5 Cell Narrow VDC Buck-Boost Battery Charge Controller With System Power Monitor and Power Path Control](#) and [BQ25731 I<sup>2</sup>C 1-5 Cell Narrow VDC Buck-Boost Battery Charge Controller Data Sheets](#).

Table 1-1 lists the I/O descriptions.

**Table 1-1. I/O Description**

Jack	Description
J1-VIN	Input: positive terminal
J1-PGND	Input: negative terminal (ground terminal)
J2-CHRG_OK	CHRG_OK output

**Table 1-1. I/O Description (continued)**

Jack	Description
J2-OTG/VAP	External OTG/VAP disable pin; Logic LOW to disable OTG/VAP
J2-CELL_CONTROL	External battery removal control; Logic high to pull CELL pin down
J2-ILIM_HIZ	External converter disable; Logic LOW to enable HIZ mode
J3-SCL	SMBUS/I2C SCL
J3-GND	Ground
J3-SDA	SMBUS/I2C SDA
J4-GND	Ground
J4-CMPIN	External CMPIN pin input
J4-CMPOUT	CMPOUT pin output
J5-VBAT	Connected to battery pack output
J5-PGND	Ground
J6-VSYS	Connected to system output
J6-PGND	Ground
J7-SDA	SMBUS/I2C SDA
J7-SCL	SMBUS/I2C SCL
J7-GND	Ground

Table 1-2 displays the controls and key parameters settings.

**Table 1-2. Controls and Key Parameters Setting**

Jumper	Description	Factory Setting
JP2	Jumper on: Forward Mode Jumper off: Enable OTG	Installed
JP3	CELL setting 1S: JP3(1-2) measure CELL pin voltage 1.2 V 2S: JP3(3-4) measure CELL pin voltage 2.7 V 3S: JP3(5-6) measure CELL pin voltage 3.9 V 4S: JP3(7-8) measure CELL pin voltage 4.2 V 5S: JP3(9-10) measure CELL pin voltage 6.0 V	JP3(3-4) installed
JP4	Jumper on: Bat removal Jumper off: Cell setting by JP3	Not installed
JP6	HIZ Enable Jumper on: Enable HiZ mode. Jumper off: ILIM is set by external resistor divider	Not installed
JP8	Jumper on: Onboard LDO to drive the EVM 3V3 Jumper off: disconnect onboard LDO to drive the EVM 3V3	Installed

Table 1-3 lists the recommended operating conditions.

**Table 1-3. Recommended Operating Conditions**

Symbol	Description	MIN	TYP	MAX	Unit
Supply voltage, $V_{IN}$	Input voltage from ac adapter input	3.5	5/12/20	26	V
Battery voltage, $V_{BAT}$	Voltage applied at VBAT terminal	0		23	V
Supply current, $I_{AC}$	Maximum input current from ac adapter input	0		10	A
Output current, $I_{OUT}$	Output current	0		15	A
Operating junction temperature range, $T_J$		0		125	°C

## 2 Test Summary

### 2.1 Definitions

This procedure details how to configure the BMS051 evaluation board. For the test procedure, the following naming conventions are followed. Refer to the [BMS051 schematic](#) for details.

VXXX:	External voltage supply name (VADP, VBT, VSBT).
LOADW:	External load name (LOADR, LOADI).
V(TPyyy):	Voltage at internal test point TPyyy. For example, V(TP12) means the voltage at TP12.
V(Jxx):	Voltage at jack terminal Jxx.
V(TP(XXX)):	Voltage at test point "XXX". For example, V(ACDET) means the voltage at the test point which is marked as "ACDET".
V(XXX, YYY):	Voltage across point XXX and YYY.
I(JXX(YYY)):	Current going out from the YYY terminal of jack XX.
Jxx(BBB):	Terminal or pin BBB of jack xx.
Jxx ON :	Internal jumper Jxx terminals are shorted.
Jxx OFF:	Internal jumper Jxx terminals are open.
Jxx (-YY-) ON:	Internal jumper Jxx adjacent terminals marked as "YY" are shorted.
Measure: → A,B	Check specified parameters A, B. If measured values are not within specified limits, the unit under test has failed.
Observe → A,B	Observe if A, B occurs. If they do not occur, the unit under test has failed.

[Assembly drawings](#) have locations for jumpers, test points, and individual components.

### 2.2 Equipment

The following list of equipment is required for fully testing the EVM:

#### 1. Power Supplies

A power supply capable of supplying 26 V at 10 A is required. While this part can handle larger voltage and current, it is not necessary for this procedure.

#### 2. Load #1

A 0- to 23-V/0- to 15-A, system DC electronic load and setting as constant current load mode.

#### 3. Load #2

A Kepco load: BOP36-12M, DC 0 to  $\pm 36$  V, 0 to  $\pm 12$  A (or higher), or equivalent.

#### 4. Meters

Six Fluke 75 multimeters, (equivalent or better) or: Four equivalent voltage meters and two equivalent current meters.

#### 5. Computer

A computer with at least one USB port and a USB cable.

#### 6. EV2400 Communication Kit

#### 7. Software

Download and properly install BQstudio from <http://www.ti.com/tool/BQstudio>.

## 2.3 Equipment Setup

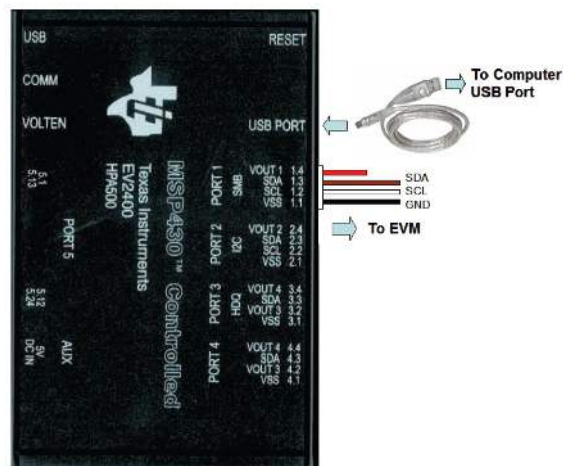
Use the following guidelines to set up the equipment:

1. Set power supply #1 for 10-V DC, 5-A current limit and then turn off the supply.
2. Connect the output of power supply #1 in series with a current meter to J1 (VIN and PGND).
3. Connect a voltage meter across J1 (VIN) and J1 (PGND).
4. Connect load #1 in series with a current meter to J6 (VSYS and PGND). Connect a voltage meter across J6 (VSYS and PGND). Set 1 A at the constant current mode. Turn off load #1.
5. Connect Load #2 in series with a current meter to J5 (VBAT and PGND). Connect a voltage meter across J5 (VBAT and PGND). Set 7 V at KEPCO load output. Turn off Load #2.

### Note

Add a 47- $\mu$ F capacitor on the BAT pin when testing without real battery.

6. Connect J3 to the EV2400. Connect J3 to the I<sup>2</sup>C PORT 2 on the EV2400. The connections are shown in [Figure 2-1](#).

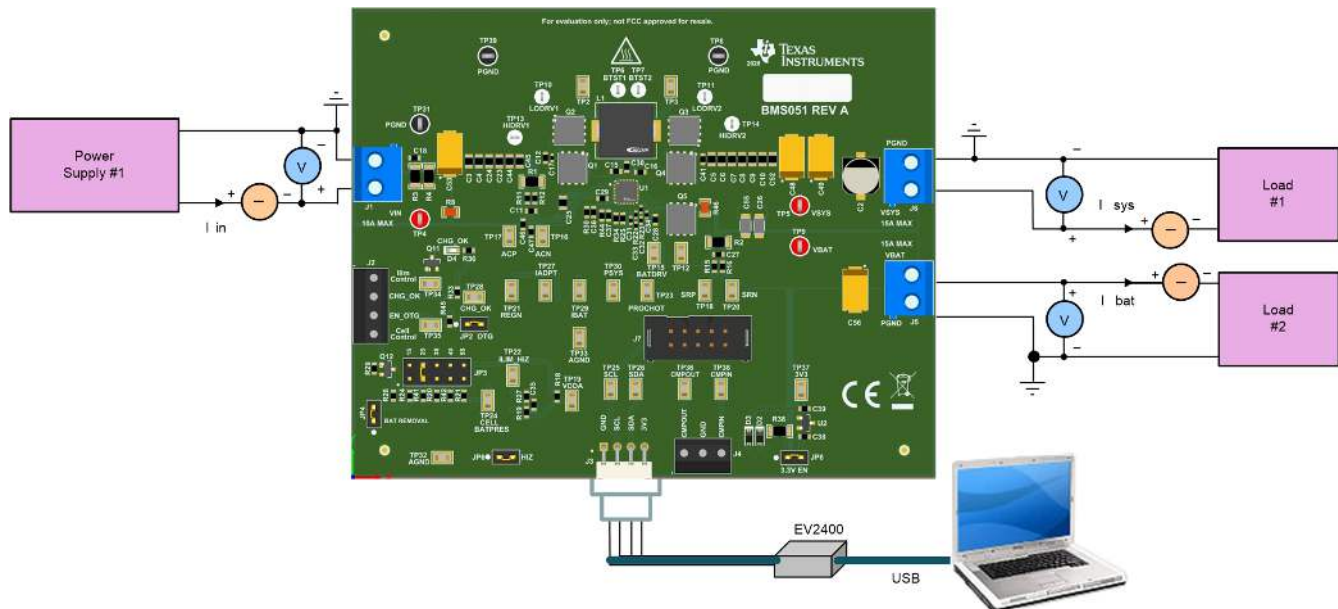


The picture shows the SMBus version EVM connection. For I<sup>2</sup>C version, move the connector to the I<sup>2</sup>C port.

**Figure 2-1. EV2400 Connections**

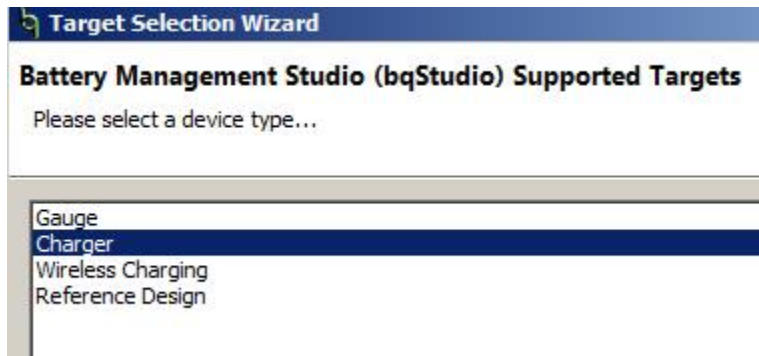
7. Install jumpers using the “factory settings” from [Table 1-2](#).

After completing these steps, the test setup for BMS051 is as shown in [Figure 2-2](#).



**Figure 2-2. Original Test Setup for BMS051 (BQ2573X EVM)**

8. Turn on the computer and power supply #1. Open the BQstudio software.
  - a. Select *Charger* and click the **Next** button.



- b. Select “Charger\_1\_00\_BQ2573x.bqz” on the *Select a Target Page*.
  - c. After selecting the target device, change “update mode” from “immediate” to “manual”, click “Read Register” and the following interface is presented.

Registers

Save Registers Load Registers Start Log Write Register Read Register Auto Read: OFF Update Mode Immediate Tgt Address D6(6B) Device ACK OK

Register Name	Address	Current Value	15	14	13	12	11	10	9	8	7	6	5	4	3	2	1	0
Charge Option 0	0x00	020E	0	0	0	0	0	0	1	0	0	0	0	0	1	1	1	0
Charge Current	0x02	0000	0	0	0	0	0	0	0	0	0	0	0	0	0	0	0	0
Max Charge Voltage	0x04	20D0	0	0	1	0	0	0	0	0	1	1	0	1	0	0	0	0
OTG Voltage	0x06	09C4	0	0	0	0	1	0	0	1	1	1	0	0	0	1	0	0
OTG Current	0x08	3C00	0	0	1	1	1	1	0	0	0	0	0	0	0	0	0	0
Input Voltage	0x0A	3A80	0	0	1	1	1	0	1	0	1	0	0	0	0	0	0	0
Min System Voltage	0x0C	2400	0	0	1	0	0	1	0	0	0	0	0	0	0	0	0	0
IIN_HOST	0x0E	2000	0	0	1	0	0	0	0	0	0	0	0	0	0	0	0	0
Charger Status	0x20	8000	1	0	0	0	0	0	0	0	0	0	0	0	0	0	0	0
Prochot Status	0x22	B800	1	0	1	1	1	0	0	0	0	0	0	0	0	0	0	0
IIN_DPM	0x24	2000	0	0	1	0	0	0	0	0	0	0	0	0	0	0	0	0
ADC VBUS and PSYS	0x26	CB00	1	1	0	0	1	0	1	1	0	0	0	0	0	0	0	0
ADC IBAT	0x28	0000	0	0	0	0	0	0	0	0	0	0	0	0	0	0	0	0
ADC IIN and CMPIN	0x2A	0000	0	0	0	0	0	0	0	0	0	0	0	0	0	0	0	0
ADC VSYS and VBAT	0x2C	0000	0	0	0	0	0	0	0	0	0	0	0	0	0	0	0	0
Manufacture ID	0x2E	D540	1	1	0	1	0	1	0	1	0	1	0	0	0	0	0	0
Device ID	0x2F	00D5	0	0	0	0	0	0	0	0	1	1	0	1	0	1	0	1
Charge Option 1	0x30	3F00	0	0	1	1	1	1	1	1	0	0	0	0	0	0	0	0
Charge Option 2	0x32	00B7	0	0	0	0	0	0	0	0	1	0	1	1	0	1	1	1
Charge Option 3	0x34	0434	0	0	0	0	0	1	0	0	0	0	1	1	0	1	0	0
Prochot Option 0	0x36	4A09	0	1	0	0	1	0	1	0	0	0	0	0	1	0	0	1
Prochot Option 1	0x38	41A0	0	1	0	0	0	0	0	1	1	0	1	0	0	0	0	0
ADC Option	0x3A	2000	0	0	1	0	0	0	0	0	0	0	0	0	0	0	0	0
Charge Option 4	0x3C	0048	0	0	0	0	0	0	0	0	0	1	0	0	1	0	0	0
Vmin Active Protection	0x3E	0004	0	0	0	0	0	0	0	0	0	0	0	0	0	1	0	0

**Charge Option 0**

EN\_LWPOWER

WDTMR\_ADJ

IIN\_DPM\_AUTO\_DISABLE

OTG\_ON\_CHRGOK

EN\_OOA

PWM\_FREQ

LOW\_PTM\_RIPPLE

EN\_CMP\_LATCH

SYS\_UVP\_ENZ

EN\_LEARN

IADPT Gain

IDCHG Gain

EN\_LDO

EN\_IIN\_DPM

CHRГ\_INHIBIT

Figure 2-3. BQ2573X Evaluation Software Main Window



## 2.4 Procedure

### 2.4.1 Charge Function

1. Make sure [Equipment Setup](#) steps are followed.
2. Set Tgt Address to D6(6B)
3. Write "020A" to charge option 0 register 0x00H.  
Measure → V(J1(V<sub>IN</sub>)) = 10 V ±0.5 V  
Measure → V(TP28(CHG\_OK)) = 3 V to 4.5 V  
Measure → V(TP21(REGN)) = 6 V ±1 V  
Measure → V(TP22(ILIM\_HIZ)) = 2.2 V
4. Write "0400" to charge current 0x02H.  
Turn on load #1.  
Measure → V(J6(VSYS)) = 8.4 V ±0.5 V
5. Turn on LOAD #2 (VBAT Load).  
Measure → V(J5(VBAT)) = 7 V ±0.5 V  
Measure → I(J5(VBAT)) = 2 A ±0.5 A

### 2.4.2 OTG Function

Use the following for OTG function settings:

1. Connect a 7-V power supply to the VBAT load. Remove the V<sub>IN</sub> power supply from J1 (Connection must be physically removed from board).
2. Write "09C4" to the OTG voltage register.
3. Write "1000" to the OTG current registers.
4. Remove JP2 (Enable OTG/VAP function).
5. Select *EN\_OTG* in *Charge Option 3*.  
Measure → V(J1(V<sub>IN</sub>)) = 5 V ±1 V

Registers

Save Registers | Load Registers | Start Log | Write Register | Read Register | Auto Read: OFF | Update Mode: Immediate | Tgt Address: D6(6B) | Device ACK OK

Register Name	Address	Current Value	15	14	13	12	11	10	9	8	7	6	5	4	3	2	1	0	
Charge Option 0	0x00	020A	0	0	0	0	0	0	1	0	0	0	0	0	1	0	1	0	
Charge Current	0x02	0000	0	0	0	0	0	0	0	0	0	0	0	0	0	0	0	0	
Max Charge Voltage	0x04	20D0	0	0	1	0	0	0	0	0	1	1	0	1	0	0	0	0	
OTG Voltage	0x06	09C4	0	0	0	0	1	0	0	1	1	1	0	0	0	1	0	0	
OTG Current	0x08	1000	0	0	0	1	0	0	0	0	0	0	0	0	0	0	0	0	
Input Voltage	0x0A	3A80	0	0	1	1	1	0	1	0	1	0	0	0	0	0	0	0	
Min System Voltage	0x0C	2400	0	0	1	0	0	1	0	0	0	0	0	0	0	0	0	0	
IIN_HOST	0x0E	2000	0	0	1	0	0	0	0	0	0	0	0	0	0	0	0	0	
Charger Status	0x20	8000	1	0	0	0	0	0	0	0	0	0	0	0	0	0	0	0	
Prochot Status	0x22	B800	1	0	1	1	1	0	0	0	0	0	0	0	0	0	0	0	
IIN_DPM	0x24	2000	0	0	1	0	0	0	0	0	0	0	0	0	0	0	0	0	
ADC VBUS and PSYS	0x26	CB00	1	1	0	0	1	0	1	1	0	0	0	0	0	0	0	0	
ADC IBAT	0x28	0000	0	0	0	0	0	0	0	0	0	0	0	0	0	0	0	0	
ADC IIN and CMPIN	0x2A	0000	0	0	0	0	0	0	0	0	0	0	0	0	0	0	0	0	
ADC VSYS and VBAT	0x2C	0000	0	0	0	0	0	0	0	0	0	0	0	0	0	0	0	0	
Manufacture ID	0x2E	D540	1	1	0	1	0	1	0	1	0	1	0	0	0	0	0	0	
Device ID	0x2F	00D5	0	0	0	0	0	0	0	0	1	1	0	1	0	1	0	1	
Charge Option 1	0x30	3F00	0	0	1	1	1	1	1	1	0	0	0	0	0	0	0	0	
Charge Option 2	0x32	00B7	0	0	0	0	0	0	0	0	1	0	1	1	0	1	1	1	
Charge Option 3	0x34	1434	0	0	0	1	0	1	0	0	0	0	1	1	0	1	0	0	
Prochot Option 0	0x36	4A09	0	1	0	0	1	0	1	0	0	0	0	0	1	0	0	1	
Prochot Option 1	0x38	41A0	0	1	0	0	0	0	0	1	1	0	1	0	0	0	0	0	
ADC Option	0x3A	2000	0	0	1	0	0	0	0	0	0	0	0	0	0	0	0	0	
Charge Option 4	0x3C	0048	0	0	0	0	0	0	0	0	0	0	1	0	0	1	0	0	
Vmin Active Protection	0x3E	0004	0	0	0	0	0	0	0	0	0	0	0	0	0	0	1	0	0

**Charge Option 3**

EN\_HIZ

RESET\_REG

RESET\_VINDPM

EN\_OTG

EN\_ICO\_MODE

EN\_PORT\_CTRL

VSYSMIN\_SOFTSTART

EN\_OTG\_BIGCAP

BATFET\_ENZ

EN\_VBUS\_VAP

OTG\_VAP\_MODE

IL\_AVG: 15A

CMP\_EN

BATFETOFF\_HIZ: BATFET on in HIZ

PSYS\_OTG\_IDCHG: PSYS = PBAT - PVBUS

Figure 2-4. EN\_OTG

### 3 Bill of Materials, Board Layout, and Schematics

This section contains the EVM BOM, board layout images, and schematics.

#### 3.1 Bill of Materials

Table 3-1 lists the BQ2573X EVM bill of materials.

**Table 3-1. BQ2573X EVM Bill of Materials**

Designator	QTY	Value	Description	Package Reference	Part Number	Manufacturer
!PCB1	1		Printed Circuit Board		BMS051	Any
C3, C4, C5, C6, C7, C8, C9, C10, C21, C23, C24, C40, C42, C43, C44, C45, C51, C52	18	10uF	CAP, CERM, 10 uF, 35 V, +/- 10%, X5R, 0805	805	GRM21BR6YA106KE43L	MuRata
C11, C12, C41	3	0.01uF	CAP, CERM, 0.01 uF, 50 V, +/- 5%, X7R, 0603	603	C0603C103J5RACTU	Kemet
C15, C16	2	0.047uF	CAP, CERM, 0.047 uF, 25 V, +/- 10%, X7R, 0603	603	GRM188R71E473KA01D	MuRata
C17	1	1000pF	CAP, CERM, 1000 pF, 50 V, +/- 5%, C0G/NP0, 0402	402	C1005NP01H102J050BA	TDK
C18, C28, C29	3	1uF	CAP, CERM, 1 uF, 35 V, +/- 10%, X7R, 0603	603	CGA3E1X7R1V105K080AC	TDK
C19, C20	2	150pF	CAP, CERM, 150 pF, 50 V, +/- 5%, C0G/NP0, 0603	603	C0603C151J5GACTU	Kemet
C22, C27, C38, C39	4	0.1uF	CAP, CERM, 0.1 uF, 50 V, +/- 10%, X7R, 0603	603	CGA3E2X7R1H104K080AA	TDK
C25	1	0.47uF	CAP, CERM, 0.47 uF, 50 V, +/- 10%, X7R, 0805	805	C2012X7R1H474K125AB	TDK
C26, C55	2	10uF	CAP, CERM, 10 uF, 25 V, +/- 10%, X7R, 1206	1206	GRM31CR71E106KA12L	MuRata
C30	1	2.2uF	CAP, CERM, 2.2 uF, 35 V, +/- 10%, X5R, 0603	603	GRM188R6YA225KA12D	MuRata
C31	1	33pF	CAP, CERM, 33 pF, 50 V, +/- 5%, C0G/NP0, 0402	402	GRM1555C1H330JA01D	MuRata
C32	1	680pF	CAP, CERM, 680 pF, 50 V, +/- 5%, C0G/NP0, 0402	402	GRM1555C1H681JA01D	MuRata
C33	1	4700pF	CAP, CERM, 4700 pF, 50 V, +/- 10%, X7R, 0402	402	GRM155R71H472KA01D	MuRata
C34	1	15pF	CAP, CERM, 15 pF, 50 V, +/- 5%, C0G/NP0, 0402	402	GRM1555C1H150JA01D	MuRata
C35, C36, C37	3	100pF	CAP, CERM, 100 pF, 50 V, +/- 5%, C0G/NP0, 0603	603	C0603C101J5GAC	Kemet
C46, C47	2	0.033uF	CAP, CERM, 0.033 uF, 50 V, +/- 10%, X7R, 0603	603	GRM188R71H333KA61D	MuRata
C48, C49, C53	3	33uF	CAP, TA, 33 uF, 35 V, +/- 20%, 0.065 ohm, SMD	7343-31	T521D336M035ATE065	Kemet
D2, D3	2	30V	Diode, Schottky, 30 V, 0.2 A, SOD-323	SOD-323	BAT54HT1G	ON Semiconductor
D4	1	Green	LED, Green, SMD	1.6x0.8x0.8mm	LTST-C190GKT	Lite-On
H1, H2, H3, H4	4		Bumpon, Hemisphere, 0.44 X 0.20, Clear	Transparent Bumpon	SJ-5303 (CLEAR)	3M
J1, J5, J6	3		Terminal Block, 5.08 mm, 2x1, Brass, TH	2x1 5.08 mm Terminal Block	ED120/2DS	On-Shore Technology
J2	1		Terminal Block, 3.5mm Pitch, 4x1, TH	14x8.2x6.5mm	ED555/4DS	On-Shore Technology
J3	1		Connector Header Through Hole, Right Angle 4 position 0.100" (2.54mm)	HDR4	22053041	Molex
J4	1		Terminal Block, 3.5mm Pitch, 3x1, TH	10.5x8.2x6.5mm	ED555/3DS	On-Shore Technology
J7	1		Header (shrouded), 100mil, 5x2, High-Temperature, Gold, TH	5x2 Shrouded header	N2510-6002-RB	3M
JP2, JP4, JP6, JP8	4		Header, 100mil, 2x1, Gold, TH	Header, 2x1, 100mil	5-146261-1	TE Connectivity
JP3	1		Header, 100mil, 5x2, Gold, TH	5x2 Header	TSW-105-07-G-D	Samtec

**Table 3-1. BQ2573X EVM Bill of Materials (continued)**

Designator	QTY	Value	Description	Package Reference	Part Number	Manufacturer
L1	1		4.7µH Shielded Wirewound Inductor 13A 9mOhm Max 10x10x4mm	SMT_IND_11MM2_10MM1	BMQADY1010404R7MA1	Chilisin Electronics
LBL1	1		Thermal Transfer Printable Labels, 0.650" W x 0.200" H - 10,000 per roll	PCB Label 0.650 x 0.200 inch	THT-14-423-10	Brady
Q1, Q2, Q3, Q4	4	30V	MOSFET, N-CH, 30 V, 27 A, DFN5x6	DFN5x6	AON6362	AOS
Q5	1	-30V	MOSFET, P-CH, -30 V, -85 A, DFN5x6	DFN5x6	AON6407	AOS
Q6, Q7	2	-30V	MOSFET, P-CH, -30 V, -8.5 A, AEC-Q101, 8-PowerVDFN	8-PowerVDFN	DMP3035SFG-7	Diodes Inc.
Q9	1	50 V	Transistor, NPN/PNP Pair, 50 V, 0.05 A, SC-74R	SC-74R	DCX124EK-7-F	Diodes Inc.
Q10, Q11, Q12	3	60V	MOSFET, N-CH, 60 V, 0.26 A, SOT-23	SOT-23	2N7002ET1G	ON Semiconductor
R1, R2	2	0.005	RES, 0.005, 1%, 1 W, AEC-Q200 Grade 0, 1206	1206	WSLP12065L000FEA	Vishay-Dale
R3, R4	2	3.9	RES, 3.9, 5%, 0.25 W, AEC-Q200 Grade 0, 1206	1206	CRCW12063R90JNEA	Vishay-Dale
R7, R24, R29	3	300k	RES, 300 k, 1%, 0.1 W, AEC-Q200 Grade 0, 0603	603	CRCW0603300KFKEA	Vishay-Dale
R8	1	0	RES, 0, 1%, 0.5 W, 0805	805	5106	Keystone
R9, R28	2	100k	RES, 100 k, 1%, 0.1 W, 0603	603	RC0603FR-07100KL	Yageo
R10, R38	2	10	RES, 10.0, 1%, 0.25 W, AEC-Q200 Grade 0, 1206	1206	ERJ-8ENF10R0V	Panasonic
R11, R12	2	4.99	RES, 4.99, 1%, 0.1 W, AEC-Q200 Grade 0, 0603	603	CRCW06034R99FKEA	Vishay-Dale
R13	1	1	RES, 1.0, 5%, 0.125 W, AEC-Q200 Grade 0, 0805	805	CRCW08051R00JNEA	Vishay-Dale
R14	1	20k	RES, 20 k, 5%, 0.1 W, AEC-Q200 Grade 0, 0603	603	CRCW060320K0JNEA	Vishay-Dale
R15, R16, R18	3	10	RES, 10, 5%, 0.1 W, AEC-Q200 Grade 0, 0603	603	CRCW060310R0JNEA	Vishay-Dale
R17, R25, R32, R33, R35, R39, R45	7	10.0k	RES, 10.0 k, 1%, 0.1 W, AEC-Q200 Grade 0, 0603	603	CRCW060310K0FKEA	Vishay-Dale
R19	1	383k	RES, 383 k, 1%, 0.1 W, AEC-Q200 Grade 0, 0603	603	CRCW0603383KFKEA	Vishay-Dale
R20	1	82k	RES, 82 k, 5%, 0.1 W, AEC-Q200 Grade 0, 0603	603	CRCW060382K0JNEA	Vishay-Dale
R21	1	1.00k	RES, 1.00 k, 1%, 0.1 W, AEC-Q200 Grade 0, 0603	603	CRCW06031K00FKEA	Vishay-Dale
R22	1	40.2k	RES, 40.2 k, 1%, 0.063 W, AEC-Q200 Grade 0, 0402	402	CRCW040240K2FKED	Vishay-Dale
R23	1	15.0k	RES, 15.0 k, 1%, 0.063 W, AEC-Q200 Grade 0, 0402	402	CRCW040215K0FKED	Vishay-Dale
R27	1	220k	RES, 220 k, 1%, 0.1 W, 0603	603	RC0603FR-07220KL	Yageo
R30	1	191k	RES, 191 k, 1%, 0.1 W, AEC-Q200 Grade 0, 0603	603	CRCW0603191KFKEA	Vishay-Dale
R34	1	30.1k	RES, 30.1 k, 1%, 0.1 W, AEC-Q200 Grade 0, 0603	603	CRCW060330K1FKEA	Vishay-Dale
R36	1	2.00k	RES, 2.00 k, 1%, 0.1 W, AEC-Q200 Grade 0, 0603	603	CRCW06032K00FKEA	Vishay-Dale
R40	1	2.0Meg	RES, 2.0 M, 5%, 0.1 W, AEC-Q200 Grade 0, 0603	603	CRCW06032M00JNEA	Vishay-Dale
R41	1	150k	RES, 150 k, 5%, 0.1 W, AEC-Q200 Grade 0, 0603	603	CRCW0603150KJNEA	Vishay-Dale
R42	1	33k	RES, 33 k, 5%, 0.1 W, AEC-Q200 Grade 0, 0603	603	CRCW060333K0JNEA	Vishay-Dale
SH-JP2, SH-JP3, SH-JP8	3	1x2	Shunt, 100mil, Gold plated, Black	Shunt	SNT-100-BK-G	Samtec

**Table 3-1. BQ2573X EVM Bill of Materials (continued)**

Designator	QTY	Value	Description	Package Reference	Part Number	Manufacturer
TP2, TP3, TP12, TP15, TP16, TP17, TP18, TP19, TP20, TP21, TP22, TP23, TP24, TP25, TP26, TP27, TP28, TP29, TP30, TP32, TP33, TP34, TP35, TP36, TP37, TP38	26	SMT	Test Point, Miniature, SMT	Testpoint_Keystone_Miniatu re	5015	Keystone
TP4, TP5, TP9	3		Test Point, Multipurpose, Red, TH	Red Multipurpose Testpoint	5010	Keystone
TP6, TP7, TP10, TP11, TP13, TP14	6	White	Test Point, Miniature, White, TH	White Miniature Testpoint	5002	Keystone
TP8, TP31, TP39	3		Test Point, Multipurpose, Black, TH	Black Multipurpose Testpoint	5011	Keystone
U1	1		I2C 1- to 5-Cell Narrow VDC Buck-Boost Battery Charge Controller	WQFN32	BQ25730RSN for BQ25730EVM; BQ25731RSN for BQ25731EVM	Texas Instruments
U2	1		100 mA, Quasi Low-Dropout Linear Voltage Regulator, 3-pin SOT-23, Pb-Free	DBZ0003A	LM3480IM3-3.3/NOPB	Texas Instruments
Z1	1	26V	Diode, TVS, Bi, 26 V, 42.1 Vc, 400 W, 9.5 A, SMA (non-polarized)	SMA (non-polarized)	SMAJ26CA	Littelfuse
C2	0	47uF	CAP, Aluminum Polymer, 47 uF, 25 V, +/- 20%, 0.03 ohm, F61 SMD	F61	25SVPF47M	Panasonic
C13, C14	0	330pF	CAP, CERM, 330 pF, 50 V, +/- 10%, X7R, 0603	603	GRM188R71H331KA01D	MuRata
C50, C54, C56	0	33uF	CAP, TA, 33 uF, 35 V, +/- 20%, 0.065 ohm, SMD	7343-31	T521D336M035ATE065	Kemet
C57	0	0.068uF	CAP, CERM, 0.068 uF, 50 V, +/- 10%, X7R, AEC-Q200 Grade 1, 0402	402	CGA2B3X7R1H683K050BB	TDK
C58, C59	0	0.018uF	CAP, CERM, 0.018 uF, 50 V, +/- 10%, X7R, 0603	603	GRM188R71H183KA01D	MuRata
D1	0	20V	Diode, Schottky, 20 V, 2 A, SMA	SMA	B220A-13-F	Diodes Inc.
FID1, FID2, FID3, FID4, FID5, FID6	0		Fiducial mark. There is nothing to buy or mount.	N/A	N/A	N/A
R5, R6	0	56	RES, 56, 5%, 0.1 W, AEC-Q200 Grade 0, 0603	603	CRCW060356R0JNEA	Vishay-Dale
R31	0	100	RES, 100, 1%, 0.1 W, AEC-Q200 Grade 0, 0603	603	CRCW0603100RFKEA	Vishay-Dale
R37	0	10.0k	RES, 10.0 k, 1%, 0.1 W, AEC-Q200 Grade 0, 0603	603	CRCW060310K0FKEA	Vishay-Dale
R43, R46	0	0	RES, 0, 1%, 0.5 W, 0805	805	5106	Keystone
R44	0	100k	RES, 100 k, 1%, 0.1 W, AEC-Q200 Grade 0, 0603	603	CRCW0603100KFKEA	Vishay-Dale
SH-JP4, SH-JP6	0	1x2	Shunt, 100mil, Gold plated, Black	Shunt	SNT-100-BK-G	Samtec

1. For BQ25730EVM, Install Q5 and do not install R46; For BQ25731EVM, Install R46 and do not install Q5.

### 3.2 Board Assembly Layout

Figure 3-1 and Figure 3-6 illustrate the board assembly layout images.

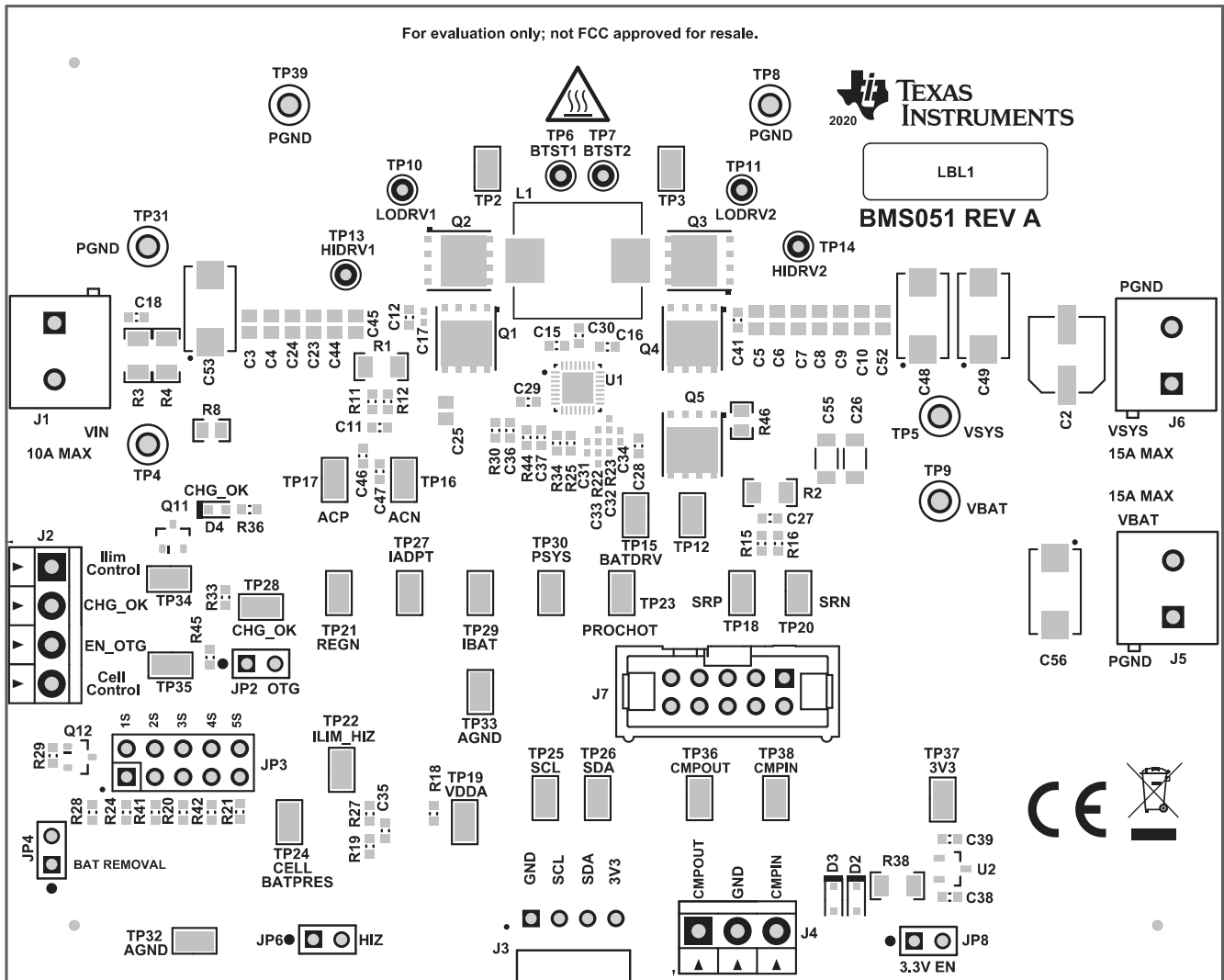
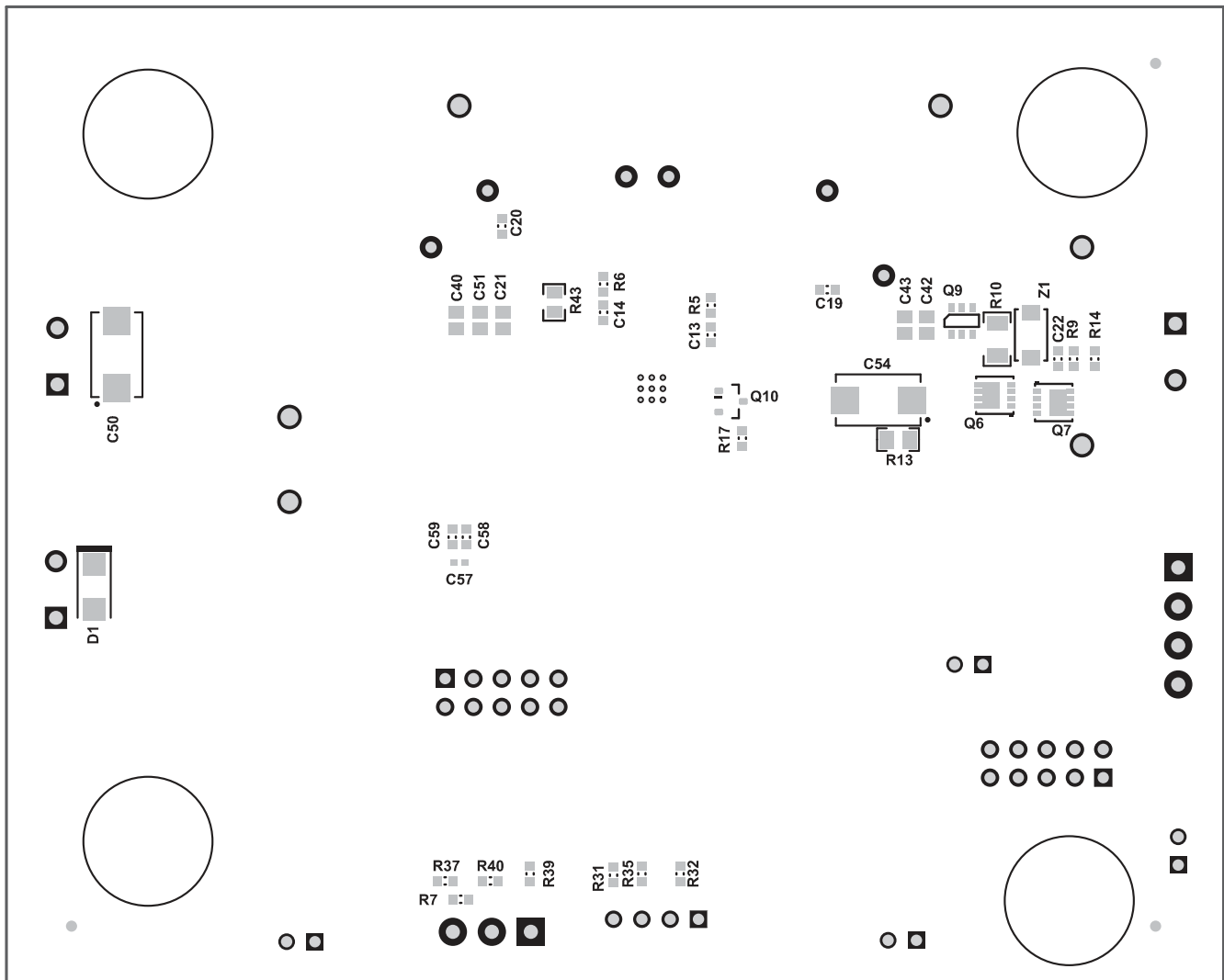
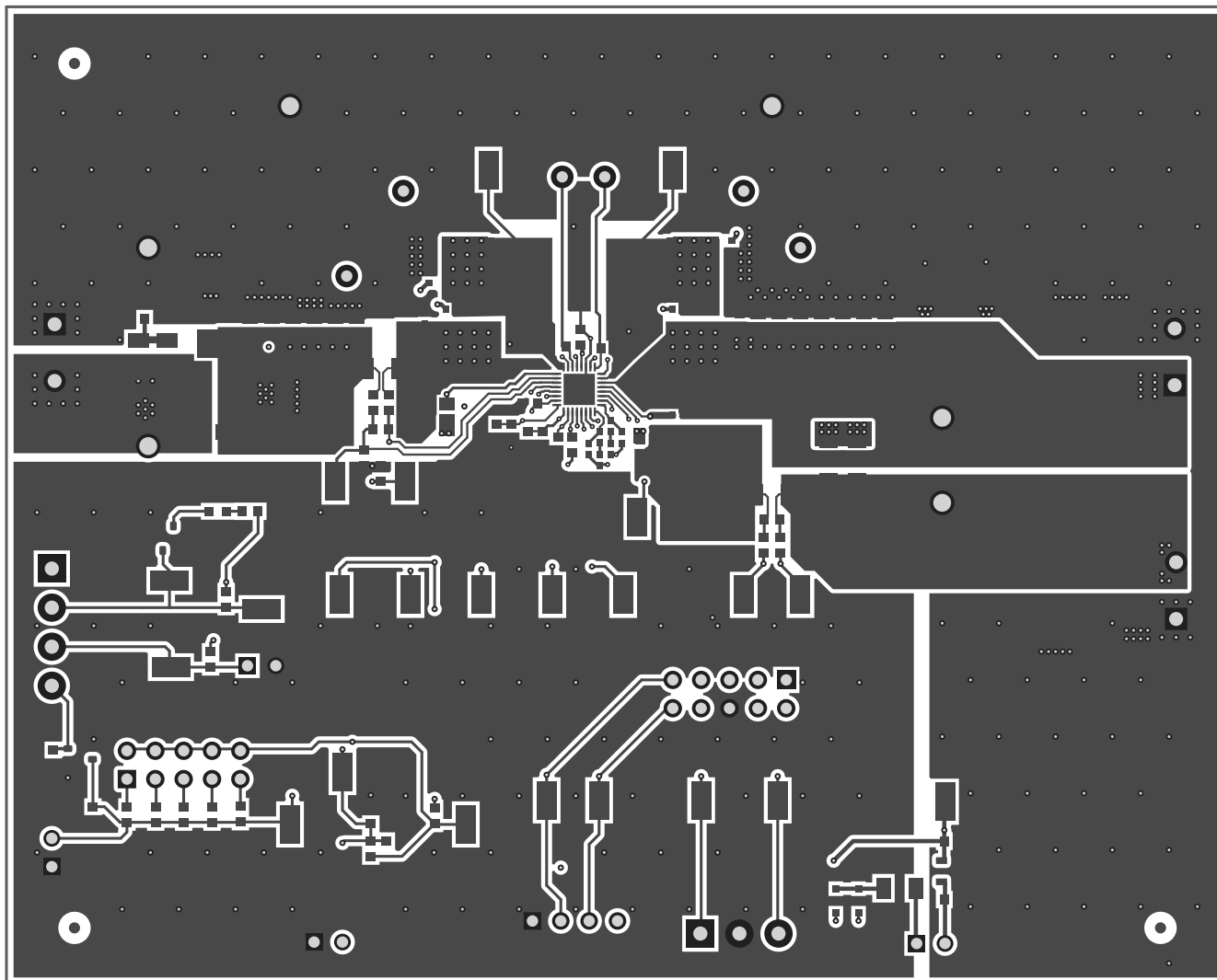


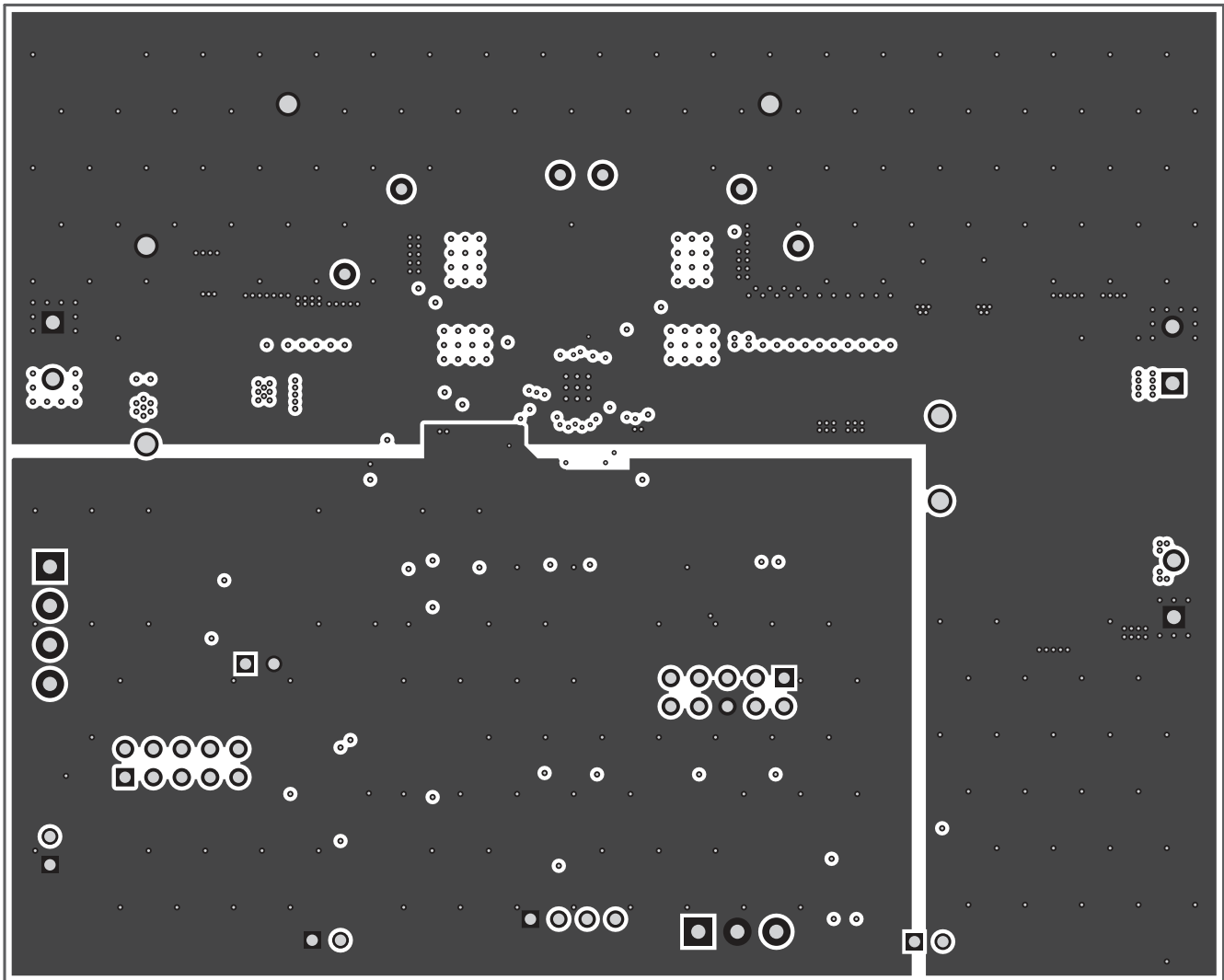
Figure 3-1. Top Assembly



**Figure 3-2. Bottom Assembly**

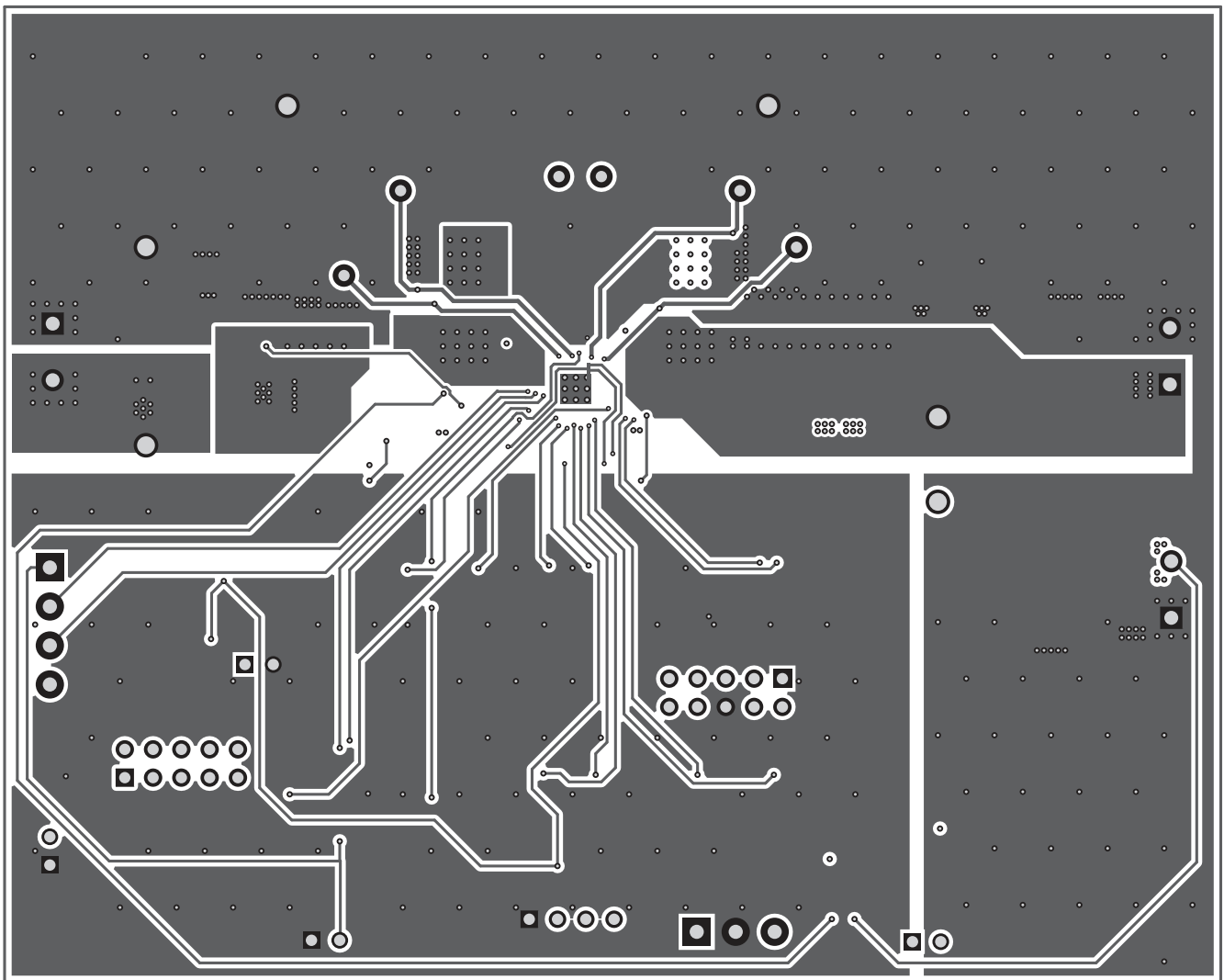


**Figure 3-3. PCB Layer 1**

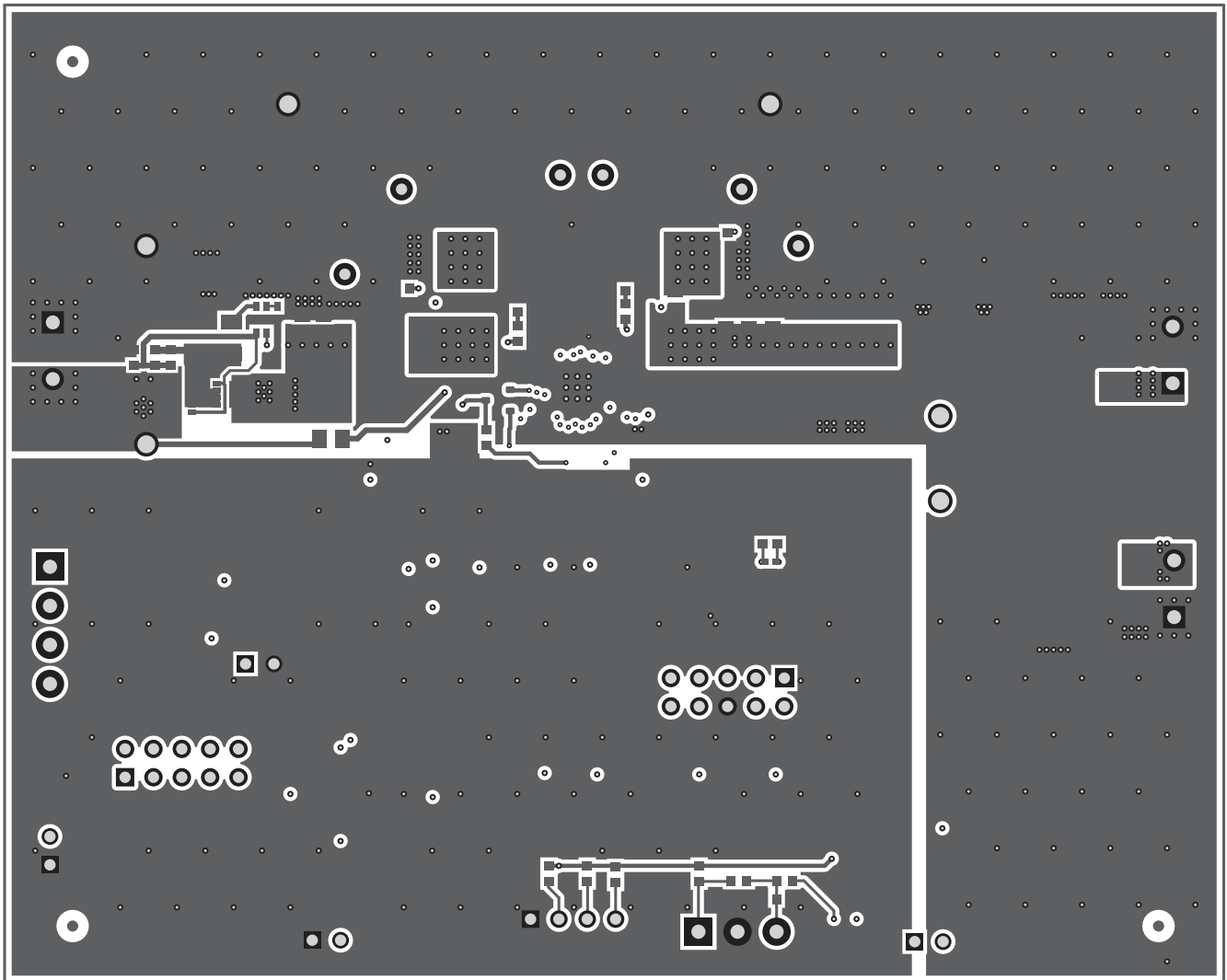


**Figure 3-4. PCB Layer 2**





**Figure 3-5. PCB Layer 3**



**Figure 3-6. PCB Layer 4**

### 3.3 Schematic

Figure 3-7 and Figure 3-8 show the EVM schematics.

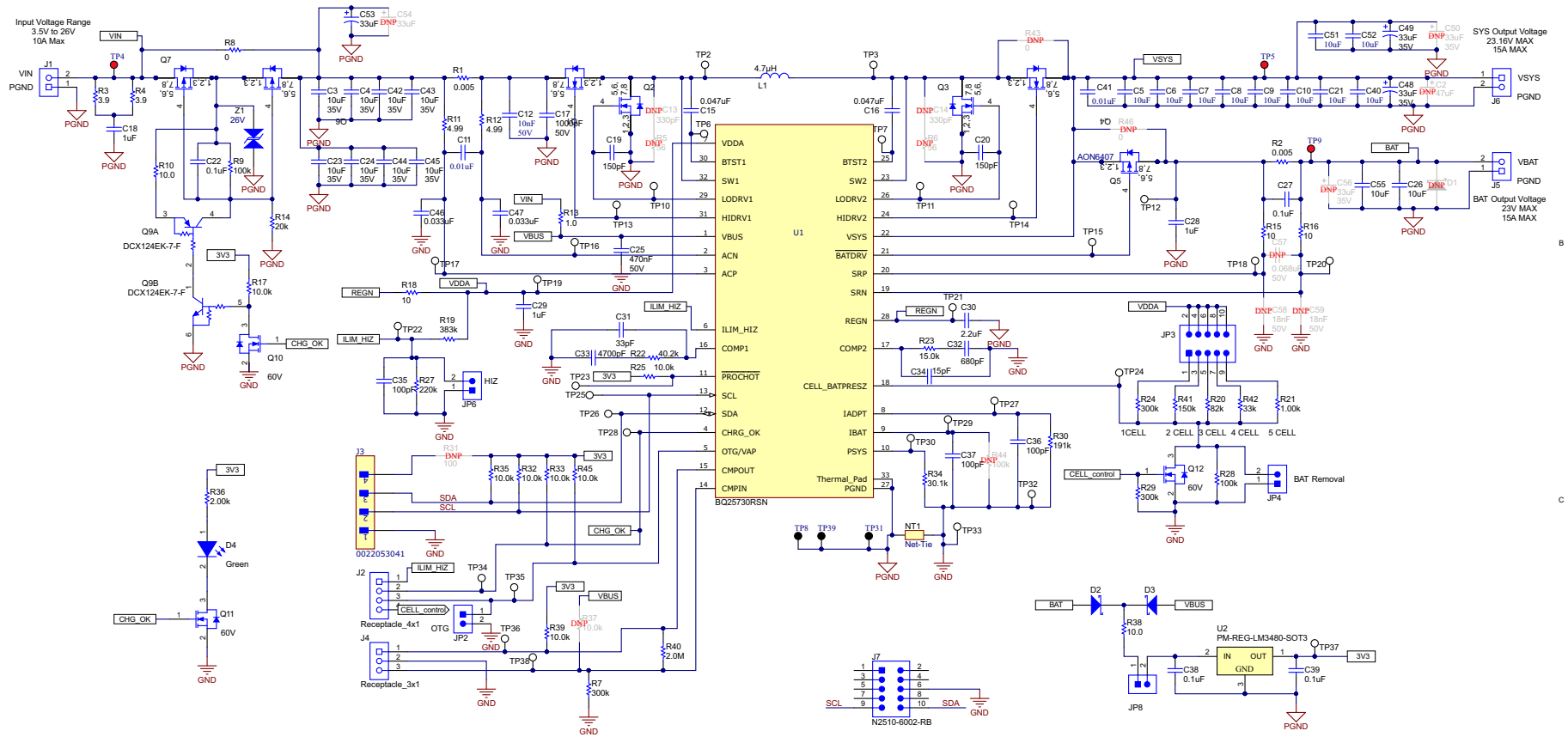


Figure 3-7. BQ25730 EVM Schematic

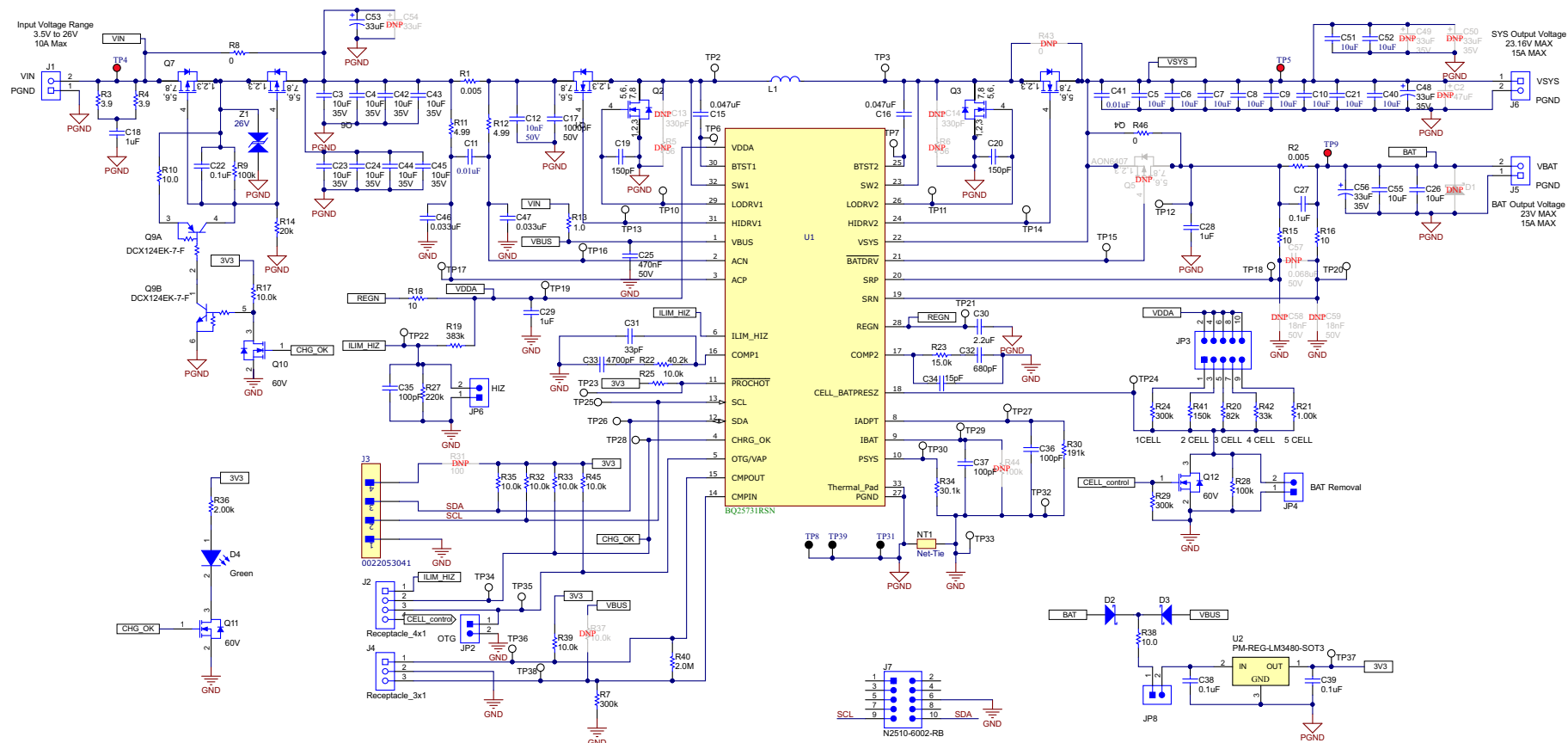


Figure 3-8. BQ25731 EVM Schematic

1. DNP means "Do Not Populate".

## Revision History

NOTE: Page numbers for previous revisions may differ from page numbers in the current version.

<b>Changes from Revision * (June 2020) to Revision A (January 2021)</b>	<b>Page</b>
• Updated the numbering format for tables, figures and cross-references throughout the document.....	1
• Updated all figures.....	1

## IMPORTANT NOTICE AND DISCLAIMER

TI PROVIDES TECHNICAL AND RELIABILITY DATA (INCLUDING DATA SHEETS), DESIGN RESOURCES (INCLUDING REFERENCE DESIGNS), APPLICATION OR OTHER DESIGN ADVICE, WEB TOOLS, SAFETY INFORMATION, AND OTHER RESOURCES "AS IS" AND WITH ALL FAULTS, AND DISCLAIMS ALL WARRANTIES, EXPRESS AND IMPLIED, INCLUDING WITHOUT LIMITATION ANY IMPLIED WARRANTIES OF MERCHANTABILITY, FITNESS FOR A PARTICULAR PURPOSE OR NON-INFRINGEMENT OF THIRD PARTY INTELLECTUAL PROPERTY RIGHTS.

These resources are intended for skilled developers designing with TI products. You are solely responsible for (1) selecting the appropriate TI products for your application, (2) designing, validating and testing your application, and (3) ensuring your application meets applicable standards, and any other safety, security, regulatory or other requirements.

These resources are subject to change without notice. TI grants you permission to use these resources only for development of an application that uses the TI products described in the resource. Other reproduction and display of these resources is prohibited. No license is granted to any other TI intellectual property right or to any third party intellectual property right. TI disclaims responsibility for, and you will fully indemnify TI and its representatives against, any claims, damages, costs, losses, and liabilities arising out of your use of these resources.

TI's products are provided subject to [TI's Terms of Sale](#) or other applicable terms available either on [ti.com](http://ti.com) or provided in conjunction with such TI products. TI's provision of these resources does not expand or otherwise alter TI's applicable warranties or warranty disclaimers for TI products.

TI objects to and rejects any additional or different terms you may have proposed.

Mailing Address: Texas Instruments, Post Office Box 655303, Dallas, Texas 75265  
Copyright © 2022, Texas Instruments Incorporated