

4 DIGIT DATE CODE ON THIS SURFACE, MUST BE SOLVENT RESISTANT

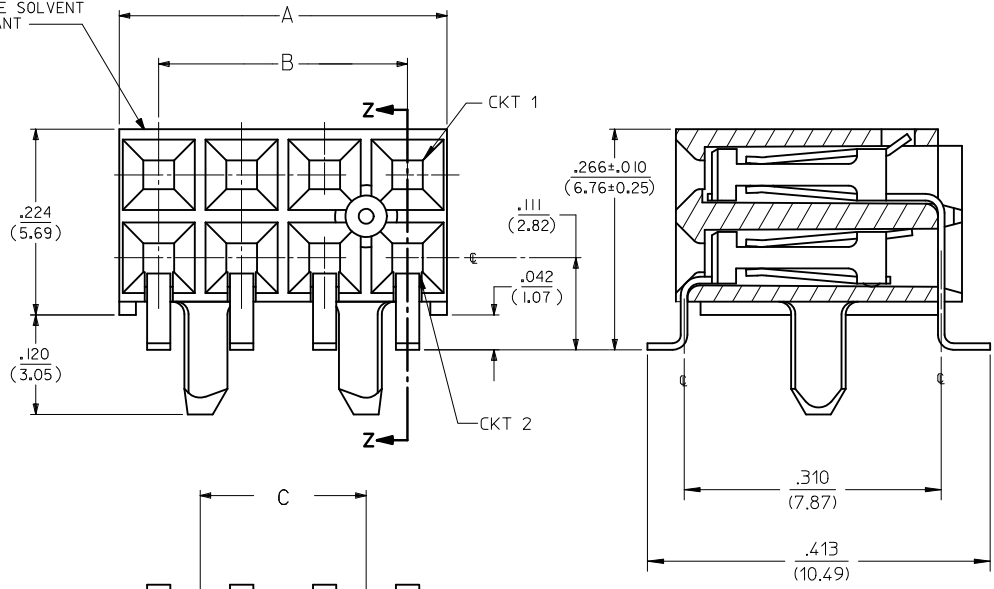

SECTION Z-Z

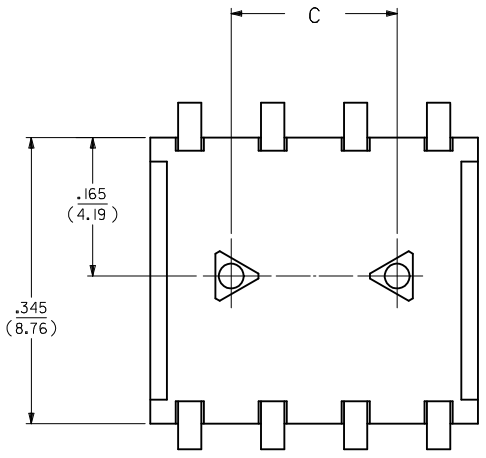

OPTION A ASSEMBLY
(ASSEMBLY WITH PEG AND WITHOUT LOWER ROW PINSTOP)

NOTES:

- 1.) MATERIALS:
HOUSING - LCP, 94V-0, BLACK
TERMINAL - PHOS. BRONZE ALLOY
- 2.) 8 CKT SHOWN FOR ILLUSTRATION PURPOSES. SEE CHART ON SHEET 7 FOR OTHER SIZES.
- 3.) SCRATCHES AND BURNISHING ALLOWED ON TERMINAL TAILS PROVIDING BASE METAL IS NOT EXPOSED, EXCEPT AT TRIMMED END.
- 4.) RECOMMENDED MATING PIN LENGTHS:
LOWER ROW - .200" MIN./ .285" MAX.
UPPER ROW - .200" MIN.
- 5.) REFER TO PS-71973-9999 FOR PERFORMANCE DATA.

PLATING:

- 15 GOLD 15 MICROINCH MINIMUM SELECTIVE GOLD IN THE CONTACT AREA; 75 MICROINCH MINIMUM SELECTIVE TIN IN THE PC TAIL AREA OVER 50 MICROINCH MINIMUM NICKEL OVERALL.
- 30 GOLD 30 MICROINCH MINIMUM SELECTIVE GOLD IN THE CONTACT AREA; 75 MICROINCH MINIMUM SELECTIVE TIN IN THE PC TAIL AREA OVER 50 MICROINCH MINIMUM NICKEL OVERALL.
- 50 GOLD 50 MICROINCH MINIMUM SELECTIVE GOLD IN THE CONTACT AREA; 75 MICROINCH MINIMUM SELECTIVE TIN IN THE PC TAIL AREA OVER 50 MICROINCH MINIMUM NICKEL OVERALL.

*THE PRIMARY SHIPPING CARTON WILL BE LABELED "COMPLIANT TO RoHS DIRECTIVE 2002/95/EC AND ELV ANNEX II OF DIRECTIVE 2000/53/EC". CARTONS WITHOUT THIS LABEL MAY CONTAIN PRODUCT WITH LEAD.

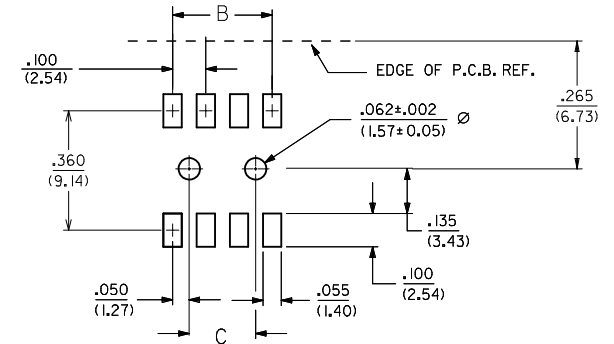

RECOMMENDED P.C.B. LAYOUT

REVISED AS PER GCN#10501265

EC NO: S2012-0693 DRW: NAI SEE CHKD: SKANG APPR: MLONG 2012/03/09 2012/03/09 2012/04/25	QUALITY SYMBOLS ▽=0 ◻=0	GENERAL TOLERANCES (UNLESS SPECIFIED)		DIMENSION STYLE		SCALE	DESIGN UNITS	THIRD ANGLE PROJECTION		
			mm	INCH	IN/MM		NTS	INCH		
		4 PLACES	± ---	± ---	DRAWN BY	DATE	TITLE			
		3 PLACES	± ---	± ---	CHECKED BY	DATE	SMT RECEPTACLE RIGHT ANGLE, DUAL ROW WITH AND WITHOUT PEG MOLEX INCORPORATED			
2 PLACES	± ---	± .01	APPROVED BY	DATE	DOCUMENT NO.					
1 PLACE	± 0.25	± ---	ANGULAR ± 1/2°		MATERIAL NO.		SD-71979-001		1 OF 2	
DRAFT WHERE APPLICABLE MUST REMAIN WITHIN DIMENSIONS			SEE TABLE		THIS DRAWING CONTAINS INFORMATION THAT IS PROPRIETARY TO MOLEX INCORPORATED AND SHOULD NOT BE USED WITHOUT WRITTEN PERMISSION					

NO. OF CKTS		OPTION A ASSEMBLY PLATINGS PER ES-88-(****) (SEE SHEET I FOR PLATING SPECIFICATIONS)					DIMENSION				NO. OF CKTS		OPTION A ASSEMBLY PLATINGS PER ES-88-(****) (SEE SHEET I FOR PLATING SPECIFICATIONS)					DIMENSION					
PER ROW	TOTAL				15 GOLD	30 GOLD	50 GOLD	A	B	C		PER ROW	TOTAL				15 GOLD	30 GOLD	50 GOLD	A	B	C	
4	8				71979-0204	71979-0304	71979-0404	.395 (10.03)	.300 (7.62)	.200 (5.08)		34	68						3.395 (86.23)	3.300 (83.82)	3.200 (81.28)		
5	10				71979-0205	71979-0305	71979-0405	.495 (12.57)	.400 (10.16)	.300 (7.62)		35	70						3.495 (88.77)	3.400 (86.36)	3.300 (83.82)		
6	12				71979-0206	71979-0306	71979-0406	.595 (15.1)	.500 (12.70)	.400 (10.16)		36	72						3.595 (91.31)	3.500 (88.90)	3.400 (86.36)		
7	14				71979-0207	71979-0307	71979-0407	.695 (17.65)	.600 (15.24)	.500 (12.70)													
8	16				71979-0208	71979-0308	71979-0408	.795 (20.19)	.700 (17.78)	.600 (15.24)													
9	18				71979-0209	71979-0309	71979-0409	.895 (22.73)	.800 (20.32)	.700 (17.78)													
10	20				71979-0210	71979-0310	71979-0410	.995 (25.27)	.900 (22.86)	.800 (20.32)													
11	22				71979-0211	71979-0311	71979-0411	1.095 (27.81)	1.000 (25.40)	.900 (22.86)													
12	24				71979-0212	71979-0312	71979-0412	1.195 (30.35)	1.100 (27.94)	1.000 (25.40)													
13	26				71979-0213	71979-0313	71979-0413	1.295 (32.89)	1.200 (30.48)	1.100 (27.94)													
14	28				71979-0214	71979-0314	71979-0414	1.395 (35.43)	1.300 (33.02)	1.200 (30.48)													
15	30				71979-0215	71979-0315	71979-0415	1.495 (37.97)	1.400 (35.56)	1.300 (33.02)													
16	32				71979-0216	71979-0316	71979-0416	1.595 (40.51)	1.500 (38.10)	1.400 (35.56)													
17	34				71979-0217	71979-0317	71979-0417	1.695 (43.05)	1.600 (40.64)	1.500 (38.10)													
18	36				71979-0218	71979-0318	71979-0418	1.795 (45.59)	1.700 (43.18)	1.600 (40.64)													
19	38				71979-0219	71979-0319	71979-0419	1.895 (48.13)	1.800 (45.72)	1.700 (43.18)													
20	40				71979-0220	71979-0320	71979-0420	1.995 (50.67)	1.900 (48.26)	1.800 (45.72)													
21	42				71979-0221	71979-0321	71979-0421	2.095 (53.21)	2.000 (50.80)	1.900 (48.26)													
22	44				71979-0222	71979-0322	71979-0422	2.195 (55.75)	2.100 (53.34)	2.000 (50.80)													
23	46				71979-0223	71979-0323	71979-0423	2.295 (58.29)	2.200 (55.88)	2.100 (53.34)													
24	48				71979-0224	71979-0324	71979-0424	2.395 (60.83)	2.300 (58.42)	2.200 (55.88)													
25	50				71979-0225	71979-0325	71979-0425	2.495 (63.37)	2.400 (60.96)	2.300 (58.42)													
26	52				71979-0226	71979-0326	71979-0426	2.595 (65.91)	2.500 (63.50)	2.400 (60.96)													
27	54				71979-0227	71979-0327	71979-0427	2.695 (68.45)	2.600 (66.04)	2.500 (63.50)													
28	56				71979-0228	71979-0328	71979-0428	2.795 (70.99)	2.700 (68.58)	2.600 (66.04)													
29	58				71979-0229	71979-0329	71979-0429	2.895 (73.53)	2.800 (71.12)	2.700 (68.58)													
30	60				71979-0230	71979-0330	71979-0430	2.995 (76.07)	2.900 (73.66)	2.800 (71.12)													
31	62				71979-0231	71979-0331	71979-0431	3.095 (78.61)	3.000 (76.20)	2.900 (73.66)													
32	64				71979-0232	71979-0332	71979-0432	3.195 (81.15)	3.100 (78.74)	3.000 (76.20)													
33	66				71979-0233	71979-0333	71979-0433	3.295 (83.69)	3.200 (81.28)	3.100 (78.74)													

NOTE: ALL CONNECTORS ARE PACKAGED IN TUBES PER PK-70873-0138

REVISED AS PER
GCN# 10501265
EC No: S2012-0693
2012/03/09
DRWINATSEE
CHKD:SKANG
2012/03/09
APPR:MLONG
2012/04/25

QUALITY SYMBOLS
▽=0
◁=0
DESCRIPTION
REV

GENERAL TOLERANCES (UNLESS SPECIFIED)
mm INCH
4 PLACES ± --- ± ---
3 PLACES ± --- ± ---
2 PLACES ± --- ± .01
1 PLACE ± 0.25 ± ---
ANGULAR ± 1/2°
DRAFT WHERE APPLICABLE
MUST REMAIN WITHIN DIMENSIONS

DIMENSION STYLE IN/MM
DRAWN BY DJB DATE 1995/03/15
CHECKED BY DJB DATE 1995/03/15
APPROVED BY MLONG DATE 2012/04/25
MATERIAL NO.
SEE TABLE

SCALE NTS
DESIGN UNITS INCH
THIRD ANGLE PROJECTION
TITLE SMT RECEPTACLE
RIGHT ANGLE, DUAL ROW
WITH AND WITHOUT PEG
MOLEX INCORPORATED
DOCUMENT NO. SD-71979-001
SHEET NO. 2 OF 2
THIS DRAWING CONTAINS INFORMATION THAT IS PROPRIETARY TO MOLEX INCORPORATED AND SHOULD NOT BE USED WITHOUT WRITTEN PERMISSION

4 DIGIT DATE CODE ON THIS SURFACE. MUST BE SOLVENT RESISTANT

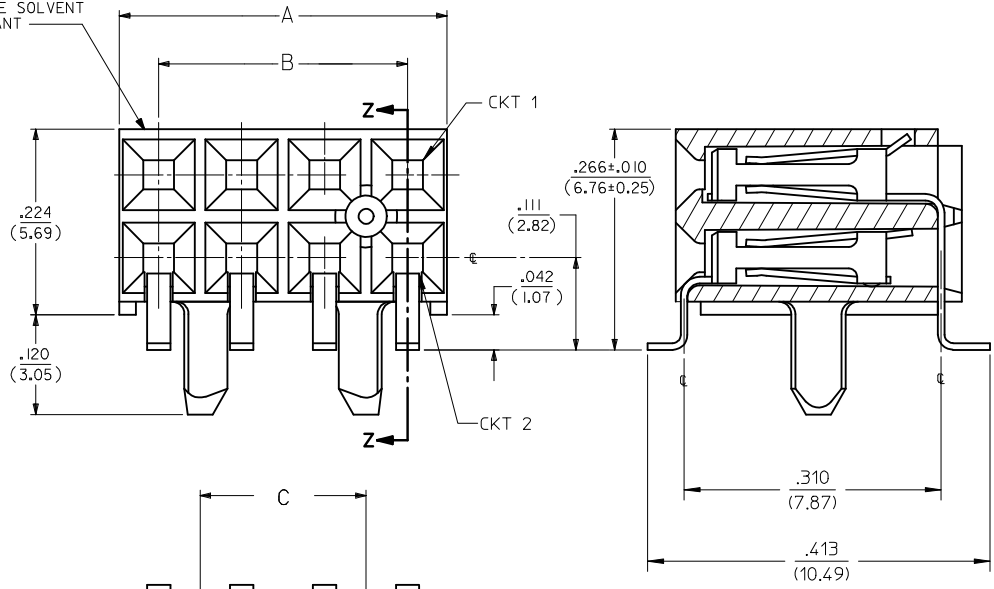

SECTION Z-Z

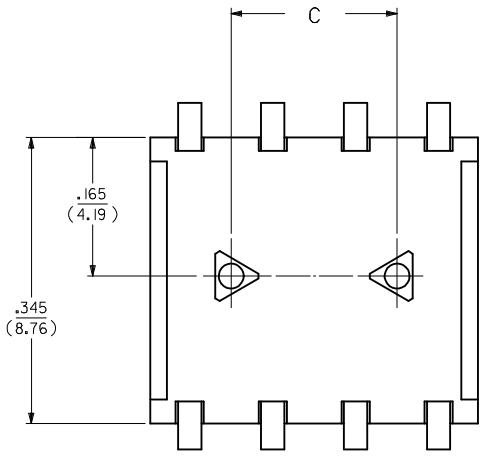

OPTION A ASSEMBLY
(ASSEMBLY WITH PEG AND WITHOUT LOWER ROW PINSTOP)

NOTES:

- 1.) MATERIALS:
HOUSING - LCP, 94V-0, BLACK
TERMINAL - PHOS. BRONZE ALLOY
- 2.) 8 CKT SHOWN FOR ILLUSTRATION PURPOSES. SEE CHART ON SHEET 7 FOR OTHER SIZES.
- 3.) SCRATCHES AND BURNISHING ALLOWED ON TERMINAL TAILS PROVIDING BASE METAL IS NOT EXPOSED, EXCEPT AT TRIMMED END.
- 4.) RECOMMENDED MATING PIN LENGTHS:
LOWER ROW - .200" MIN./ .285" MAX.
UPPER ROW - .200" MIN.
- 5.) REFER TO PS-71973-9999 FOR PERFORMANCE DATA.

PLATING:

- 15 GOLD 15 MICROINCH MINIMUM SELECTIVE GOLD IN THE CONTACT AREA; 75 MICROINCH MINIMUM SELECTIVE TIN IN THE PC TAIL AREA OVER 50 MICROINCH MINIMUM NICKEL OVERALL.
- 30 GOLD 30 MICROINCH MINIMUM SELECTIVE GOLD IN THE CONTACT AREA; 75 MICROINCH MINIMUM SELECTIVE TIN IN THE PC TAIL AREA OVER 50 MICROINCH MINIMUM NICKEL OVERALL.
- 50 GOLD 50 MICROINCH MINIMUM SELECTIVE GOLD IN THE CONTACT AREA; 75 MICROINCH MINIMUM SELECTIVE TIN IN THE PC TAIL AREA OVER 50 MICROINCH MINIMUM NICKEL OVERALL.

*THE PRIMARY SHIPPING CARTON WILL BE LABELED "COMPLIANT TO RoHS DIRECTIVE 2002/95/EC AND ELV ANNEX II OF DIRECTIVE 2000/53/EC". CARTONS WITHOUT THIS LABEL MAY CONTAIN PRODUCT WITH LEAD.

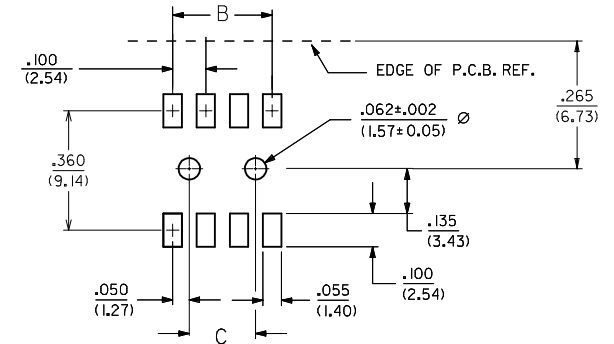

RECOMMENDED P.C.B. LAYOUT

REVISED EC NO: S2009-0814 DRWN:SKANG CHYKD:ATSEE APPR:MLONG	2009/09/01 2009/09/04 2009/09/05	DESCRIPTION H2	QUALITY SYMBOLS	GENERAL TOLERANCES (UNLESS SPECIFIED)	DIMENSION STYLE	SCALE	DESIGN UNITS	THIRD ANGLE PROJECTION
			▽=0 Ⓢ=0	mm INCH 4 PLACES ± --- ± --- 3 PLACES ± --- ± --- 2 PLACES ± --- ± .01 1 PLACE ± 0.25 ± --- ANGULAR ± 1/2°	IN/MM DRAWN BY: DJB DATE: 1995/03/15 CHECKED BY: DJB DATE: 1995/03/15 APPROVED BY: DJB DATE: 1995/03/15	NTS TITLE: SMT RECEPTACLE RIGHT ANGLE, DUAL ROW WITH AND WITHOUT PEG	MOLEX MOLEX INCORPORATED	
			DRAFT WHERE APPLICABLE MUST REMAIN WITHIN DIMENSIONS	SEE TABLE	MATERIAL NO. DOCUMENT NO. SDA-71979-****	SHEET NO. 1 OF 12		
			THIS DRAWING CONTAINS INFORMATION THAT IS PROPRIETARY TO MOLEX INCORPORATED AND SHOULD NOT BE USED WITHOUT WRITTEN PERMISSION					

4 DIGIT DATE CODE ON THIS SURFACE. MUST BE SOLVENT RESISTANT

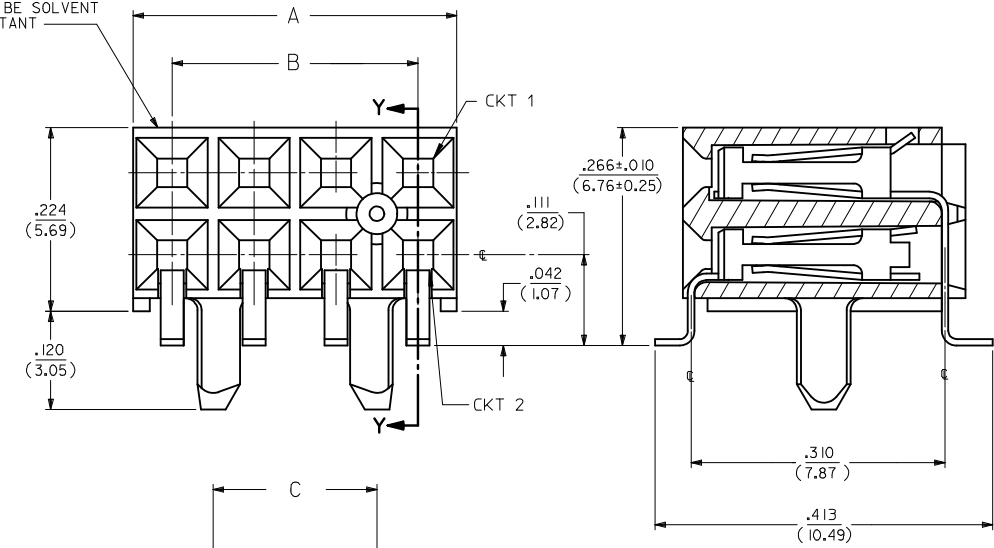

SECTION Y-Y

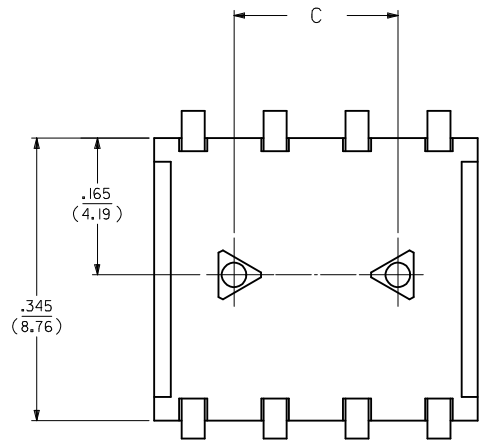

OPTION B ASSEMBLY

(ASSEMBLY WITH PEG AND LOWER ROW PINSTOP)

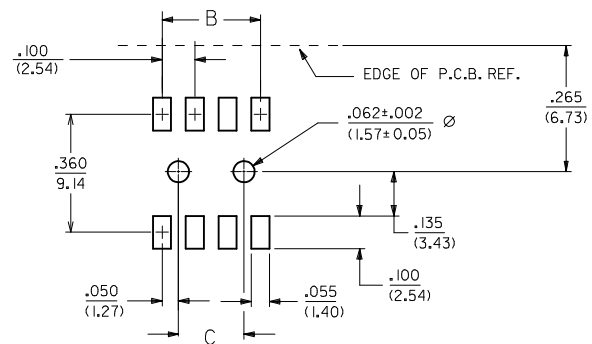

RECOMMENDED P.C.B. LAYOUT

NOTES:

- 1.) MATERIALS:
HOUSING - LCP, 94V-0, BLACK
TERMINAL - PHOS. BRONZE ALLOY
- 2.) 8 CKT SHOWN FOR ILLUSTRATION PURPOSES. SEE CHART ON SHEET 8 FOR OTHER SIZES.
- 3.) SCRATCHES AND BURNISHING ALLOWED ON TERMINAL TAILS PROVIDING BASE METAL IS NOT EXPOSED.
- 4.) RECOMMENDED MATING PIN LENGTHS:
LOWER ROW - .200' MIN./ .250'MAX.
UPPER ROW - .200' MIN.
- 5.) REFER TO PS-71973-9999 FOR PERFORMANCE DATA.

PLATING:

- 15 GOLD 15 MICROINCH MINIMUM SELECTIVE GOLD IN THE CONTACT AREA; 75 MICROINCH MINIMUM SELECTIVE TIN IN THE PC TAIL AREA OVER 50 MICROINCH MINIMUM NICKEL OVERALL.
 - 30 GOLD 30 MICROINCH MINIMUM SELECTIVE GOLD IN THE CONTACT AREA; 75 MICROINCH MINIMUM SELECTIVE TIN IN THE PC TAIL AREA OVER 50 MICROINCH MINIMUM NICKEL OVERALL.
 - 50 GOLD 50 MICROINCH MINIMUM SELECTIVE GOLD IN THE CONTACT AREA; 75 MICROINCH MINIMUM SELECTIVE TIN IN THE PC TAIL AREA OVER 50 MICROINCH MINIMUM NICKEL OVERALL.
- *THE PRIMARY SHIPPING CARTON WILL BE LABELED 'COMPLIANT TO RoHS DIRECTIVE 2002/95/EC AND ELY ANNEX II OF DIRECTIVE 2000/53/EC'. CARTONS WITHOUT THIS LABEL MAY CONTAIN PRODUCT WITH LEAD.

REVISED EC NO: S2009-0814 DRWN:SKANG CHKD:ATSEE APPR:MLONG	2009/09/01 2009/09/04 2009/09/05	QUALITY SYMBOLS ▽=0 C=0	GENERAL TOLERANCES (UNLESS SPECIFIED)		DIMENSION STYLE IN/MM		SCALE NTS	DESIGN UNITS INCH	THIRD ANGLE PROJECTION		
	4 PLACES ± --- ± --- 3 PLACES ± --- ± --- 2 PLACES ± --- ± .01 1 PLACE ± 0.25 ± ---		DRAWN BY DJB	DATE 1995/03/15	TITLE SMT RECEPTACLE RIGHT ANGLE, DUAL ROW WITH AND WITHOUT PEG						
	ANGULAR ± 1/2°		CHECKED BY DJB	DATE 1995/03/15	MOLEX INCORPORATED						
	DRAFT WHERE APPLICABLE MUST REMAIN WITHIN DIMENSIONS		APPROVED BY DJB	DATE 1995/03/15	MATERIAL NO. SEE TABLE	DOCUMENT NO. SDA-71979-****	SHEET NO. 2 OF 12				

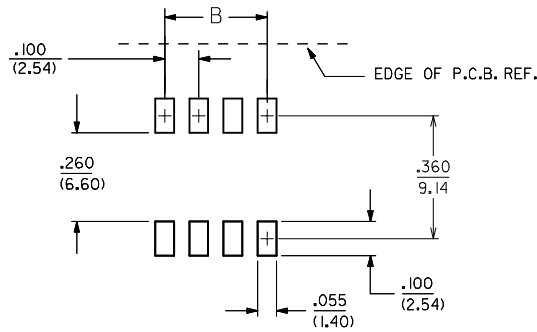
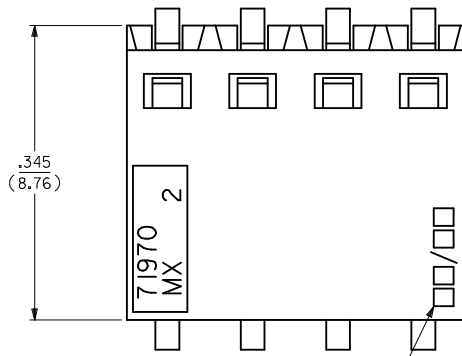

NOTES:

- 1.) MATERIALS:
HOUSING - LCP, 94V-0, BLACK.
TERMINAL - PHOS. BRONZE ALLOY
- 2.) 8 CKT SHOWN FOR ILLUSTRATION PURPOSES. SEE CHART ON SHEET 9 FOR OTHER SIZES.
- 3.) SCRATCHES AND BURNISHING ALLOWED ON TERMINAL TAILS PROVIDING BASE METAL IS NOT EXPOSED.
- 4.) MANUFACTURED DATE CODE WEEK/YEAR.
- 5.) RECOMMENDED MATING PIN LENGTHS:
LOWER ROW - .200" MIN./ .285" MAX.
UPPER ROW - .200" MIN.
- 6.) REFER TO PS-71973-9999 FOR PERFORMANCE DATA.

PLATING:

- 15 GOLD 15 MICROINCH MINIMUM SELECTIVE GOLD IN THE CONTACT AREA; 75 MICROINCH MINIMUM SELECTIVE TIN IN THE PC TAIL AREA OVER 50 MICROINCH MINIMUM NICKEL OVERALL.
 - 30 GOLD 30 MICROINCH MINIMUM SELECTIVE GOLD IN THE CONTACT AREA; 75 MICROINCH MINIMUM SELECTIVE TIN IN THE PC TAIL AREA OVER 50 MICROINCH MINIMUM NICKEL OVERALL.
 - 50 GOLD 50 MICROINCH MINIMUM SELECTIVE GOLD IN THE CONTACT AREA; 75 MICROINCH MINIMUM SELECTIVE TIN IN THE PC TAIL AREA OVER 50 MICROINCH MINIMUM NICKEL OVERALL.
- *THE PRIMARY SHIPPING CARTON WILL BE LABELED "COMPLIANT TO RoHS DIRECTIVE 2002/95/EC AND ELV ANNEX II OF DIRECTIVE 2000/53/EC". CARTONS WITHOUT THIS LABEL MAY CONTAIN PRODUCT WITH LEAD.

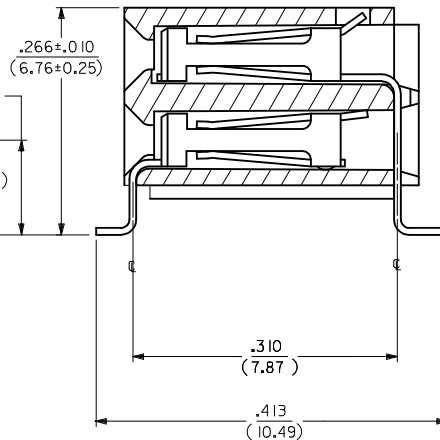
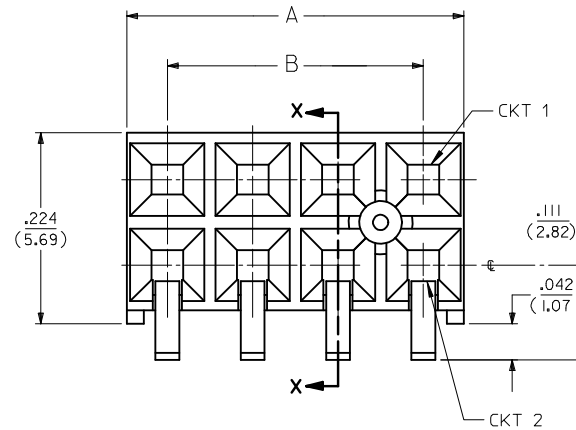

SECTION X-X

REVISED EC NO: S2009-0814 DRWN:SKANG CHKD:ATSEE APPR:MLONG 2009/09/01 2009/09/04 2009/09/05	QUALITY SYMBOLS	GENERAL TOLERANCES (UNLESS SPECIFIED)	DIMENSION STYLE	SCALE	DESIGN UNITS	THIRD ANGLE PROJECTION															
	$\nabla=0$ $\text{C}=0$	<table border="1"> <tr><th></th><th>mm</th><th>INCH</th></tr> <tr><td>4 PLACES</td><td>± ---</td><td>± ---</td></tr> <tr><td>3 PLACES</td><td>± ---</td><td>± ---</td></tr> <tr><td>2 PLACES</td><td>± ---</td><td>± .01</td></tr> <tr><td>1 PLACE</td><td>± 0.25</td><td>± ---</td></tr> </table>		mm	INCH	4 PLACES	± ---	± ---	3 PLACES	± ---	± ---	2 PLACES	± ---	± .01	1 PLACE	± 0.25	± ---	IN/MM	NTS	INCH	
		mm	INCH																		
	4 PLACES	± ---	± ---																		
3 PLACES	± ---	± ---																			
2 PLACES	± ---	± .01																			
1 PLACE	± 0.25	± ---																			
DESCRIPTION	ANGULAR ± 1/2°	DRAWN BY	DATE	TITLE																	
H2	DRAFT WHERE APPLICABLE MUST REMAIN WITHIN DIMENSIONS	DJB	1995/03/15	SMT RECEPTACLE RIGHT ANGLE, DUAL ROW WITH AND WITHOUT PEG																	
		CHECKED BY	DATE	MOLEX INCORPORATED																	
		APPROVED BY	DATE	SDA-71979-****																	
		MATERIAL NO.	DOCUMENT NO.	SHEET NO.																	
		SEE TABLE		3 OF 12																	
		SIZE A3	THIS DRAWING CONTAINS INFORMATION THAT IS PROPRIETARY TO MOLEX INCORPORATED AND SHOULD NOT BE USED WITHOUT WRITTEN PERMISSION																		

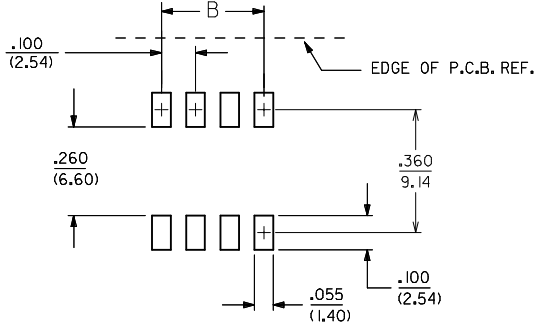
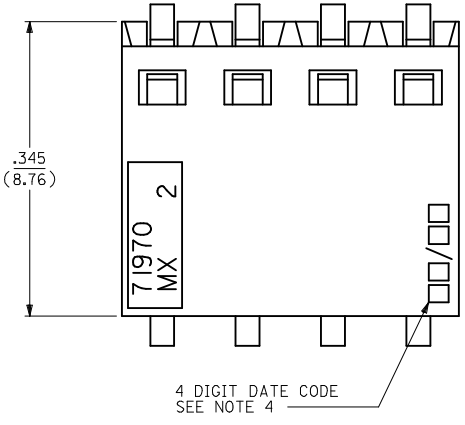

- NOTES:
- 1.) MATERIALS:
HOUSING - LCP, 94V-0, BLACK
TERMINAL - PHOS. BRONZE ALLOY
 - 2.) 8 CKT FOR ILLUSTRATION PURPOSES.
SEE CHART ON SHEET 10 FOR OTHER SIZES.
 - 3.) SCRATCHES AND BURNISHING ALLOWED ON
TERMINAL TAILS PROVIDING BASE METAL
IS NOT EXPOSED.
 - 4.) MANUFACTURED DATE CODE WEEK/YEAR.
 - 5.) RECOMMENDED MATING PIN LENGTHS:
LOWER ROW - .200" MIN./ .250" MAX.
UPPER ROW - .200" MIN.
 - 6.) REFER TO PS-71973-9999 FOR PERFORMANCE DATA.

- PLATING:
- 15 GOLD 15 MICROINCH MINIMUM SELECTIVE GOLD IN THE CONTACT AREA; 75 MICROINCH MINIMUM SELECTIVE TIN IN THE PC TAIL AREA OVER 50 MICROINCH MINIMUM NICKEL OVERALL.
 - 30 GOLD 30 MICROINCH MINIMUM SELECTIVE GOLD IN THE CONTACT AREA; 75 MICROINCH MINIMUM SELECTIVE TIN IN THE PC TAIL AREA OVER 50 MICROINCH MINIMUM NICKEL OVERALL.
 - 50 GOLD 50 MICROINCH MINIMUM SELECTIVE GOLD IN THE CONTACT AREA; 75 MICROINCH MINIMUM SELECTIVE TIN IN THE PC TAIL AREA OVER 50 MICROINCH MINIMUM NICKEL OVERALL.
- *THE PRIMARY SHIPPING CARTON WILL BE LABELED "COMPLIANT TO ROHS DIRECTIVE 2002/95/EC AND ELV ANNEX II OF DIRECTIVE 2000/53/EC". CARTONS WITHOUT THIS LABEL MAY CONTAIN PRODUCT WITH LEAD.

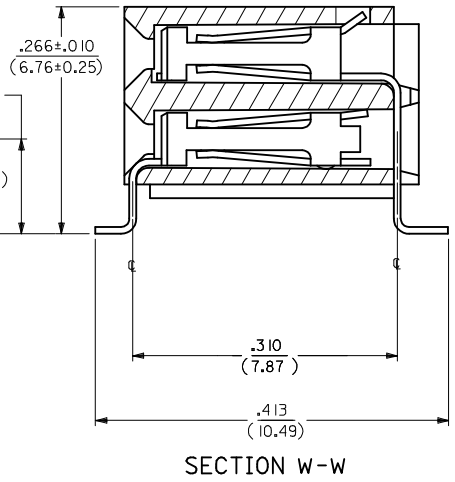
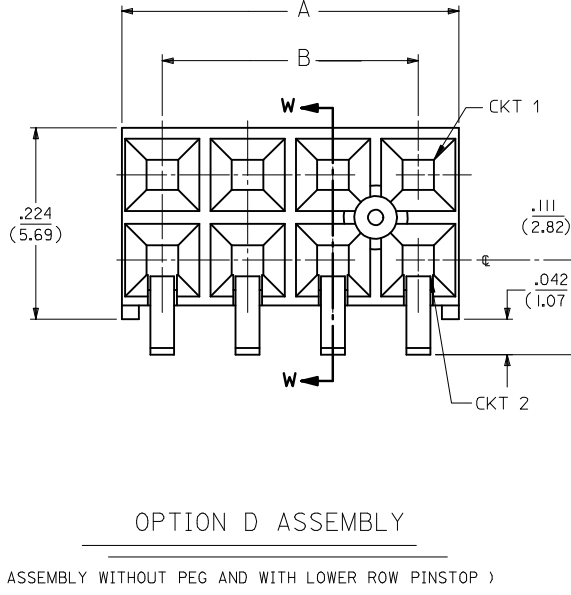

REVISED EC NO: S2009-0814 DRWN:SKANG CHKD:ATSEE APPR:MLONG 2009/09/01 2009/09/04 2009/09/05	QUALITY SYMBOLS	GENERAL TOLERANCES (UNLESS SPECIFIED)		DIMENSION STYLE IN/MM		SCALE NTS	DESIGN UNITS INCH	THIRD ANGLE PROJECTION
	▼=0 C=0	4 PLACES ± --- ± --- 3 PLACES ± --- ± --- 2 PLACES ± --- ± .01 1 PLACE ± 0.25 ± --- ANGULAR ± 1/2°	mm INCH ± --- ± --- ± --- ± .01 ± 0.25 ± ---	DRAWN BY DJB CHECKED BY DJB APPROVED BY DJB	DATE 1995/03/15 DATE 1995/03/15 DATE 1995/03/15	TITLE	SMT RECEPTACLE RIGHT ANGLE, DUAL ROW WITH AND WITHOUT PEG MOLEX INCORPORATED	SHEET NO. 4 OF 12
	DRAFT WHERE APPLICABLE MUST REMAIN WITHIN DIMENSIONS	SEE TABLE	MATERIAL NO.	DOCUMENT NO.				
		SIZE A3	THIS DRAWING CONTAINS INFORMATION THAT IS PROPRIETARY TO MOLEX INCORPORATED AND SHOULD NOT BE USED WITHOUT WRITTEN PERMISSION					

NOTES:

- 1.) MATERIALS:
HOUSING - VECTRA A-130, 94V-0, BLACK
TERMINAL - PHOS. BRONZE ALLOY 52L.
- 2.) 8 CKT SHOWN FOR ILLUSTRATION PURPOSES.
SEE CHART ON SHEET 11 FOR OTHER SIZES.
- 3.) SCRATCHES AND BURNISHING ALLOWED ON
TERMINAL TAILS PROVIDING BASE METAL
IS NOT EXPOSED.
- 4.) MANUFACTURED DATE CODE WEEK/YEAR.
- 5.) RECOMMENDED MATING PIN LENGTHS:
LOWER ROW - .200" MIN./ .285" MAX.
UPPER ROW - .200" MIN.
- 6.) REFER TO PS-71973-9999 FOR PERFORMANCE DATA.

PLATING:

- 15 GOLD 15 MICROINCH MINIMUM SELECTIVE GOLD IN THE CONTACT AREA; 75 MICROINCH MINIMUM SELECTIVE TIN IN THE PC TAIL AREA OVER 50 MICROINCH MINIMUM NICKEL OVERALL.
- 30 GOLD 30 MICROINCH MINIMUM SELECTIVE GOLD IN THE CONTACT AREA; 75 MICROINCH MINIMUM SELECTIVE TIN IN THE PC TAIL AREA OVER 50 MICROINCH MINIMUM NICKEL OVERALL.
- 50 GOLD 50 MICROINCH MINIMUM SELECTIVE GOLD IN THE CONTACT AREA; 75 MICROINCH MINIMUM SELECTIVE TIN IN THE PC TAIL AREA OVER 50 MICROINCH MINIMUM NICKEL OVERALL.

*THE PRIMARY SHIPPING CARTON WILL BE LABELED "COMPLIANT TO ROHS DIRECTIVE 2002/95/EC AND ELV ANNEX II OF DIRECTIVE 2000/53/EC". CARTONS WITHOUT THIS LABEL MAY CONTAIN PRODUCT WITH LEAD.

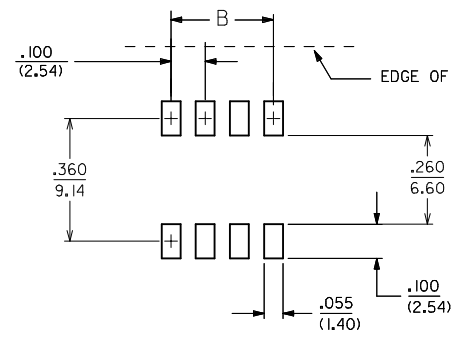
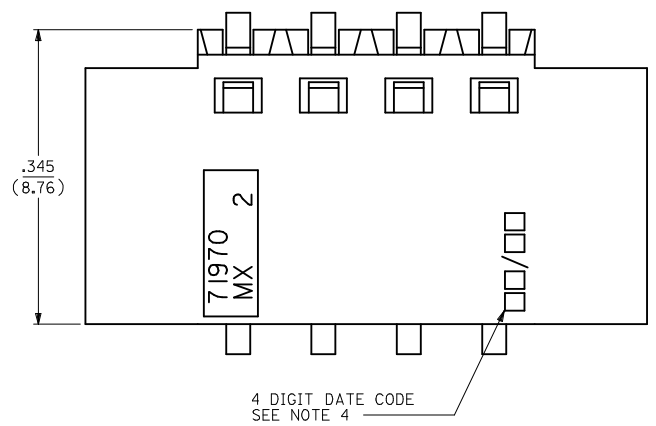

RECOMMENDED P.C.B. LAYOUT

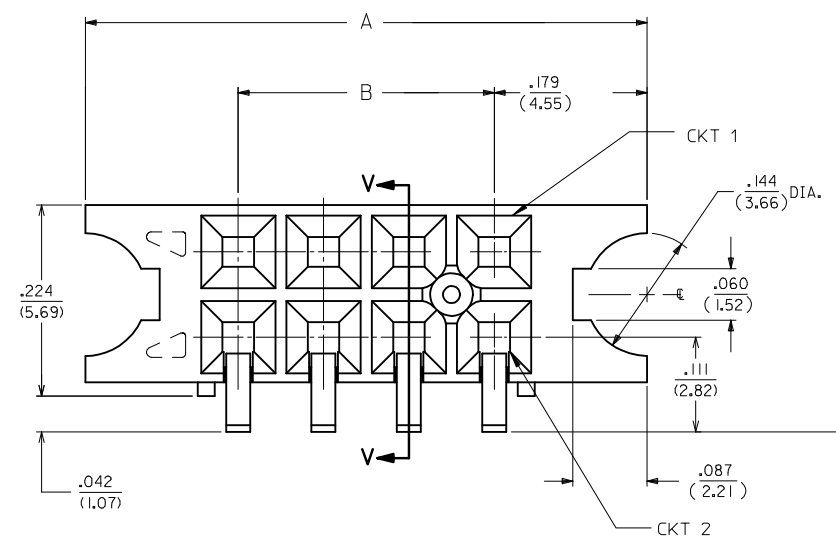

OPTION E ASSEMBLY

(ASSEMBLY WITHOUT PEG OR LOWER ROW PINSTOP, WITH FLANGE)

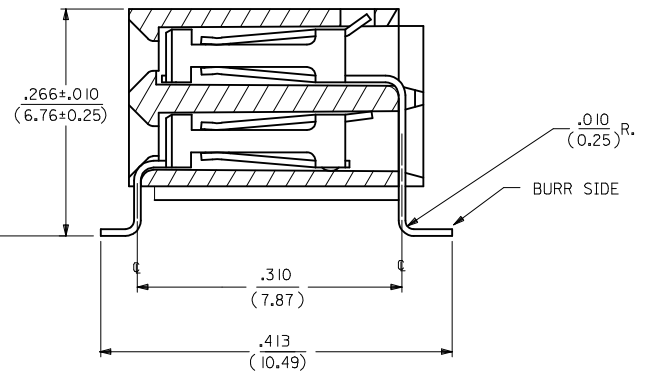

SECTION V - V

REVISED EC NO: S2009-0814 DRWN:SKANG CHKD:ATSEE APPR:MLONG 2009/09/01 2009/09/04 2009/09/05	QUALITY SYMBOLS	GENERAL TOLERANCES (UNLESS SPECIFIED)	DIMENSION STYLE	SCALE	DESIGN UNITS	THIRD ANGLE PROJECTION	
	▽=0 Ⓢ=0	mm INCH 4 PLACES ± --- ± --- 3 PLACES ± --- ± --- 2 PLACES ± --- ± .01 1 PLACE ± 0.25 ± --- ANGULAR ± 1/2°	IN/MM DRAWN BY: DJB DATE: 1995/03/15 CHECKED BY: DJB DATE: 1995/03/15 APPROVED BY: DJB DATE: 1995/03/15	NTS	INCH	□	
	DRAFT WHERE APPLICABLE MUST REMAIN WITHIN DIMENSIONS	MATERIAL NO. SEE TABLE	TITLE SMT RECEPTACLE RIGHT ANGLE, DUAL ROW WITH AND WITHOUT PEG	DOCUMENT NO. MOLEX INCORPORATED	SHEET NO. 5 OF 12		
	H2	SIZE A3	THIS DRAWING CONTAINS INFORMATION THAT IS PROPRIETARY TO MOLEX INCORPORATED AND SHOULD NOT BE USED WITHOUT WRITTEN PERMISSION				

NOTES:

- 1.) MATERIALS:
HOUSING - VECTRA A-130, 94V-0, BLACK
TERMINAL - PHOS. BRONZE ALLOY 521.
- 2.) 8 CKT SHOWN FOR ILLUSTRATION PURPOSES.
SEE CHART ON SHEET 12.
- 3.) SCRATCHES AND BURNISHING ALLOWED ON
TERMINAL TAILS PROVIDING BASE METAL
IS NOT EXPOSED.
- 4.) MANUFACTURED DATE CODE WEEK/YEAR.
- 5.) RECOMMENDED MATING PIN LENGTHS:
LOWER ROW - .200" MIN./ .285" MAX.
UPPER ROW - .200" MIN.
- 6.) REFER TO PS-71973-9999 FOR PERFORMANCE DATA.

PLATING:

- 15 GOLD 15 MICROINCH MINIMUM SELECTIVE GOLD IN THE CONTACT AREA; 75 MICROINCH MINIMUM SELECTIVE TIN IN THE PC TAIL AREA OVER 50 MICROINCH MINIMUM NICKEL OVERALL.
 - 30 GOLD 30 MICROINCH MINIMUM SELECTIVE GOLD IN THE CONTACT AREA; 75 MICROINCH MINIMUM SELECTIVE TIN IN THE PC TAIL AREA OVER 50 MICROINCH MINIMUM NICKEL OVERALL.
 - 50 GOLD 50 MICROINCH MINIMUM SELECTIVE GOLD IN THE CONTACT AREA; 75 MICROINCH MINIMUM SELECTIVE TIN IN THE PC TAIL AREA OVER 50 MICROINCH MINIMUM NICKEL OVERALL.
- *THE PRIMARY SHIPPING CARTON WILL BE LABELED "COMPLIANT TO ROHS DIRECTIVE 2002/95/EC AND ELV ANNEX II OF DIRECTIVE 2000/53/EC". CARTONS WITHOUT THIS LABEL MAY CONTAIN PRODUCT WITH LEAD.

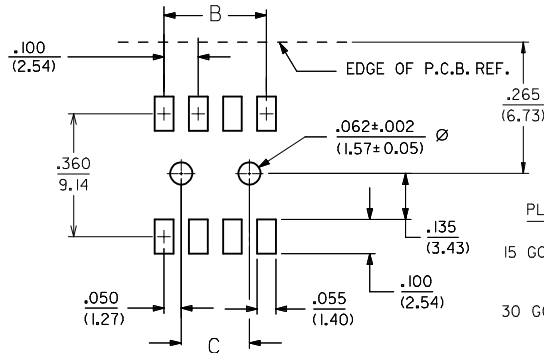
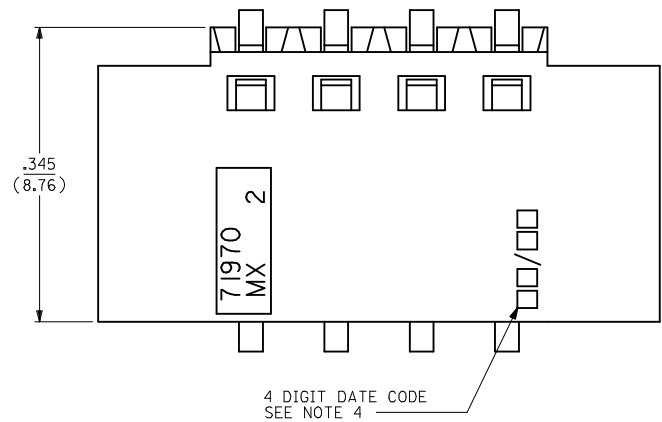

RECOMMENDED P.C.B. LAYOUT

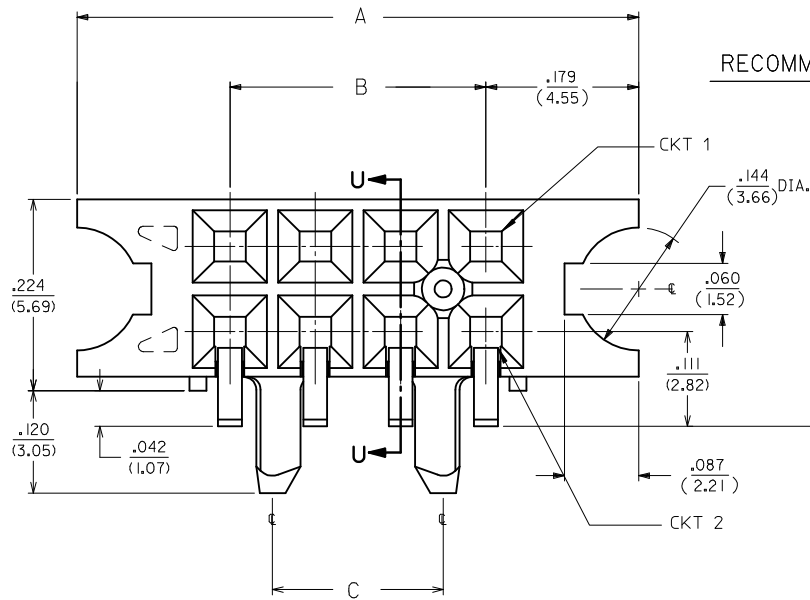

OPTION F ASSEMBLY

(ASSEMBLY WITHOUT LOWER ROW PINSTOP, WITH FLANGE AND PEG)

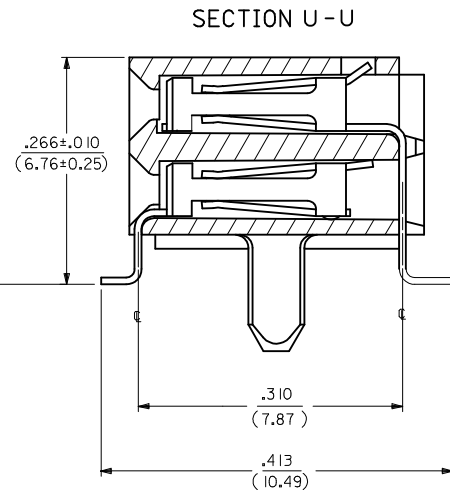

REVISED EC NO: S2009-0814 DRWN:SKANG CHKD:ATSEE APPR:MLONG 2009/09/01 2009/09/04 2009/09/05	QUALITY SYMBOLS ▽=0 ◻=0	GENERAL TOLERANCES (UNLESS SPECIFIED) mm INCH 4 PLACES ± --- ± --- 3 PLACES ± --- ± --- 2 PLACES ± --- ± .01 1 PLACE ± 0.25 ± --- ANGULAR ± 1/2°	DIMENSION STYLE IN/MM DRAWN BY DATE DJB 1995/03/15 CHECKED BY DATE DJB 1995/03/15 APPROVED BY DATE DJB 1995/03/15	SCALE NTS DESIGN UNITS INCH THIRD ANGLE PROJECTION	TITLE SMT RECEPTACLE RIGHT ANGLE, DUAL ROW WITH AND WITHOUT PEG MOLEX INCORPORATED
	H2	DRAFT WHERE APPLICABLE MUST REMAIN WITHIN DIMENSIONS	MATERIAL NO. SEE TABLE	DOCUMENT NO. SDA-71979-****	SHEET NO. 6 OF 12
	SIZE A3	THIS DRAWING CONTAINS INFORMATION THAT IS PROPRIETARY TO MOLEX INCORPORATED AND SHOULD NOT BE USED WITHOUT WRITTEN PERMISSION			

NO. OF CKTS		OPTION A ASSEMBLY PLATINGS PER ES-88-(***) (SEE SHEET I FOR PLATING SPECIFICATIONS)					DIMENSION				NO. OF CKTS		OPTION A ASSEMBLY PLATINGS PER ES-88-(***) (SEE SHEET I FOR PLATING SPECIFICATIONS)					DIMENSION					
PER ROW	TOTAL	15 GOLD			30 GOLD		50 GOLD		A	B	C	PER ROW	TOTAL	15 GOLD			30 GOLD		50 GOLD		A	B	C
4	8			71979-0204	71979-0304	71979-0404	.395 (10.03)	.300 (7.62)	.200 (5.08)			34	68			71979-0234	71979-0334	71979-0434	3.395 (86.23)	3.300 (83.82)	3.200 (81.28)		
5	10			71979-0205	71979-0305	71979-0405	.495 (12.57)	.400 (10.16)	.300 (7.62)			35	70			71979-0235	71979-0335	71979-0435	3.495 (88.77)	3.400 (86.36)	3.300 (83.82)		
6	12			71979-0206	71979-0306	71979-0406	.595 (15.11)	.500 (12.70)	.400 (10.16)			36	72			71979-0236	71979-0336	71979-0436	3.595 (91.31)	3.500 (88.90)	3.400 (86.36)		
7	14			71979-0207	71979-0307	71979-0407	.695 (17.65)	.600 (15.24)	.500 (12.70)														
8	16			71979-0208	71979-0308	71979-0408	.795 (20.19)	.700 (17.78)	.600 (15.24)														
9	18			71979-0209	71979-0309	71979-0409	.895 (22.73)	.800 (20.32)	.700 (17.78)														
10	20			71979-0210	71979-0310	71979-0410	.995 (25.27)	.900 (22.86)	.800 (20.32)														
11	22			71979-0211	71979-0311	71979-0411	1.095 (27.81)	1.000 (25.40)	.900 (22.86)														
12	24			71979-0212	71979-0312	71979-0412	1.195 (30.35)	1.100 (27.94)	1.000 (25.40)														
13	26			71979-0213	71979-0313	71979-0413	1.295 (32.89)	1.200 (30.48)	1.100 (27.94)														
14	28			71979-0214	71979-0314	71979-0414	1.395 (35.43)	1.300 (33.02)	1.200 (30.48)														
15	30			71979-0215	71979-0315	71979-0415	1.495 (37.97)	1.400 (35.56)	1.300 (33.02)														
16	32			71979-0216	71979-0316	71979-0416	1.595 (40.51)	1.500 (38.10)	1.400 (35.56)														
17	34			71979-0217	71979-0317	71979-0417	1.695 (43.05)	1.600 (40.64)	1.500 (38.10)														
18	36			71979-0218	71979-0318	71979-0418	1.795 (45.59)	1.700 (43.18)	1.600 (40.64)														
19	38			71979-0219	71979-0319	71979-0419	1.895 (48.13)	1.800 (45.72)	1.700 (43.18)														
20	40			71979-0220	71979-0320	71979-0420	1.995 (50.67)	1.900 (48.26)	1.800 (45.72)														
21	42			71979-0221	71979-0321	71979-0421	2.095 (53.21)	2.000 (50.80)	1.900 (48.26)														
22	44			71979-0222	71979-0322	71979-0422	2.195 (55.75)	2.100 (53.34)	2.000 (50.80)														
23	46			71979-0223	71979-0323	71979-0423	2.295 (58.29)	2.200 (55.88)	2.100 (53.34)														
24	48			71979-0224	71979-0324	71979-0424	2.395 (60.83)	2.300 (58.42)	2.200 (55.88)														
25	50			71979-0225	71979-0325	71979-0425	2.495 (63.37)	2.400 (60.96)	2.300 (58.42)														
26	52			71979-0226	71979-0326	71979-0426	2.595 (65.91)	2.500 (63.50)	2.400 (60.96)														
27	54			71979-0227	71979-0327	71979-0427	2.695 (68.45)	2.600 (66.04)	2.500 (63.50)														
28	56			71979-0228	71979-0328	71979-0428	2.795 (70.99)	2.700 (68.58)	2.600 (66.04)														
29	58			71979-0229	71979-0329	71979-0429	2.895 (73.53)	2.800 (71.12)	2.700 (68.58)														
30	60			71979-0230	71979-0330	71979-0430	2.995 (76.07)	2.900 (73.66)	2.800 (71.12)														
31	62			71979-0231	71979-0331	71979-0431	3.095 (78.61)	3.000 (76.20)	2.900 (73.66)														
32	64			71979-0232	71979-0332	71979-0432	3.195 (81.15)	3.100 (78.74)	3.000 (76.20)														
33	66			71979-0233	71979-0333	71979-0433	3.295 (83.69)	3.200 (81.28)	3.100 (78.74)														

NOTE: ALL CONNECTORS ARE PACKAGED IN TUBES PER PK-70873-0138

X INDICATES TOOLING IS NOT AVAILABLE.

REVISED
EC NO: S2009-0814
DRWN:SKANG
CHKD:ATSEE
APPR:MLONG
2009/09/01
2009/09/04
2009/09/05

QUALITY SYMBOLS
▽=0
◁=0
DESCRIPTION
REV

GENERAL TOLERANCES (UNLESS SPECIFIED)
mm INCH
4 PLACES ± --- ± ---
3 PLACES ± --- ± ---
2 PLACES ± --- ± .01
1 PLACE ± 0.25 ± ---
ANGULAR ± 1/2°
DRAFT WHERE APPLICABLE
MUST REMAIN WITHIN DIMENSIONS

DIMENSION STYLE IN/MM
DRAWN BY DATE
CHECKED BY DATE
APPROVED BY DATE
MATERIAL NO.
SEE TABLE

SCALE NTS
DESIGN UNITS INCH
THIRD ANGLE PROJECTION
TITLE
SMT RECEPTACLE
RIGHT ANGLE, DUAL ROW
WITH AND WITHOUT PEG
MOLEX INCORPORATED
DOCUMENT NO. SDA-71979-****
SHEET NO. 7 OF 12
THIS DRAWING CONTAINS INFORMATION THAT IS PROPRIETARY TO MOLEX INCORPORATED AND SHOULD NOT BE USED WITHOUT WRITTEN PERMISSION

10		9		8		7		6		5		4		3		2		1					
NO. OF CKTS		OPTION B ASSEMBLY PLATINGS PER ES-88-(****) (SEE SHEET I FOR PLATING SPECIFICATIONS)						DIMENSION				NO. OF CKTS		OPTION B ASSEMBLY PLATINGS PER ES-88-(****) (SEE SHEET I FOR PLATING SPECIFICATIONS)						DIMENSION			
PER ROW	TOTAL			15 GOLD	30 GOLD	50 GOLD	A	B	C	PER ROW	TOTAL			15 GOLD	30 GOLD	50 GOLD	A	B	C				
F	4	8		71979-1004	71979-1104	71979-1204	.395 (10.03)	.300 (7.62)	.200 (5.08)	34	68		71979-1034	71979-1134	71878-1234	3.395 (86.23)	3.300 (83.82)	3.200 (81.28)					
	5	10		71979-1005	71979-1105	71979-1205	.495 (12.57)	.400 (10.16)	.300 (7.62)	35	70		71979-1035	71979-1135	71878-1235	3.495 (88.77)	3.400 (86.36)	3.300 (83.82)					
	6	12		71979-1006	71979-1106	71979-1206	.595 (15.11)	.500 (12.70)	.400 (10.16)	36	72		71979-1036	71979-1136	71878-1236	3.595 (91.31)	3.500 (88.90)	3.400 (86.36)					
	7	14		71979-1007	71979-1107	71979-1207	.695 (17.65)	.600 (15.24)	.500 (12.70)														
	8	16		71979-1008	71979-1108	71979-1208	.795 (20.19)	.700 (17.78)	.600 (15.24)														
	9	18		71979-1009	71979-1109	71979-1209	.895 (22.73)	.800 (20.32)	.700 (17.78)														
	10	20		71979-1010	71979-1110	71979-1210	.995 (25.27)	.900 (22.86)	.800 (20.32)														
E	11	22		71979-1011	71979-1111	71979-1211	1.095 (27.81)	1.000 (25.40)	.900 (22.86)														
	12	24		71979-1012	71979-1112	71979-1212	1.195 (30.35)	1.100 (27.94)	1.000 (25.40)														
	13	26		71979-1013	71979-1113	71979-1213	1.295 (32.89)	1.200 (30.48)	1.100 (27.94)														
	14	28		71979-1014	71979-1114	71979-1214	1.395 (35.43)	1.300 (33.02)	1.200 (30.48)														
	15	30		71979-1015	71979-1115	71979-1215	1.495 (37.97)	1.400 (35.56)	1.300 (33.02)														
	16	32		71979-1016	71979-1116	71979-1216	1.595 (40.51)	1.500 (38.10)	1.400 (35.56)														
	17	34		71979-1017	71979-1117	71979-1217	1.695 (43.05)	1.600 (40.64)	1.500 (38.10)														
D	18	36		71979-1018	71979-1118	71979-1218	1.795 (45.59)	1.700 (43.18)	1.600 (40.64)														
	19	38		71979-1019	71979-1119	71979-1219	1.895 (48.13)	1.800 (45.72)	1.700 (43.18)														
	20	40		71979-1020	71979-1120	71979-1220	1.995 (50.67)	1.900 (48.26)	1.800 (45.72)														
	21	42		71979-1021	71979-1121	71979-1221	2.095 (53.21)	2.000 (50.80)	1.900 (48.26)														
	22	44		71979-1022	71979-1122	71979-1222	2.195 (55.75)	2.100 (53.34)	2.000 (50.80)														
	23	46		71979-1023	71979-1123	71979-1223	2.295 (58.29)	2.200 (55.88)	2.100 (53.34)														
	24	48		71979-1024	71979-1124	71979-1224	2.395 (60.83)	2.300 (58.42)	2.200 (55.88)														
	25	50		71979-1025	71979-1125	71979-1225	2.495 (63.37)	2.400 (60.96)	2.300 (58.42)														
C	26	52		71979-1026	71979-1126	71979-1226	2.595 (65.91)	2.500 (63.50)	2.400 (60.96)														
	27	54		71979-1027	71979-1127	71979-1227	2.695 (68.45)	2.600 (66.04)	2.500 (63.50)														
	28	56		71979-1028	71979-1128	71979-1228	2.795 (70.99)	2.700 (68.58)	2.600 (66.04)														
	29	58		71979-1029	71979-1129	71979-1229	2.895 (73.53)	2.800 (71.12)	2.700 (68.58)														
	30	60		71979-1030	71979-1130	71979-1230	2.995 (76.07)	2.900 (73.66)	2.800 (71.12)														
	31	62		71979-1031	71979-1131	71979-1231	3.095 (78.61)	3.000 (76.20)	2.900 (73.66)														
	32	64		71979-1032	71979-1132	71979-1232	3.195 (81.15)	3.100 (78.74)	3.000 (76.20)														
B	33	66		71979-1033	71979-1133	71979-1233	3.295 (83.69)	3.200 (81.28)	3.100 (78.74)														

NOTE: ALL CONNECTORS ARE PACKAGED IN TUBES PER PK-70873-0138

"X" INDICATES TOOLING IS NOT AVAILABLE.

REVISED EC NO: S2009-0814 DRWN:SKANG CHKD:ATSEE APPR:MLONG 2009/09/01 2009/09/04 2009/09/05	QUALITY SYMBOLS = 0 = 0	GENERAL TOLERANCES (UNLESS SPECIFIED) <table border="1"> <tr> <th></th> <th>mm</th> <th>INCH</th> </tr> <tr> <td>4 PLACES</td> <td>± ---</td> <td>± ---</td> </tr> <tr> <td>3 PLACES</td> <td>± ---</td> <td>± ---</td> </tr> <tr> <td>2 PLACES</td> <td>± ---</td> <td>± .01</td> </tr> <tr> <td>1 PLACE</td> <td>± 0.25</td> <td>± ---</td> </tr> </table>		mm	INCH	4 PLACES	± ---	± ---	3 PLACES	± ---	± ---	2 PLACES	± ---	± .01	1 PLACE	± 0.25	± ---	DIMENSION STYLE IN/MM	SCALE NTS	DESIGN UNITS INCH	THIRD ANGLE PROJECTION
		mm	INCH																		
	4 PLACES	± ---	± ---																		
	3 PLACES	± ---	± ---																		
2 PLACES	± ---	± .01																			
1 PLACE	± 0.25	± ---																			
DRAWN BY DJB	DATE 1995/03/15	TITLE SMT RECEPTACLE RIGHT ANGLE, DUAL ROW WITH AND WITHOUT PEG																			
CHECKED BY DJB	DATE 1995/03/15	APPROVED BY DJB																			
MATERIAL NO. SEE TABLE	DATE 1995/03/15	DOCUMENT NO. SDA-71979-****																			
DRAFT WHERE APPLICABLE MUST REMAIN WITHIN DIMENSIONS	SIZE A3	SHEET NO. 8 OF 12																			

10		9		8		7		6		5		4		3		2		1					
NO. OF CKTS		PACKAGING: TUBES PER PK-70873-0138		OPTION C ASSEMBLY PLATINGS PER ES-88-(****) (SEE SHEET 1 FOR PLATING SPECIFICATIONS)						DIMENSION		NO. OF CKTS		PACKAGING: TUBES PER PK-70873-0138		OPTION C ASSEMBLY PLATINGS PER ES-88-(****) (SEE SHEET 1 FOR PLATING SPECIFICATIONS)						DIMENSION	
PER ROW	TOTAL	TAPE AND REEL PER PK-70873-0918		15 GOLD		30 GOLD		50 GOLD		A	B	PER ROW	TOTAL			15 GOLD		30 GOLD		50 GOLD		A	B
4	8		PK-70873-0138		71979-1804		71979-1904		71979-2004	.395	.300		40		PK-70873-0138		71979-1820		71979-1920		71979-2020	1.995 (50.67)	1.900 (48.26)
			PK-70873-0918	X	71979-3804	X	71979-3904	X	71979-4004	(10.03)	(7.62)						71979-1821		71979-1921		71979-2021	2.095 (53.21)	2.000 (50.80)
5	10		PK-70873-0138		71979-1805		71979-1905		71979-2005	.495	.400		42		PK-70873-0138		71979-1822		71979-1922		71979-2022	2.195 (55.75)	2.100 (53.34)
			PK-70873-0918	X	71979-3805	X	71979-3905	X	71979-4005	(12.57)	(10.16)						71979-1823		71979-1923		71979-2023	2.295 (58.29)	2.200 (55.88)
6	12		PK-70873-0138		71979-1806		71979-1906		71979-2006	.595	.500		44		PK-70873-0138		71979-1824		71979-1924		71979-2024	2.395 (60.83)	2.300 (58.42)
			PK-70873-0918	X	71979-3806	X	71979-3906	X	71979-4006	(15.11)	(12.70)						71979-1825		71979-1925		71979-2025	2.495 (63.37)	2.400 (60.96)
7	14		PK-70873-0138		71979-1807		71979-1907		71979-2007	.695	.600		46		PK-70873-0138		71979-1826		71979-1926		71979-2026	2.595 (65.91)	2.500 (63.50)
			PK-70873-0918	X	71979-3807	X	71979-3907	X	71979-4007	(17.65)	(15.24)						71979-1827		71979-1927		71979-2027	2.695 (68.45)	2.600 (66.04)
8	16		PK-70873-0138		71979-1808		71979-1908		71979-2008	.795	.700		48		PK-70873-0138		71979-1828		71979-1928		71979-2028	2.795 (70.99)	2.700 (68.58)
			PK-70873-0918	X	71979-3808	X	71979-3908	X	71979-4008	(20.19)	(17.78)						71979-1829		71979-1929		71979-2029	2.895 (73.53)	2.800 (71.12)
9	18		PK-70873-0138		71979-1809		71979-1909		71979-2009	.895	.800		50		PK-70873-0138		71979-1830		71979-1930		71979-2030	2.995 (76.07)	2.900 (73.66)
			PK-70873-0918	X	71979-3809	X	71979-3909	X	71979-4009	(22.73)	(20.32)						71979-1831		71979-1931		71979-2031	3.095 (78.61)	3.000 (76.20)
10	20		PK-70873-0138		71979-1810		71979-1910		71979-2010	.995	.900		52		PK-70873-0138		71979-1832		71979-1932		71979-2032	3.195 (81.15)	3.100 (78.74)
			PK-70873-0918	X	71979-3810	X	71979-3910	X	71979-4010	(25.27)	(22.86)						71979-1833		71979-1933		71979-2033	3.295 (83.69)	3.200 (81.28)
11	22		PK-70873-0138		71979-1811		71979-1911		71979-2011	1.095	1.000		54		PK-70873-0138		71979-1834		71979-1934		71979-2034	3.395 (86.23)	3.300 (83.82)
			PK-70873-0918	X	71979-3811	X	71979-3911	X	71979-4011	(27.81)	(25.40)						71979-1835		71979-1935		71979-2035	3.495 (88.77)	3.400 (86.36)
12	24		PK-70873-0138		71979-1812		71979-1912		71979-2012	1.195	1.100		56		PK-70873-0138		71979-1836		71979-1936		71979-2036	3.595 (91.31)	3.500 (88.90)
			PK-70873-0918	X	71979-3812	X	71979-3912	X	71979-4012	(30.35)	(27.94)												
13	26		PK-70873-0138		71979-1813		71979-1913		71979-2013	1.295	1.200		58		PK-70873-0138								
			PK-70873-0918	X	71979-3813	X	71979-3913	X	71979-4013	(32.89)	(30.48)												
14	28		PK-70873-0138		71979-1814		71979-1914		71979-2014	1.395	1.300		60		PK-70873-0138								
			PK-70873-0918	X	71979-3814	X	71979-3914	X	71979-4014	(35.43)	(33.02)												
15	30		PK-70873-0138		71979-1815		71979-1915		71979-2015	1.495	1.400		62		PK-70873-0138								
			PK-70873-0918	X	71979-3815	X	71979-3915	X	71979-4015	(37.97)	(35.56)												
16	32		PK-70873-0138		71979-1816		71979-1916		71979-2016	1.595	1.500		64		PK-70873-0138								
			PK-70873-0918	X	71979-3816	X	71979-3916	X	71979-4016	(40.51)	(38.10)												
17	34		PK-70873-0138		71979-1817		71979-1917		71979-2017	1.695	1.600		66		PK-70873-0138								
			PK-70873-0918	X	71979-3817	X	71979-3917	X	71979-4017	(43.05)	(40.64)												
18	36		PK-70873-0138		71979-1818		71979-1918		71979-2018	1.795	1.700		68		PK-70873-0138								
			PK-70873-0918	X	71979-3818	X	71979-3918	X	71979-4018	(45.59)	(43.18)												
19	38		PK-70873-0138		71979-1819		71979-1919		71979-2019	1.895	1.800		70		PK-70873-0138								
			PK-70873-0918	X	71979-3819	X	71979-3919	X	71979-4019	(48.13)	(45.72)												

"X" INDICATES TOOLING IS NOT AVAILABLE.

REVISED
EC NO: S2009-0814
2009/09/01
DRWN:SKANG
2009/09/04
CHKD:ATSEE
2009/09/05
APPR:MLONG

QUALITY SYMBOLS
▽=0
◻=0

GENERAL TOLERANCES (UNLESS SPECIFIED)

	mm	INCH
4 PLACES	± ---	± ---
3 PLACES	± ---	± ---
2 PLACES	± ---	± .01
1 PLACE	± 0.25	± ---
ANGULAR ± 1/2°		

DRAFT WHERE APPLICABLE
MUST REMAIN
WITHIN DIMENSIONS

DIMENSION STYLE
IN/MM

SCALE
NTS

DESIGN UNITS
INCH

THIRD ANGLE PROJECTION

DRAWN BY: DJB DATE: 1995/03/15
CHECKED BY: DATE: 1995/03/15
APPROVED BY: DJB DATE: 1995/03/15

MATERIAL NO. SEE TABLE
DOCUMENT NO. SDA-71979-****
SHEET NO. 9 OF 12

THIS DRAWING CONTAINS INFORMATION THAT IS PROPRIETARY TO MOLEX INCORPORATED AND SHOULD NOT BE USED WITHOUT WRITTEN PERMISSION

NO. OF CKTS		OPTION D ASSEMBLY PLATINGS PER ES-88-**** (SEE SHEET 1 FOR PLATING SPECIFICATIONS)					DIMENSION			NO. OF CKTS		OPTION D ASSEMBLY PLATINGS PER ES-88-**** (SEE SHEET 1 FOR PLATING SPECIFICATIONS)					DIMENSION		
PER ROW	TOTAL		15 GOLD	30 GOLD	50 GOLD	A	B		PER ROW	TOTAL		15 GOLD	30 GOLD	50 GOLD	A	B			
4	8		7 1979-2604	7 1979-2704	7 1979-2804	.395 (10.03)	.300 (7.62)		34	68		7 1979-2634	7 1979-2734	7 1979-2834	3.395 (86.23)	3.300 (83.82)			
5	10		7 1979-2605	7 1979-2705	7 1979-2805	.495 (12.57)	.400 (10.16)		35	70		7 1979-2635	7 1979-2735	7 1979-2835	3.495 (88.77)	3.400 (86.36)			
6	12		7 1979-2606	7 1979-2706	7 1979-2806	.595 (15.1)	.500 (12.70)		36	72		7 1979-2636	7 1979-2736	7 1979-2836	3.595 (91.31)	3.500 (88.90)			
7	14		7 1979-2607	7 1979-2707	7 1979-2807	.695 (17.65)	.600 (15.24)												
8	16		7 1979-2608	7 1979-2708	7 1979-2808	.795 (20.19)	.700 (17.78)												
9	18		7 1979-2609	7 1979-2709	7 1979-2809	.895 (22.73)	.800 (20.32)												
10	20		7 1979-2610	7 1979-2710	7 1979-2810	.995 (25.27)	.900 (22.86)												
11	22		7 1979-2611	7 1979-2711	7 1979-2811	1.095 (27.81)	1.000 (25.40)												
12	24		7 1979-2612	7 1979-2712	7 1979-2812	1.195 (30.35)	1.100 (27.94)												
13	26		7 1979-2613	7 1979-2713	7 1979-2813	1.295 (32.89)	1.200 (30.48)												
14	28		7 1979-2614	7 1979-2714	7 1979-2814	1.395 (35.43)	1.300 (33.02)												
15	30		7 1979-2615	7 1979-2715	7 1979-2815	1.495 (37.97)	1.400 (35.56)												
16	32		7 1979-2616	7 1979-2716	7 1979-2816	1.595 (40.51)	1.500 (38.10)												
17	34		7 1979-2617	7 1979-2717	7 1979-2817	1.695 (43.05)	1.600 (40.64)												
18	36		7 1979-2618	7 1979-2718	7 1979-2818	1.795 (45.59)	1.700 (43.18)												
19	38		7 1979-2619	7 1979-2719	7 1979-2819	1.895 (48.13)	1.800 (45.72)												
20	40		7 1979-2620	7 1979-2720	7 1979-2820	1.995 (50.67)	1.900 (48.26)												
21	42		7 1979-2621	7 1979-2721	7 1979-2821	2.095 (53.21)	2.000 (50.80)												
22	44		7 1979-2622	7 1979-2722	7 1979-2822	2.195 (55.75)	2.100 (53.34)												
23	46		7 1979-2623	7 1979-2723	7 1979-2823	2.295 (58.29)	2.200 (55.88)												
24	48		7 1979-2624	7 1979-2724	7 1979-2824	2.395 (60.83)	2.300 (58.42)												
25	50		7 1979-2625	7 1979-2725	7 1979-2825	2.495 (63.37)	2.400 (60.96)												
26	52		7 1979-2626	7 1979-2726	7 1979-2826	2.595 (65.91)	2.500 (63.50)												
27	54		7 1979-2627	7 1979-2727	7 1979-2827	2.695 (68.45)	2.600 (66.04)												
28	56		7 1979-2628	7 1979-2728	7 1979-2828	2.795 (70.99)	2.700 (68.58)												
29	58		7 1979-2629	7 1979-2729	7 1979-2829	2.895 (73.53)	2.800 (71.12)												
30	60		7 1979-2630	7 1979-2730	7 1979-2830	2.995 (76.07)	2.900 (73.66)												
31	62		7 1979-2631	7 1979-2731	7 1979-2831	3.095 (78.61)	3.000 (76.20)												
32	64		7 1979-2632	7 1979-2732	7 1979-2832	3.195 (81.15)	3.100 (78.74)												
33	66		7 1979-2633	7 1979-2733	7 1979-2833	3.295 (83.69)	3.200 (81.28)												

NOTE: ALL CONNECTORS ARE PACKAGED IN TUBES PER PK-70873-0138

X INDICATES TOOLING IS NOT AVAILABLE.

REVISED
EC NO: S2009-0814
DRWN:SKANG
CHKD:ATSEE
APPR:MLONG
2009/09/01
2009/09/04
2009/09/05

QUALITY SYMBOLS
▽=0
◻=0

GENERAL TOLERANCES (UNLESS SPECIFIED)

	mm	INCH
4 PLACES	± ---	± ---
3 PLACES	± ---	± ---
2 PLACES	± ---	± .01
1 PLACE	± 0.25	± ---
ANGULAR ± 1/2°		

DRAFT WHERE APPLICABLE
MUST REMAIN
WITHIN DIMENSIONS

DIMENSION STYLE
IN/MM

DRAWN BY: DJB
DATE: 1995/03/15

CHECKED BY: DJB
DATE: 1995/03/15

APPROVED BY: DJB
DATE: 1995/03/15

MATERIAL NO. SEE TABLE

SCALE NTS
DESIGN UNITS INCH
THIRD ANGLE PROJECTION

TITLE
SMT RECEPTACLE
RIGHT ANGLE, DUAL ROW
WITH AND WITHOUT PEG

MOLEX MOLEX INCORPORATED

DOCUMENT NO. SDA-71979-****
SHEET NO. 10 OF 12

THIS DRAWING CONTAINS INFORMATION THAT IS PROPRIETARY TO MOLEX INCORPORATED AND SHOULD NOT BE USED WITHOUT WRITTEN PERMISSION

NO. OF CKTS		OPTION E ASSEMBLY PLATING PER ES-88-(****) (SEE SHEET 1 FOR PLATING SPECIFICATIONS)					DIMENSION		
PER ROW	TOTAL	15 GOLD	30 GOLD	50 GOLD	A	B			
4	8	71979-3004	71979-3104	71979-3204	.658 (16.71)	.300 (7.62)			
5	10	71979-3005	71979-3105	71979-3205	.758 (19.25)	.400 (10.16)			
6	12	71979-3006	71979-3106	71979-3206	.858 (21.79)	.500 (12.70)			
7	14	71979-3007	71979-3107	71979-3207	.958 (24.33)	.600 (15.24)			
8	16	71979-3008	71979-3108	71979-3208	1.058 (26.87)	.700 (17.78)			
9	18	71979-3009	71979-3109	71979-3209	1.158 (29.41)	.800 (20.32)			
10	20	71979-3010	71979-3110	71979-3210	1.258 (31.95)	.900 (22.86)			
11	22	71979-3011	71979-3111	71979-3211	1.358 (34.49)	1.000 (25.40)			
12	24	71979-3012	71979-3112	71979-3212	1.458 (37.03)	1.100 (27.94)			
13	26	71979-3013	71979-3113	71979-3213	1.558 (39.57)	1.200 (30.48)			
14	28	71979-3014	71979-3114	71979-3214	1.658 (42.11)	1.300 (33.02)			
15	30	71979-3015	71979-3115	71979-3215	1.758 (44.65)	1.400 (35.56)			
16	32	71979-3016	71979-3116	71979-3216	1.858 (47.19)	1.500 (38.10)			
17	34	71979-3017	71979-3117	71979-3217	1.958 (49.73)	1.600 (40.64)			
18	36	71979-3018	71979-3118	71979-3218	2.058 (52.27)	1.700 (43.18)			
19	38	71979-3019	71979-3119	71979-3219	2.158 (54.81)	1.800 (45.72)			
20	40	71979-3020	71979-3120	71979-3220	2.258 (57.35)	1.900 (48.26)			
21	42	71979-3021	71979-3121	71979-3221	2.358 (59.89)	2.000 (50.80)			
22	44	71979-3022	71979-3122	71979-3222	2.458 (62.43)	2.100 (53.34)			
23	46	71979-3023	71979-3123	71979-3223	2.558 (64.97)	2.200 (55.88)			
24	48	71979-3024	71979-3124	71979-3224	2.658 (67.51)	2.300 (58.42)			
25	50	71979-3025	71979-3125	71979-3225	2.758 (70.05)	2.400 (60.96)			
26	52	71979-3026	71979-3126	71979-3226	2.858 (72.59)	2.500 (63.50)			
27	54	71979-3027	71979-3127	71979-3227	2.958 (75.13)	2.600 (66.04)			
28	56	71979-3028	71979-3128	71979-3228	3.058 (77.67)	2.700 (68.58)			
29	58	71979-3029	71979-3129	71979-3229	3.158 (80.21)	2.800 (71.12)			
30	60	71979-3030	71979-3130	71979-3230	3.258 (82.75)	2.900 (73.66)			
31	62	71979-3031	71979-3131	71979-3231	3.358 (85.29)	3.000 (76.20)			
32	64	71979-3032	71979-3132	71979-3232	3.458 (87.83)	3.100 (78.74)			
33	66	71979-3033	71979-3133	71979-3233	3.558 (90.37)	3.200 (81.28)			

NO. OF CKTS		OPTION E ASSEMBLY PLATING PER ES-88-(****) (SEE SHEET 1 FOR PLATING SPECIFICATIONS)					DIMENSION		
PER ROW	TOTAL	15 GOLD	30 GOLD	50 GOLD	A	B			
34	68	71979-3034	71979-3134	71979-3234	3.658 (92.91)	3.300 (83.82)			
35	70	71979-3035	71979-3135	71979-3235	3.758 (95.45)	3.400 (86.36)			
36	72	71979-3036	71979-3136	71979-3236	3.858 (97.99)	3.500 (88.90)			

NOTE: ALL CONNECTORS ARE PACKAGED IN TUBES PER PK-70873-0139

"X" INDICATES TOOLING IS NOT AVAILABLE.

REVISED
EC NO: S2009-0814
DRWN:SKANG
CHKD:ATSEE
APPR:MLONG
2009/09/01
2009/09/04
2009/09/05

QUALITY SYMBOLS
▽=0
◻=0

GENERAL TOLERANCES (UNLESS SPECIFIED)

	mm	INCH
4 PLACES	± ---	± ---
3 PLACES	± ---	± ---
2 PLACES	± ---	± .01
1 PLACE	± 0.25	± ---
ANGULAR ± 1/2°		

DRAFT WHERE APPLICABLE
MUST REMAIN
WITHIN DIMENSIONS

DIMENSION STYLE
IN/MM

DRAWN BY: DJB
DATE: 1995/03/15

CHECKED BY: DJB
DATE: 1995/03/15

APPROVED BY: DJB
DATE: 1995/03/15

MATERIAL NO. SEE TABLE

SIZE: A3

SCALE: NTS

DESIGN UNITS: INCH

THIRD ANGLE PROJECTION

TITLE: SMT RECEPTACLE
RIGHT ANGLE, DUAL ROW
WITH AND WITHOUT PEG

MOLEX INCORPORATED

DOCUMENT NO. SDA-71979-****

SHEET NO. 11 OF 12

THIS DRAWING CONTAINS INFORMATION THAT IS PROPRIETARY TO MOLEX INCORPORATED AND SHOULD NOT BE USED WITHOUT WRITTEN PERMISSION

10		9		8		7		6		5		4		3		2		1					
NO. OF CKTS		OPTION F ASSEMBLY PLATING PER ES-88-(***) (SEE SHEET 1 FOR PLATING SPECIFICATIONS)						DIMENSION				NO. OF CKTS		OPTION F ASSEMBLY PLATING PER ES-88-(***) (SEE SHEET 1 FOR PLATING SPECIFICATIONS)						DIMENSION			
PER ROW	TOTAL	15 GOLD		30 GOLD		50 GOLD		A	B	C	PER ROW	TOTAL	15 GOLD		30 GOLD		50 GOLD		A	B	C		
4	8			71979-3404	71979-3504	71979-3604	.658 (16.71)	.300 (7.62)	.200 (5.08)		34	68			71979-3434	71979-3534	71979-3634	3.658 (92.91)	3.300 (83.82)	3.200 (81.28)			
5	10			71979-3405	71979-3505	71979-3605	.758 (19.25)	.400 (10.16)	.300 (7.62)		35	70			71979-3435	71979-3535	71979-3635	3.758 (95.45)	3.400 (86.36)	3.300 (83.82)			
6	12			71979-3406	71979-3506	71979-3606	.858 (21.79)	.500 (12.70)	.400 (10.16)		36	72			71979-3436	71979-3536	71979-3636	3.858 (97.99)	3.500 (88.90)	3.400 (86.36)			
7	14			71979-3407	71979-3507	71979-3607	.958 (24.33)	.600 (15.24)	.500 (12.70)														
8	16			71979-3408	71979-3508	71979-3608	1.058 (26.87)	.700 (17.78)	.600 (15.24)														
9	18			71979-3409	71979-3509	71979-3609	1.158 (29.41)	.800 (20.32)	.700 (17.78)														
10	20			71979-3410	71979-3510	71979-3610	1.258 (31.95)	.900 (22.86)	.800 (20.32)														
11	22			71979-3411	71979-3511	71979-3611	1.358 (34.49)	1.000 (25.40)	.900 (22.86)														
12	24			71979-3412	71979-3512	71979-3612	1.458 (37.03)	1.100 (27.94)	1.000 (25.40)														
13	26			71979-3413	71979-3513	71979-3613	1.558 (39.57)	1.200 (30.48)	1.100 (27.94)														
14	28			71979-3414	71979-3514	71979-3614	1.658 (42.11)	1.300 (33.02)	1.200 (30.48)														
15	30			71979-3415	71979-3515	71979-3615	1.758 (44.65)	1.400 (35.56)	1.300 (33.02)														
16	32			71979-3416	71979-3516	71979-3616	1.858 (47.19)	1.500 (38.10)	1.400 (35.56)														
17	34			71979-3417	71979-3517	71979-3617	1.958 (49.73)	1.600 (40.64)	1.500 (38.10)														
18	36			71979-3418	71979-3518	71979-3618	2.058 (52.27)	1.700 (43.18)	1.600 (40.64)														
19	38			71979-3419	71979-3519	71979-3619	2.158 (54.81)	1.800 (45.72)	1.700 (43.18)														
20	40			71979-3420	71979-3520	71979-3620	2.258 (57.35)	1.900 (48.26)	1.800 (45.72)														
21	42			71979-3421	71979-3521	71979-3621	2.358 (59.89)	2.000 (50.80)	1.900 (48.26)														
22	44			71979-3422	71979-3522	71979-3622	2.458 (62.43)	2.100 (53.34)	2.000 (50.80)														
23	46			71979-3423	71979-3523	71979-3623	2.558 (64.97)	2.200 (55.88)	2.100 (53.34)														
24	48			71979-3424	71979-3524	71979-3624	2.658 (67.51)	2.300 (58.42)	2.200 (55.88)														
25	50			71979-3425	71979-3525	71979-3625	2.758 (70.05)	2.400 (60.96)	2.300 (58.42)														
26	52			71979-3426	71979-3526	71979-3626	2.858 (72.59)	2.500 (63.50)	2.400 (60.96)														
27	54			71979-3427	71979-3527	71979-3627	2.958 (75.13)	2.600 (66.04)	2.500 (63.50)														
28	56			71979-3428	71979-3528	71979-3628	3.058 (77.67)	2.700 (68.58)	2.600 (66.04)														
29	58			71979-3429	71979-3529	71979-3629	3.158 (80.21)	2.800 (71.12)	2.700 (68.58)														
30	60			71979-3430	71979-3530	71979-3630	3.258 (82.75)	2.900 (73.66)	2.800 (71.12)														
31	62			71979-3431	71979-3531	71979-3631	3.358 (85.29)	3.000 (76.20)	2.900 (73.66)														
32	64			71979-3432	71979-3532	71979-3632	3.458 (87.83)	3.100 (78.74)	3.000 (76.20)														
33	66			71979-3433	71979-3533	71979-3633	3.558 (90.37)	3.200 (81.28)	3.100 (78.74)														

NOTE: ALL CONNECTORS ARE PACKAGED IN TUBES PER PK-70873-0139

"X" INDICATES TOOLING IS NOT AVAILABLE.

REVISED
EC NO: S2009-0814
DRWN:SKANG
CHKD:ATSEE
APPR:MLONG
2009/09/01
2009/09/04
2009/09/05

QUALITY SYMBOLS
▽=0
◻=0
DESCRIPTION
REV

GENERAL TOLERANCES (UNLESS SPECIFIED)
mm INCH
4 PLACES ± --- ± ---
3 PLACES ± --- ± ---
2 PLACES ± --- ± .01
1 PLACE ± 0.25 ± ---
ANGULAR ± 1/2°
DRAFT WHERE APPLICABLE
MUST REMAIN WITHIN DIMENSIONS

DIMENSION STYLE
IN/MM
DRAWN BY DATE
DJB 1995/03/15
CHECKED BY DATE
DJB 1995/03/15
APPROVED BY DATE
DJB 1995/03/15
MATERIAL NO.
SEE TABLE
SIZE
A3

SCALE
NTS
DESIGN UNITS
INCH
THIRD ANGLE PROJECTION
TITLE
SMT RECEPTACLE
RIGHT ANGLE, DUAL ROW
WITH AND WITHOUT PEG
MOLEX INCORPORATED
DOCUMENT NO.
SDA-71979-***
SHEET NO.
12 OF 12
THIS DRAWING CONTAINS INFORMATION THAT IS PROPRIETARY TO MOLEX
INCORPORATED AND SHOULD NOT BE USED WITHOUT WRITTEN PERMISSION