

9-CHANNEL LIGHT EFFECT LED DRIVER

DESCRIPTION

IS31FL3199 is a 9-channel light effect LED driver which features two-dimensional auto breathing mode and an audio modulated display mode. It has One Shot Programming mode and PWM Control mode for RGB lighting effects. The maximum output current can be adjusted in 8 levels (5mA~40mA).

FEATURES

- 2.7V to 5.5V supply voltage
- I2C interface, automatic address increment function
- Three groups RGB, single color LED breathing system-free pre-established pattern
- 9 independently controlled automatic and semiautomatic breathing system-free pre-established pattern
- 9 independently controlled outputs of 256 PWM steps
- 8 levels programmable output current
- Audio mode with AGC function
- Cascade for the synchronization of chips
- Over-temperature protection
- QFN-20 (3mm × 3mm) package

QUICK START



Figure 1: Photo of IS31FL3199 Evaluation Board

(Note: Old version EVB please refer to Appendix I)

RECOMMENDED EQUIPMENT

- 5.0V, 2A power supply

ABSOLUTE MAXIMUM RATINGS

- ≤ 5.5V power supply

Caution: Do not exceed the conditions listed above, otherwise the board will be damaged.

PROCEDURE

The IS31FL3199 evaluation board is fully assembled and tested. Follow the steps listed below to verify board operation.

Caution: Do not turn on the power supply until all connections are completed.

- 1) Short JP1 to connect by board MCU (default short).
- 2) Connect the 5VDC power to the connector (TP1&TP2) (Skip this step if use Micro-USB as power input).
- 3) Turn on the power supply/Plug in the Micro USB Pay attention to the supply current. If the current exceeds 1A, please check for circuit fault.

EVALUATION BOARD OPERATION

The IS31FL3199 evaluation board has five display modes. Press K1 to switch configurations.

- 1) 9 lamps breathe at the same time
- 2) The RGB monochromatic breathes
- 3) RGB audio mode
- 4) 9 lamps breathe one by one
- 5) 9 lamps audio mode

Note: IS31FL3199 solely controls the FxLED function on the evaluation board.

ORDERING INFORMATION

Part No.	Temperature Range	Package
IS31FL3199-QFLS2-EB	-40°C ~ +85°C (Industrial)	QFN-20, Lead-free

Table 1: Ordering Information

For pricing, delivery, and ordering information, please contact Lumissil's analog marketing team at analog@Lumissil.com or (408) 969-6600.

9-CHANNEL LIGHT EFFECT LED DRIVER

SOFTWARE CONTROL

J1 default setting is closed (short). If it is set to open, the MCU's SDB, SCL, SDA and CLK pin will be high impedance (open-drain) and external control is allowed.

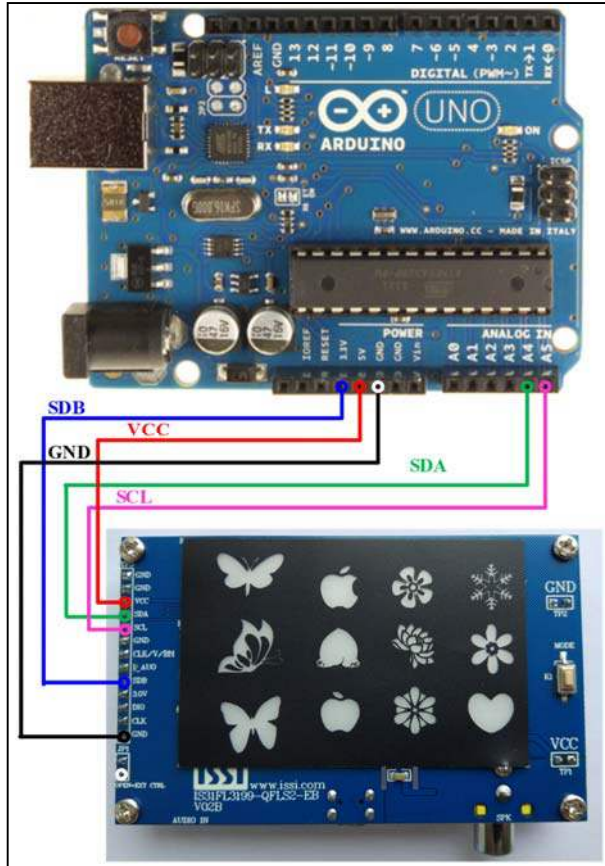

Figure 2: Photo of Arduino UNO connected to Evaluation Board

The steps listed below are an example using the Arduino for external control.

The Arduino hardware consists of an Atmel microcontroller with a bootloader allowing quick firmware updates. First download the latest Arduino Integrated Development Environment IDE (1.6.12 or greater) from www.arduino.cc/en/Main/Software. Also download the Wire.h library from www.arduino.cc/en/reference/wire and verify that pgmspace.h is in the directory ...program Files(x86)/Arduino/hardware/tools/avr/avr/include/avr/. Then download the latest IS31FL3199 test firmware (sketch) from the Lumissil website <http://www.lumissil.com/products/led-driver/fxled>.

- 1) Open JP1.
- 2) Connect the 5 pins from Arduino board to IS31FL3199 EVb:
 - a) Arduino 5V pin to IS31FL3199 EVb VCC.
 - b) Arduino GND to IS31FL3199 EVb GND.
 - c) Arduino SDA (A4) to IS31FL3199 EVb SDA.
 - d) Arduino SCL (A5) to IS31FL3199 EVb SCL.
 - e) If Arduino use 3.3V MCU VCC, connect 3.3V to IS31FL3199 EVb SDB, if Arduino use 5.0V MCU VCC, connect 5.0V to EVb SDB.
(Arduino UNO is 5.0V, so SDB=5.0V)
- 3) Use the test code in appendix I or download the test firmware (sketch) from the Lumissil website, a .txt file and copy the code to Arduino IDE, compile and upload to Arduino.
- 4) Run the Arduino code and the initial mode will change the RGB LED brightness every second. Note: the white color LEDs cannot be controlled when the onboard STM32F103C8T6 is disabled. (Some early board we provided is still controlling the white color LED, if want to switch between single color LED and RGB, remove the U4 and connect the VCC to the LED+)

Please refer to the datasheet to get more information about IS31FL3199.

9-CHANNEL LIGHT EFFECT LED DRIVER

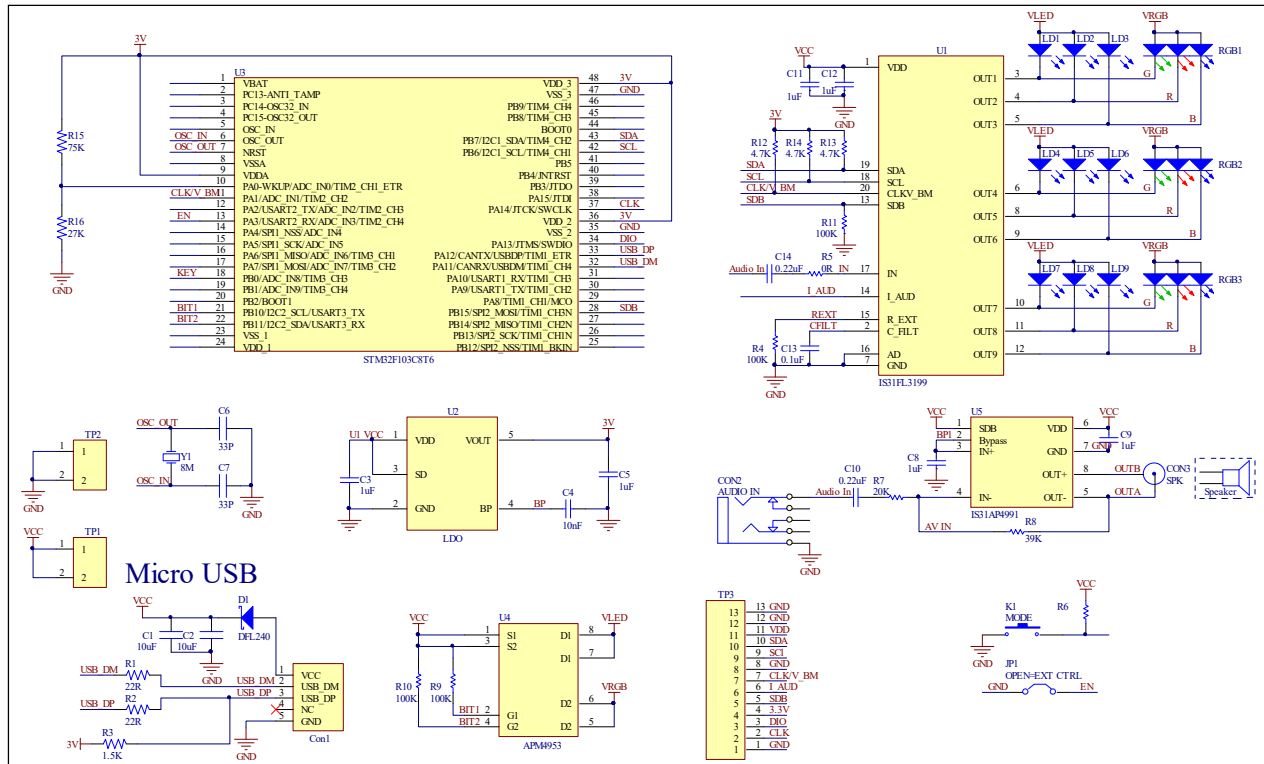

Figure 3: IS31FL3199 Application Schematic

9-CHANNEL LIGHT EFFECT LED DRIVER

BILL OF MATERIALS

Name	Symbol	Description	Qty	Supplier	Part No.
LED Driver	U1	Matrix LED Driver	1	Lumissil	IS31FL3199
LDO	U2	3.0V LDO	1	SGMICRO	SGM2019-3.0YN5G
MCU	U3	Microcontroller	1	STM	STM32F103C8T6
PMOS	U4	PMOS	1	ANPEC	APM4953
AMP	U5	Audio power amplifier	1	Lumissil	IS31AP4991
LED	LD1~LD9	Blue LED, SMD	9	Everlight	9-217/BHC-ZL1M2RY/3T
LED	RGB1~RGB3	RGB LED, SMD	3	Everlight	99-235/RSGBB7C-A22/2D or 99-235/RGBC/TR8
Diode	D1	Diode, SMD	1	Diodes In	DFLS240
Crystal	Y1	Crystal, 8MHz	1	HLX	HC-49S
Resistor	R1,R2	RES,22R,1/16W,±5%,SMD	2	Yageo	RC0603JR-0722RL
Resistor	R3	RES,1.5k,1/16W,±5%,SMD	1	Yageo	RC0603JR-071K5L
Resistor	R4,R6,R9, R10,R11	RES,100k,1/16W,±5%,SMD	5	Yageo	RC0603JR-07100KL
Resistor	R5	RES,0R,1/16W,±5%,SMD	1	Yageo	RC0603JR-07000KL
Resistor	R7	RES,20k,1/16W,±5%,SMD	1	Yageo	RC0603JR-0720KL
Resistor	R8	RES,39k,1/16W,±5%,SMD	1	Yageo	RC0603JR-0739KL
Resistor	R12,R13, R14	RES,4.7k,1/16W,±5%,SMD	3	Yageo	RC0603JR-0704K7L
Resistor	R15	RES,75k,1/16W,±5%,SMD	1	Yageo	RC0603JR-0775KL
Resistor	R16	RES,27k,1/16W,±5%,SMD	1	Yageo	RC0603JR-0727KL
Capacitor	C1,C2	CAP,10µF,16V,±20%,SMD	2	Yageo	CC0603KKX7R9BB106
Capacitor	C3,C5,C8, C9,C11	CAP,1µF,16V,±20%,SMD	5	Yageo	CC0603KKX7R9BB105
Capacitor	C4	CAP,10nF,16V,±20%,SMD	1	Yageo	CC0603KKX7R9BB103
Capacitor	C6,C7	CAP,33pF,16V,±20%,SMD	2	Yageo	CC0603KKX7R9BB330
Capacitor	C10,C14	CAP,0.22µF,16V,±20%,SMD	2	Yageo	CC0603KKX7R9BB224
Capacitor	C12,C13	CAP,0.1µF,16V,±20%,SMD	2	Yageo	CC0603KKX7R9BB104
Button	K1	Button SMD	1		

Bill of Materials, refer to Figure 3 above.

9-CHANNEL LIGHT EFFECT LED DRIVER

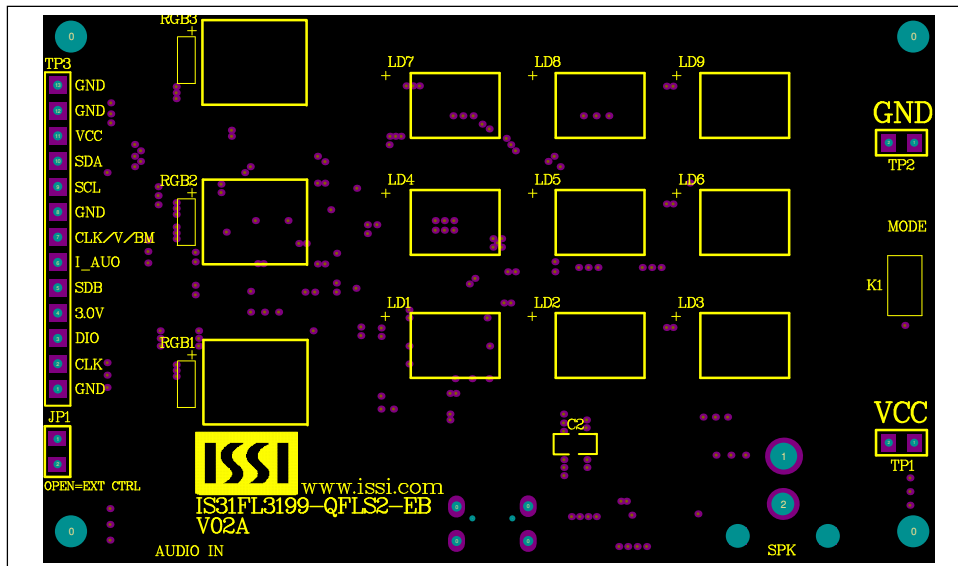

Figure 4: Board Component Placement Guide - Top Layer

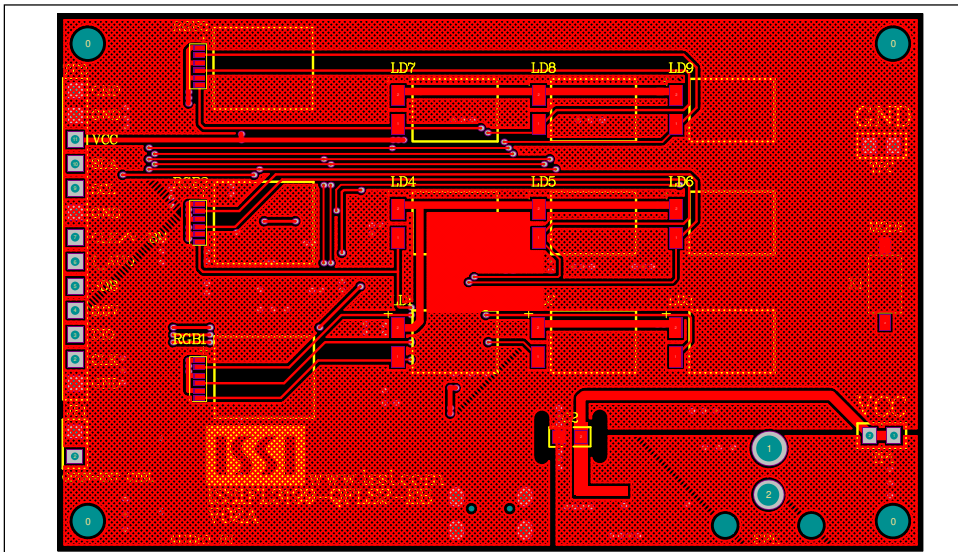

Figure 5: Board PCB Layout - Top Layer

9-CHANNEL LIGHT EFFECT LED DRIVER

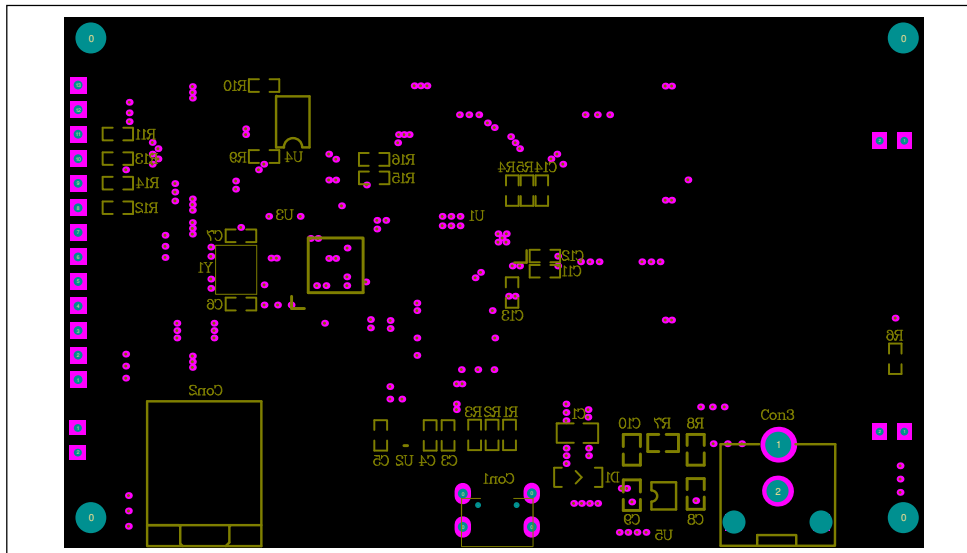

Figure 6: Board Component Placement Guide - Bottom Layer

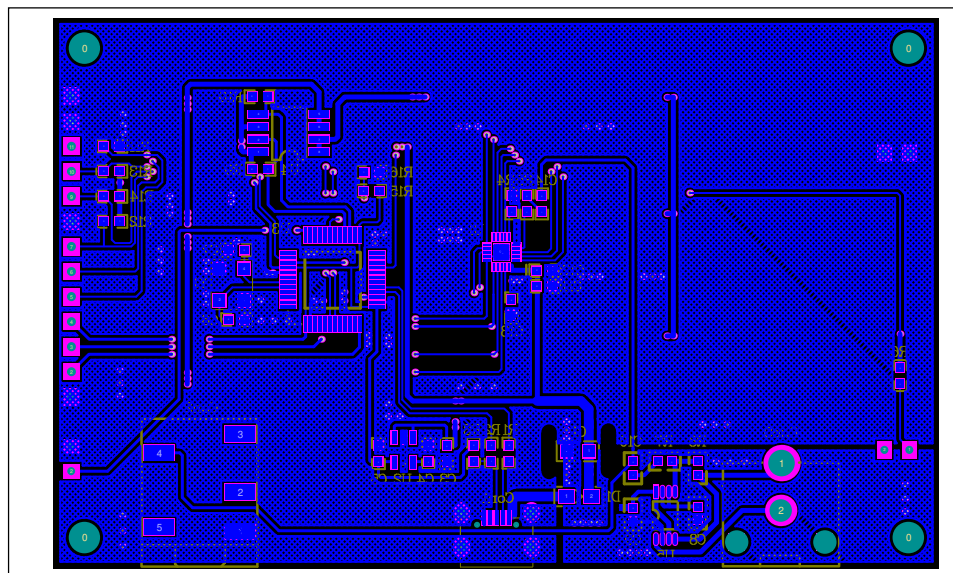

Figure 7: Board PCB Layout - Bottom Layer

Copyright © 2021 Lumissil Microsystems. All rights reserved. Lumissil Microsystems reserves the right to make changes to this specification and its products at any time without notice. Lumissil Microsystems assumes no liability arising out of the application or use of any information, products or services described herein. Customers are advised to obtain the latest version of this device specification before relying on any published information and before placing orders for products.

Lumissil Microsystems does not recommend the use of any of its products in life support applications where the failure or malfunction of the product can reasonably be expected to cause failure of the life support system or to significantly affect its safety or effectiveness. Products are not authorized for use in such applications unless Lumissil Microsystems receives written assurance to its satisfaction, that:

- a.) the risk of injury or damage has been minimized;
- b.) the user assume all such risks; and
- c.) potential liability of Lumissil Microsystems is adequately protected under the circumstances

9-CHANNEL LIGHT EFFECT LED DRIVER

REVISION HISTORY

Revision	Detail Information	Data
A	Initial release	2018.02.07
B	Update the BOM	2021.05.08

9-CHANNEL LIGHT EFFECT LED DRIVER

APPENDIX I: R1.0 GUIDE

DESCRIPTION

IS31FL3199 is a 9-channel light effect LED driver which features two-dimensional auto breathing mode and an audio modulated display mode. It has One Shot Programming mode and PWM Control mode for RGB lighting effects. The maximum output current can be adjusted in 8 levels (5mA~40mA).

The IS31FL3199 includes an audio modulated display mode, wherein the brightness of LED can be modulated by audio signal. There is a cascade pin for the synchronization of two chips.

FEATURES

- Supply voltage range from 3.0V to 5.5V
- I2C interface, automatic address increment function
- Three groups RGB, single color LED breathing system-free pre-established pattern
- 9 independently controlled automatic and semiautomatic breathing system-free pre-established pattern
- 9 independently controlled outputs of 256 PWM steps
- 8 levels programmable output current
- Audio mode with AGC function
- Package: QFN-20, 3mm × 3mm

QUICK START



Figure 8: Photo of IS31FL3199 Evaluation Board

RECOMMENDED EQUIPMENT

- 5.0V, 2A power supply
- Audio source(i.e. MP3 player, Notebook PC, etc)
- 8Ω speaker

ABSOLUTE MAXIMUM RATINGS

- ≤ 5.5V power supply

Caution: Do not exceed the above conditions; otherwise the board will be damaged.

PROCEDURE

The IS31FL3199 evaluation board is fully assembled and tested. Follow the steps listed below to verify board operation.

Caution: Do not turn on the power supply until all connections are completed.

- 1) Connect an 8Ω speaker to the “SPK” connector.
- 2) Connect the audio source to the “AUDIO IN” connector.
- 3) Connect the ground terminal of the power supply to the GND and the positive terminal to the VCC. Or connect the DC power to the connector (DC IN).
- 4) Turn on the power supply and pay attention to the supply current. If the current exceeds 1A, please check for circuit fault.
- 5) Turn on the audio signal.
- 6) Modulation of the audio signal utilized to obtain better sound output performance

EVALUATION BOARD OPERATION

The IS31FL3199 evaluation board has five display modes. Press MODE button to switch configurations.

- 1) Default Mode: 9 LEDs perform breath dimming effect.
- 2) 3 LEDs in one group: Single color breathing dimming. Each group performs dimming one by one, then three groups dim together.
- 3) 3 LEDs in one group: auto color changing following the rhythm of the input music.
- 4) 9 LEDs breathing dimming one followed by the other.
- 5) Breath dimming synchronized with the rhythm of the input music.

Note: IS31FL3199 solely controls the FxLED function on the evaluation board.

9-CHANNEL LIGHT EFFECT LED DRIVER

SOFTWARE CONTROL

Please refer to the integrated program.

JP1 default setting is close circuit. If it is set to open, the on-board MCU will stop working. The I2C pins are

set to High Impedance. External I2C signals can be connected to TP3 to control the IS31FL3199 LED driver.

Please refer to the datasheet for how to control the IS31FL3199.

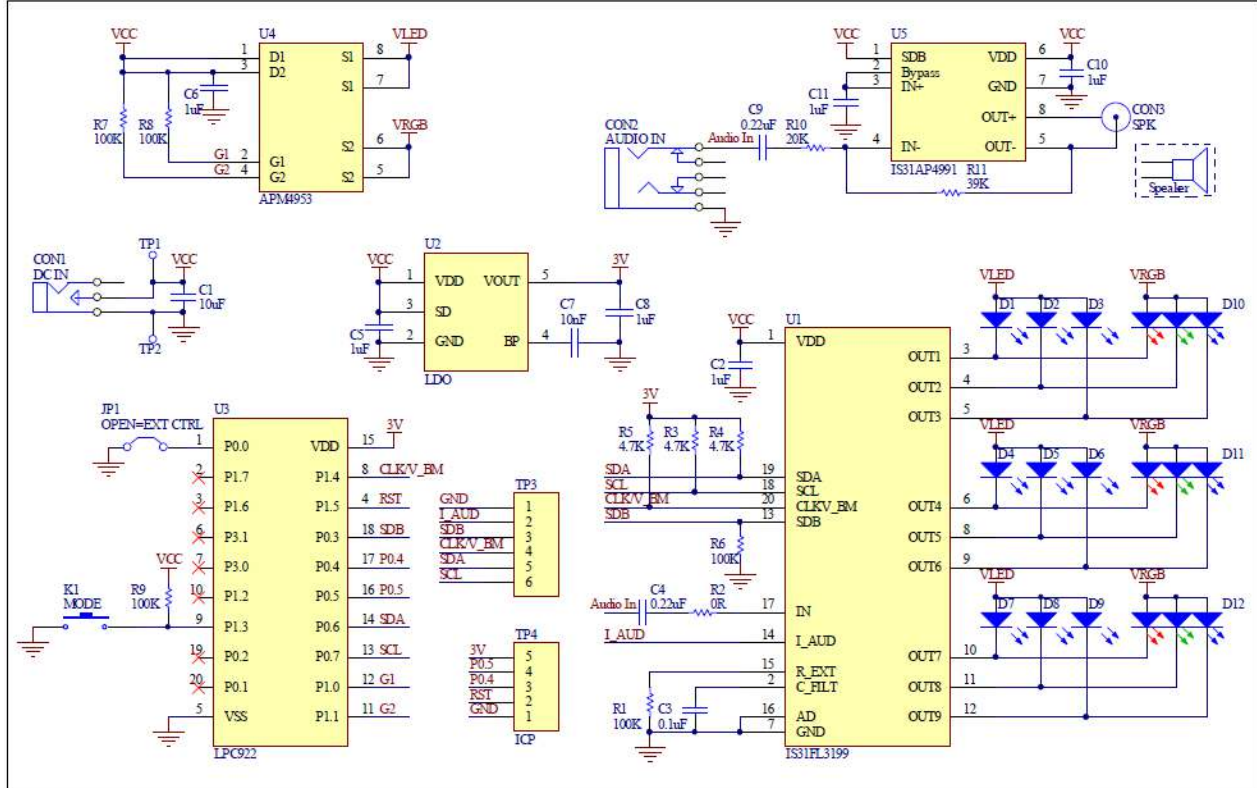

Figure 9: IS31FL3199 Application Schematic

9-CHANNEL LIGHT EFFECT LED DRIVER

BILL OF MATERIALS

Name	Symbol	Description	Qty	Supplier	Part No.
LED Driver	U1	9CH FxLED Driver	1	Lumissil	IS31FL3199
LDO	U2	Low-dropout Regulator	1	PAM	PAM3101
MCU	U3	Microcontroller	1	NXP	LPC922
PMOS	U4	Dual PMOS	1	ANPEC	APM4953
Audio Amplifier	U5	Class AB Audio Amplifier	1	Lumissil	IS31AP4991
Diode	D1,D5,D8	Diode, LED Blue, SMD	3	Everlight	19-217/BHC-ZL1M2RY/3T
Diode	D2,D9	Diode, LED Red, SMD	2	Everlight	19-217/BHC-ZL1M2RY/3T
Diode	D3,D6	Diode, LED Green, SMD	2	Everlight	19-217/BHC-ZL1M2RY/3T
Diode	D4,D7	Diode, LED White, SMD	2	Everlight	19-217/BHC-ZL1M2RY/3T
Diode	D10~D12	Diode, LED RGB, SMD	3	Everlight	99-235/RSGBB7C-A22/2D or 99-235/RGBC/TR8
Resistor	R1,R6,R7, R8,R9	RES,100k,1/16W,±5%,SMD	5		
Resistor	R2	RES,0R,1/16W,±5%,SMD	1		
Resistor	R3~R5	RES,4.7k,1/16W,±5%,SMD	3		
Resistor	R10	RES,20k,1/16W,±5%,SMD	1		
Resistor	R11	RES,39k,1/16W,±5%,SMD	1		
Capacitor	C1	CAP,10µF,16V,±20%,SMD	1		
Capacitor	C2,C5,C6 C8,C10,C11	CAP,1µF,16V,±20%,SMD	6		
Capacitor	C3	CAP,0.1µF,16V,±20%,SMD	1		
Capacitor	C4	CAP,0.22µF,16V,±20%,SMD	1		
Capacitor	C7	CAP,10nF,16V,±20%,SMD	1		
Button	K1	Button SMD	1		

Bill of Materials, refer to Figure 9 above.

9-CHANNEL LIGHT EFFECT LED DRIVER

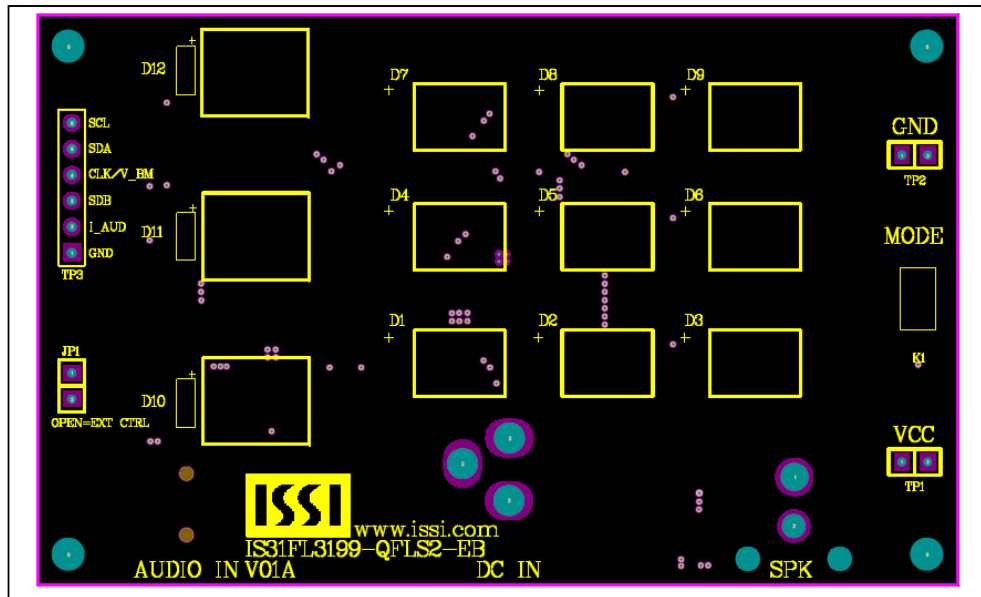

Figure 10: Board Component Placement Guide - Top Layer

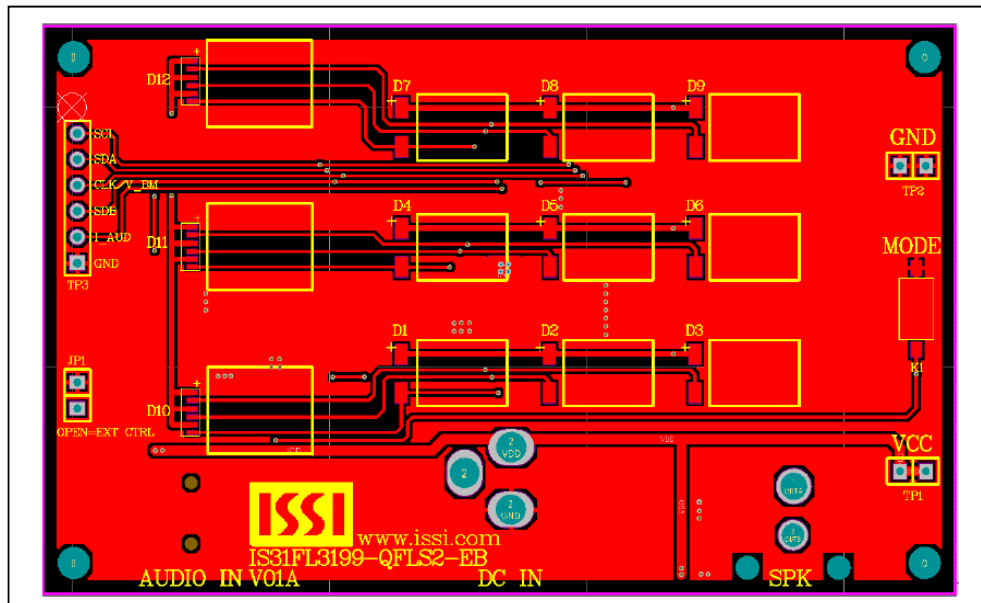

Figure 11: Board PCB Layout - Top Layer

9-CHANNEL LIGHT EFFECT LED DRIVER

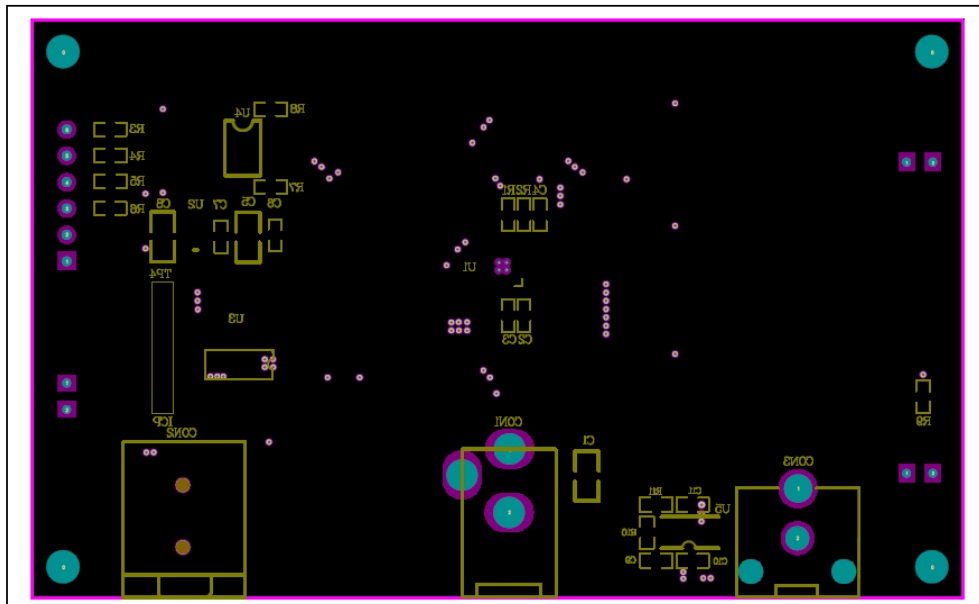

Figure 12: Board Component Placement Guide - Bottom Layer

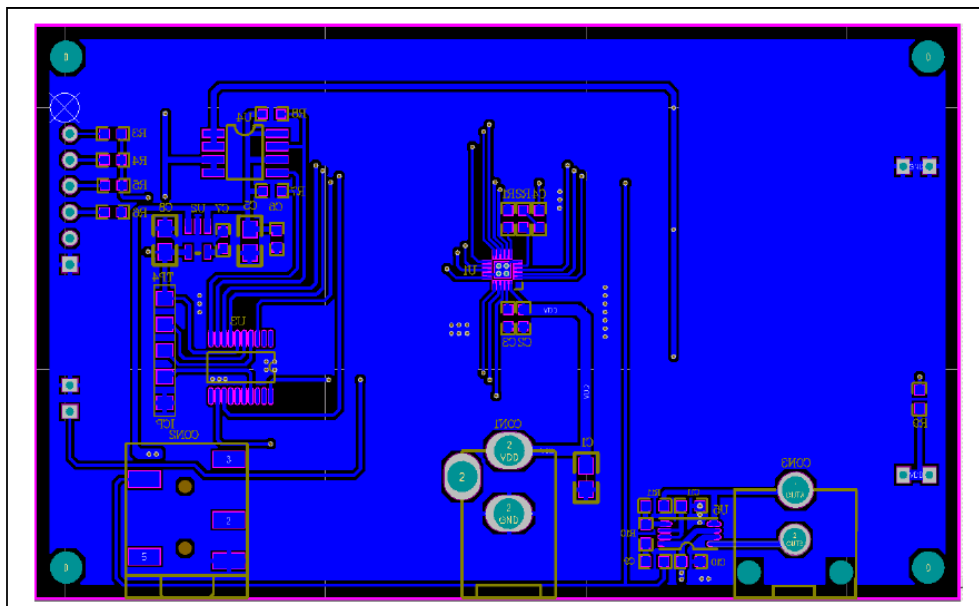

Figure 13: Board PCB Layout - Bottom Layer

9-CHANNEL LIGHT EFFECT LED DRIVER

APPENDIX II: IS31FL3199 Arduino Test Code V01A

```

#include<Wire.h>
#include<avr/pgmspace.h>
#define Addr_GND  0xC8//7 bit format is 0x64
#define Addr_VCC  0xCE//7 bit format is 0x67
#define Addr_SCL  0xCA//7 bit format is 0x65
#define Addr_SDA  0xCC//7 bit format is 0x66

int i,j;

byte PWM_Gamma64[64]=
{
  0x00,0x01,0x02,0x03,0x04,0x05,0x06,0x07,
  0x08,0x09,0x0b,0x0d,0x0f,0x11,0x13,0x16,
  0x1a,0x1c,0x1d,0x1f,0x22,0x25,0x28,0x2e,
  0x34,0x38,0x3c,0x40,0x44,0x48,0x4b,0x4f,
  0x55,0x5a,0x5f,0x64,0x69,0x6d,0x72,0x77,
  0x7d,0x80,0x88,0x8d,0x94,0x9a,0xa0,0xa7,
  0xac,0xb0,0xb9,0xbf,0xc6,0xcb,0xcf,0xd6,
  0xe1,0xe9,0xed,0xf1,0xf6,0xfa,0xfe,0xff
};

void setup() {
  // put your setup code here, to run once:
  Wire.begin();
  Wire.setClock(400000);//I2C 400kHz
  // pinMode(4,OUTPUT);//SDB
  // digitalWrite(4,HIGH);//SDB_HIGH
  IS31FL3199_mode2();
}

void loop()
{
  // put your main code here, to run repeatedly:
  //IS31FL3199_mode1();
  //PWM mode, if enable this mode, need to disable
  //IS31FL3199_mode2();
}

void IS_IIC_WriteByte(uint8_t Dev_Add,uint8_t Reg_Add,uint8_t Reg_Dat)
{
  Wire.beginTransmission(Dev_Add/2);
  Wire.write(Reg_Add); // sends regaddress
  Wire.write(Reg_Dat); // sends regaddress
  Wire.endTransmission(); // stop transmitting
}

void Init_FL3199(void)
{
  IS_IIC_WriteByte(Addr_GND,0x00,0x01);//normal operation
  IS_IIC_WriteByte(Addr_GND,0x01,0x77);//on/off
  IS_IIC_WriteByte(Addr_GND,0x21,0x07);//on/off
  IS_IIC_WriteByte(Addr_GND,0x03,0x00);
  IS_IIC_WriteByte(Addr_GND,0x04,0x00);
  for(i=0x07;i<0x0F;i++){IS_IIC_WriteByte(Addr_GND, i, 0x00);}//PWM data
  IS_IIC_WriteByte(Addr_GND, 0x10, 0x00);//update
}

void Rgb_Pwm_Control_FL3199(uint8_t datx,uint8_t datR,uint8_t datG,uint8_t datB)//datx RGBx
{
  switch(datx)
  {
    case 1:IS_IIC_WriteByte(Addr_GND, 0x07, datG);//set out1 pwm  G
            IS_IIC_WriteByte(Addr_GND, 0x08, datR);//set out2 pwm  R
            IS_IIC_WriteByte(Addr_GND, 0x09, datB);//set out3 pwm  B
            break;
    case 2:IS_IIC_WriteByte(Addr_GND, 0x0A, datG);//set out4 pwm  G
            IS_IIC_WriteByte(Addr_GND, 0x0B, datR);//set out5 pwm  R
            IS_IIC_WriteByte(Addr_GND, 0x0C, datB);//set out6 pwm  B
            break;
    case 3:IS_IIC_WriteByte(Addr_GND, 0x0D, datG);//set out7 pwm  G
            IS_IIC_WriteByte(Addr_GND, 0x0E, datR);//set out8 pwm  R
            IS_IIC_WriteByte(Addr_GND, 0x0F, datB);//set out9 pwm  B
  }
}

```

9-CHANNEL LIGHT EFFECT LED DRIVER

```

        break;
        default:break;
    }
    IS_IIC_WriteByte(Addr_GND, 0x10, 0x00);//update PWM registers
}

void IS31FL3199_mode1(void)//need to run in loop
{
    Init_FL3199();
    for (j=0;j<64;j++)//all LED ramping up
    {
        Rgb_Pwm_Control_FL3199(1, PWM_Gamma64[j],PWM_Gamma64[j],PWM_Gamma64[j]);
        Rgb_Pwm_Control_FL3199(2, PWM_Gamma64[j],PWM_Gamma64[j],PWM_Gamma64[j]);
        Rgb_Pwm_Control_FL3199(3, PWM_Gamma64[j],PWM_Gamma64[j],PWM_Gamma64[j]);
        delay(10);//10ms
    }
    delay(1000); //keep on 1s
    for (j=63;j>=0;j--)//all LED ramping down
    {
        Rgb_Pwm_Control_FL3199(1, PWM_Gamma64[j],PWM_Gamma64[j],PWM_Gamma64[j]);
        Rgb_Pwm_Control_FL3199(2, PWM_Gamma64[j],PWM_Gamma64[j],PWM_Gamma64[j]);
        Rgb_Pwm_Control_FL3199(3, PWM_Gamma64[j],PWM_Gamma64[j],PWM_Gamma64[j]);
        delay(10);//10ms
    }
    delay(1000); //keep off 1s
}
void IS31FL3199_mode2(void)//One shot mode, only in setup
{
    //Init_FL3199();
    IS_IIC_WriteByte(Addr_GND,0x00,0x01);//normal operation
    IS_IIC_WriteByte(Addr_GND,0x01,0x77);//on/off
    IS_IIC_WriteByte(Addr_GND,0x02,0x07);//on/off
    IS_IIC_WriteByte(Addr_GND,0x03,0x70);//One shot mode
    IS_IIC_WriteByte(Addr_GND,0x04,0x00);

    IS_IIC_WriteByte(Addr_GND,0x07,0xff);//PWM
    IS_IIC_WriteByte(Addr_GND,0x08,0xff);
    IS_IIC_WriteByte(Addr_GND,0x09,0xff);
    IS_IIC_WriteByte(Addr_GND,0x0a,0xff);
    IS_IIC_WriteByte(Addr_GND,0x0b,0xff);
    IS_IIC_WriteByte(Addr_GND,0x0c,0xff);
    IS_IIC_WriteByte(Addr_GND,0x0d,0xff);
    IS_IIC_WriteByte(Addr_GND,0x0e,0xff);
    IS_IIC_WriteByte(Addr_GND,0x0f,0xff);
    IS_IIC_WriteByte(Addr_GND,0x10,0x00);//update PWM registers

    IS_IIC_WriteByte(Addr_GND,0x11,0x00);//T0
    IS_IIC_WriteByte(Addr_GND,0x12,0x01);
    IS_IIC_WriteByte(Addr_GND,0x13,0x02);
    IS_IIC_WriteByte(Addr_GND,0x14,0x05);
    IS_IIC_WriteByte(Addr_GND,0x15,0x04);
    IS_IIC_WriteByte(Addr_GND,0x16,0x03);
    IS_IIC_WriteByte(Addr_GND,0x17,0x06);
    IS_IIC_WriteByte(Addr_GND,0x18,0x07);
    IS_IIC_WriteByte(Addr_GND,0x19,0x09);

    IS_IIC_WriteByte(Addr_GND,0x1a,0xa0);//T1~T3
    IS_IIC_WriteByte(Addr_GND,0x1b,0xa0);
    IS_IIC_WriteByte(Addr_GND,0x1c,0xa0);

    IS_IIC_WriteByte(Addr_GND,0x1d,0x07);//T4
    IS_IIC_WriteByte(Addr_GND,0x1e,0x07);
    IS_IIC_WriteByte(Addr_GND,0x1f,0x07);
    IS_IIC_WriteByte(Addr_GND,0x20,0x07);
    IS_IIC_WriteByte(Addr_GND,0x21,0x07);
    IS_IIC_WriteByte(Addr_GND,0x22,0x07);
    IS_IIC_WriteByte(Addr_GND,0x23,0x07);
    IS_IIC_WriteByte(Addr_GND,0x24,0x07);
    IS_IIC_WriteByte(Addr_GND,0x25,0x07);

    IS_IIC_WriteByte(Addr_GND,0x26,0x00);
    IS_IIC_WriteByte(Addr_GND,0x03,0x70);//One shot mode
}

```