

MDM293 OEM Differential Pressure Sensor



Features

- Pressure Range: 0bar~2bar...35bar
- Constant current or constant voltage power supply
- Isolated Construction, enable to measure various media
- OEM differential pressure sensor
- Full stainless steel 316L
- High static pressure 200bar

Application

- Industrial process control
- Differential pressure detection
- Gas, Liquid pressure measure
- Pressure checking meter
- Pressure calibrator
- Venturi and Vortex flow meters

Introduction

MDM293 OEM differential pressure sensor is an OEM differential pressure measuring element isolated by stainless steel corrugated diaphragm. Small size, high static pressure resistance, stable and reliable. Both the high and low pressure ends are protected by isolation diaphragms. Both pressure chambers can be exposed to a certain corrosive fluid medium. The measured differential pressure is transmitted to the silicon pressure-sensitive element through the isolation diaphragm and the filled silicone oil, realizing the accurate measurement of differential pressure. It selects the high-precision and high-stability diffusion silicon piezoresistive pressure sensitive chip produced by a famous international manufacturer. The pressure sensitive component is assembled on the automatic production line and tested and compensated by the computer automatically. It has high accuracy and good stability. It can be widely used in industrial process control and other fields to measure differential pressure.

Electrical Performance

- Power Supply: $\leq 2.0\text{mA DC}$
- Electrical Connection: 100mm silicon rubber flexible wires
- Common mode voltage output: 50% of input (typ.)
- Input Impedance: $2\text{k}\Omega\sim 5\text{k}\Omega$
- Output Impedance: $3.5\text{k}\Omega\sim 6\text{k}\Omega$
- Response (10%~90%): $< 1\text{ms}$
- Insulation Resistor: $100\text{M}\Omega@100\text{V DC}$
- Maximum Static Pressure: 200bar
- Zero Drift or Static Pressure: $\leq 0.05\text{mV}/\text{bar}$

Construction Performance

- Diaphragm: Stainless steel 316L
- Housing: Stainless steel 316L
- Pin: 100mm silicon rubber flexible wires
- O-ring: FKM
- Net weight: $\sim 20\text{g}$

Environment Condition

- Shock: No change at 10gRMS, (20~2000)Hz
- Impact: 100g, 11ms
- Media compatibility: Liquid or gas compatible with stainless steel and FKM

Basic Condition

- Media temperature: (35±1)°C
- Environment temperature: (35±1)°C
- Shock: 0.1g (1m/s²) Max
- Humidity: (50±10)%RH
- Atmospheric pressure: (0.86~1.06)bar
- Power supply: (1.5±0.0015) mA DC

Specification

Item*	Min.	Typ.	Max.	Units
Linearity		±0.15	±0.25	%FS,BFSL
Repeatability		±0.05	±0.075	%FS
Hysteresis		±0.05	±0.075	%FS
Zero output			±3.0	mV DC
Output/Span**	60			mVDC
Zero thermal error		±0.75	±1.0	%FS, @35°C
Span thermal error		±0.75	±1.0	%FS, @35°C
Compensated temp. range		0 ~ 70		°C
Working temp. range		-40 ~ 125		°C
Storage temp. range		-40 ~ 125		°C
Stability error		±0.3	±0.5	%FS/Year

* testing at basic condition
 ** Output/Span=full scale output - zero point

Outline Construction

Unit: mm

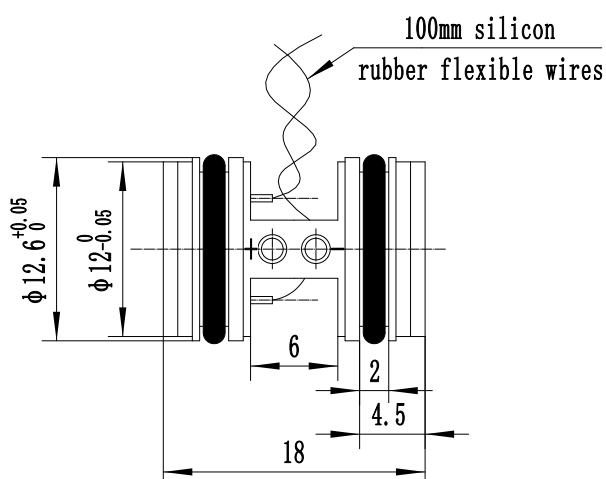

The suggested mounting dimension is $\phi 12.6^{+0.12}_{+0.08}$ mm

Electrical Connection

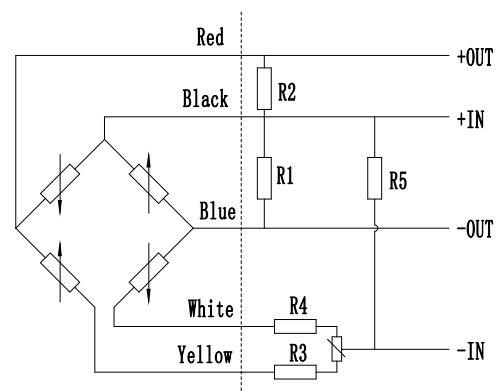

Wire color	Definition
Black	+IN
Yellow	-IN
White	-IN
Red	+OUT
Blue	-OUT

Notes

1. The resistance bridge circuit with arrows on the left side of the dashed line is the bridge circuit of the sensitive chip.
2. Without ceramic compensation board, an external resistor must be connected to compensate the zero point and temperature drift. The connection is shown in the figure. Connect the zero-adjusting resistor R3 (R4), the other resistor R4 (R3) is short-circuited as the negative power supply; R1 or R2 is the zero temperature drift compensation resistor, only one is used, the other is open, according to the information provided by the parameter card To choose; R5 is the sensitivity temperature compensation resistor. When using, it is recommended to connect the external compensation resistor as close as possible to the differential pressure sensitive element.

Order Guide

MDM293		OEM differential pressure sensor			
		Range code	Pressure range	Range code	Pressure range
		07	0bar~2bar	10	0bar~10bar
		08	0bar~3.5bar	12	0bar~20bar
		09	0bar~7bar	13	0bar~35bar
		Code	Compensation		
		M	Provide compensation resistance		
		Code	Electrical connection100mm silicon rubber flexible wires		
		2	100mm silicon rubber flexible wires		
MDM293	12	M	2	the whole spec	

Notes

1. The default unit of all the products is kPa (1kPa=0.01bar).
2. One end of the lead wire on the sensitive component is the high end, and the other end is the low end. The high and low terminals can also be identified by the "+" and "-" marks on the sensitive components. During use, the pressure applied to the high-pressure end should generally not be lower than the pressure applied to the low-pressure end.
3. Pay attention to protect the isolation diaphragm of sensitive components to prevent any irreversible deformation.
4. Do pull the 6 flexible wires of sensitive components.
5. Temperature resistant range of standard FKM O-ring of sensor is 20 °C ~ 250 °C . When the working temperature is lower than -20 °C , or sensor is applied in critical environment, please contact us.