



SPECIFICATION FOR AUTOMOTIVE SPEAKER

TOTAL PAGE 08

www.be-star.com

RoHS

Customer		Model Name	BDT3032H12.8-03 LF
Customer P/N		Product No.	060310
Date	29 November. 16	Issue No.	BS/TES01.461F
Page	01 of 08	Issue Date	16/11/29

Approval:

- 1.Characteristics
- 2.Notice
- 3.Dimension
- 4.Bill of Material
- 5.Reliability Test
- 6.Packing
- 7.History change record

Drawn by	Checked by	Approved by	Customer approved
邱蒙 2016.11.29	魏奉玲 2016.11.29	姚利明 2016.11.29	

BESTAR HOLDING CO.,LTD

No.199 HuangHe West Road,New district,ChangZhou,JiangSu Province,P.R.China

Tel: +86 519 88222567 **Fax:** +86 519 88222551

E-mail:wu@be-star.com **http://**www.bestargroups.com

BDT3032H12.8-03 LF



1. Characteristic

1.1 Electrical and Mechanical Characteristics

No.	Item	Specifications
1.	Impedance *(2kHz)	32ohm± 10%
2.	Rated Input Power	1.3W
3.	Max. Input Power	1.5W
4.	Operating Voltage	
	Impulse voltage,square wave,duty cycle 50%,symmetric	6-12.8Vp-p
	Impulse voltage,square wave,duty cycle 50%,symmetric	4-9Vop
5.	Output SPL Values are shown in table1,The sound pressure level is measured according to the test assembly shown in picture1.	
6.	Frequency range	1000Hz to 4000Hz
7.	Operating Temperature	-40...+105°C
8.	Storage Temperature	-40...+105°C
9.	Weight	11g
10.	Voice coil	Ø0.045 Cu (self-bonding hot air)
11.	Break down voltage between pin and housing	> 5kV

picture 1

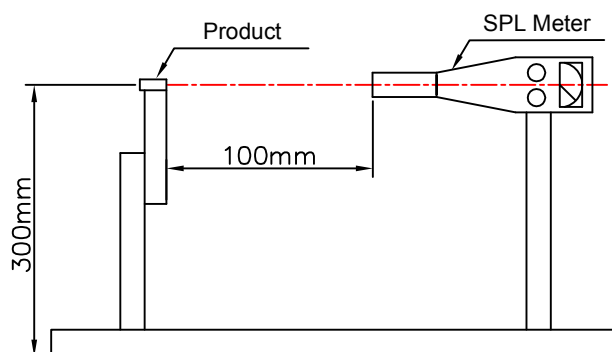

This print and information there in are proprietary to BeStar Holding Co., Ltd. and shall not be used in whole or in part without its written content.

				Date:	16/ 11/29	BDT3032H12.8-03 LF	
F	16/11/29	邱蒙		Drawn by:	邱蒙		
A	07/08/09	莫丽丽		Checked by:	魏奉玲	Speaker	
Rev.	Date	Drawn	Note	Approved by:	姚利明		
BESTAR HOLDING CO.,LTD						DRG NO: BS/TES01.461F	Page:02 of 08
www.bestargroups.com wu@be-star.com							

BDT3032H12.8-03 LF

table 1

Frequency /Hz	Min SPL /dBA	Max SPL /dBA
720	88	98
750	88	98
900	88	98
1000	90	100
1600	98	108
1900	95	105
2000	95	105

Test conditions

The test assembly is in free field or a test room with min 2m ×2m ground and 2m high
 Distance between loudspeaker and SPL meter=10cm
 Trigger voltage is 5.6Vp-p, 50% duty square wave signal
 The trigger signal comes from a function generator FG100. The trigger voltage is adjusted to 5.6Vp-p constant voltage.(in case of load)

1.2 Frequency response curve(sine wave 0.15W,10cm testing)

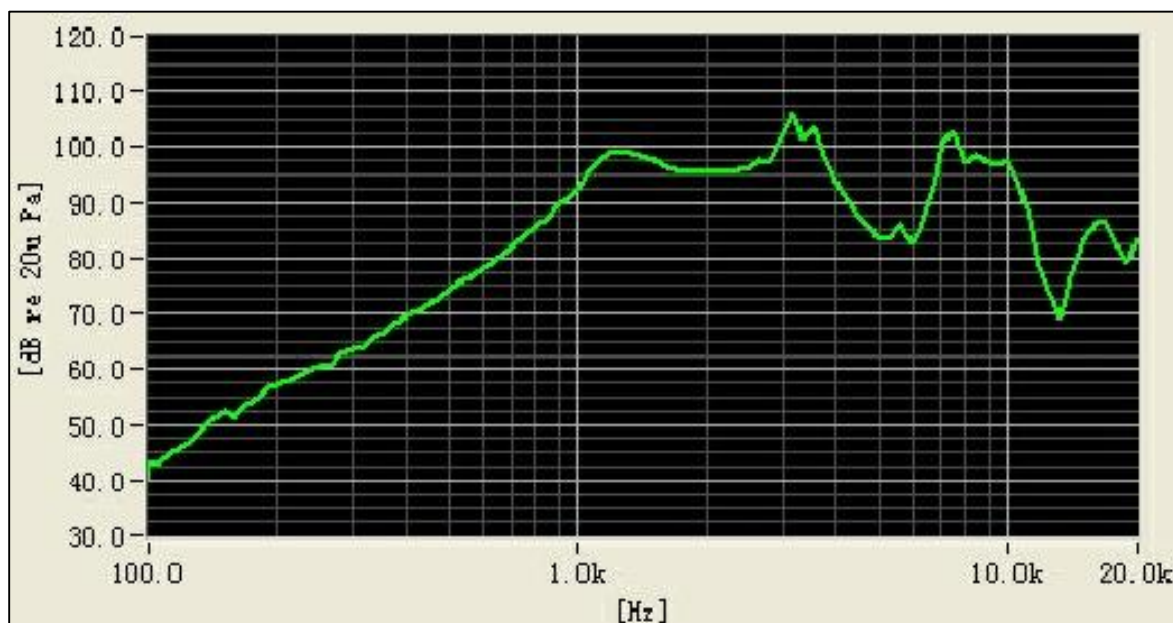

This print and information there in are proprietary to BeStar Holding Co., Ltd. and shall not be used in whole or in part without its written content

				Date:	16/ 11/29	BDT3032H12.8-03 LF	
F	16/ 11/29	邱蒙		Drawn by:	邱蒙		
A	07/08/09	莫丽丽		Checked by:	魏奉玲	Speaker	
Rev.	Date	Drawn	Note	Approved by:	姚利明		
BESTAR HOLDING CO.,LTD						DRG NO: BS/TES01.461F	Page:03 of 08
www.bestargroups.com wu@be-star.com							

BDT3032H12.8-03 LF

2. Notice

2.1 Storage Condition

The products should be stored in the room, where the temperature/humidity is stable. And avoid such places where there are large temperature changes. Please store the products at the following conditions:

Temperature: -10 to + 40 °C Humidity: 15 to 85% R.H.

2.2 Expire Date on Storage

Expire date (Shelf life) of the products is six months after delivered under the conditions of a sealed and an unopened package. Please use the products within six months after delivered.

If you store the products for a long time (more than six months), use carefully because the products may be degraded in the solderability and/or rusty. Please confirm solderability and characteristics for the products regularly.

2.3 Notice on Product Storage

(1) Please do not store the products in a chemical atmosphere (Acids, Alkali, Bases, Organic gas, Sulfides and so on), because the characteristics may be reduced at quality, and/or be degraded in the solderability due to the storage in a chemical atmosphere.

(2) Please use the products immediately after the package is opened, because the characteristics may be reduced at quality, and/or be degraded in the solderability due to storage under the poor condition.

3. Dimension

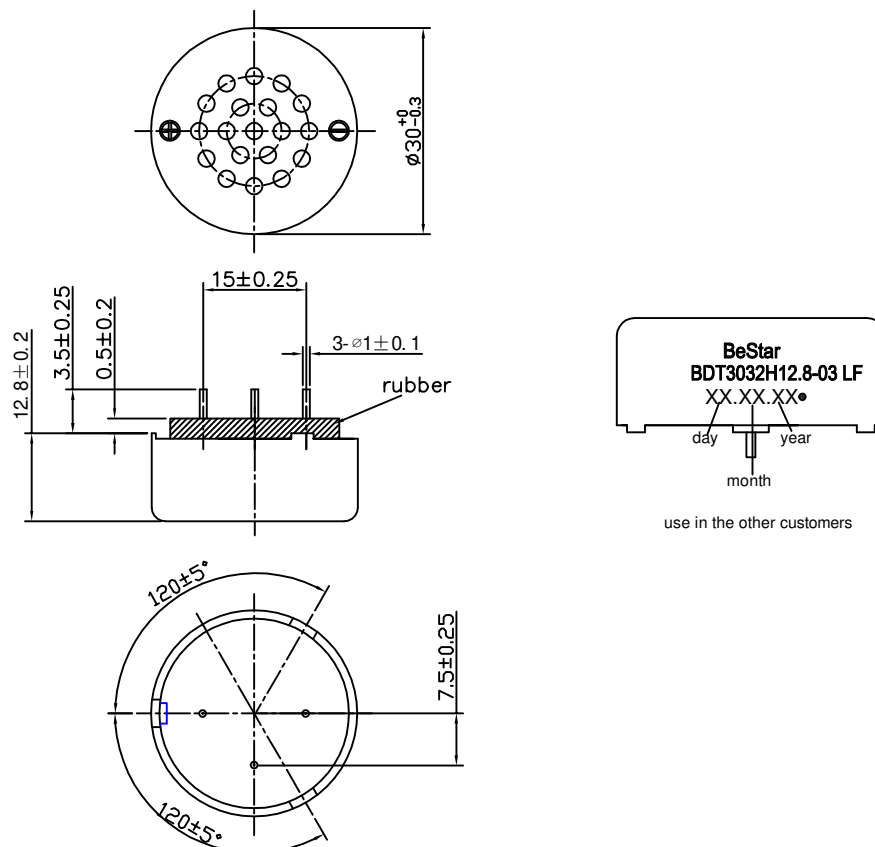

This print and information there in are proprietary to BeStar Holding Co., Ltd. and shall not be used in whole or in part without its written content

				Date:	16/ 11/29	BDT3032H12.8-03 LF
F	16/ 11/29	邱蒙		Drawn by:	邱蒙	
A	07/08/09	莫丽丽		Checked by:	魏奉玲	Speaker
Rev.	Date	Drawn	Note	Approved by:	姚利明	
BESTAR HOLDING CO.,LTD						DRG NO: BS/TES01.461F
www.bestargroups.com wu@be-star.com						Page:04 of 08

BDT3032H12.8-03 LF

4. Bill of Material

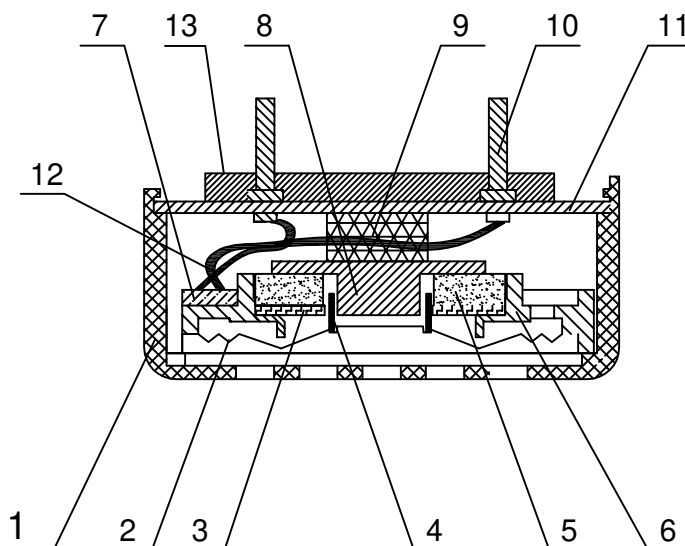

13	mat	Rubber
12	Connect wire	Cu and PVC
11	Plugboard	Epoxy and Cu
10	Pin	CuΦ1.0 (plating tin)
9	Mat	Sponge
8	Yoke	SPCC
7	PCB	Epoxy and Cu
6	Frame	Plastic MPPO+20%GF
5	Magnet	Nd-Fe-B N35H
4	Voice Coil	∅0.045 Cu
3	Piece	SPCC
2	Diaphragm	PEI
1	Housing	Plastic MPPO+20%GF
No	Parts Name	Material

				Date:	16/ 11/29	BDT3032H12.8-03 LF		
F	16/ 11/29	邱蒙		Drawn by:	邱蒙			
A	07/08/09	莫丽丽		Checked by:	魏奉玲			Speaker
Rev.	Date	Drawn	Note	Approved by:	姚利明			
BESTAR HOLDING CO.,LTD						DRG NO: BS/TES01.461F	Page:05 of 08	
www.bestargroups.com wu@be-star.com								

This print and information there in are proprietary to BeStar Holding Co., Ltd. and shall not be used in whole or in part without its written content

BDT3032H12.8-03 LF

5. Reliability test

1. Endurance test
 - Duration 240hrs
 - at square wave, duty cycle: 50% asymmetric, $U_n=7V_{op}$ $f=2048Hz$
 - Temperature cycle $-40...+85^{\circ}C$ with cycle duration 4h; 10s on/off
2. High temperature durability acc. to IEC 60068 part2-2
 - Temperature $+85^{\circ}C$
 - Duration 1000h
3. Low temperature durability acc. to IEC 60068 part 2-1
 - Temperature $-40^{\circ}C$
 - Duration 500h
4. Humidity durability acc. to IEC 60068 part2-3
 - Temperature $40^{\circ}C$
 - Rel. humidity 93%RH
 - Duration 56days
5. Temperature cycle durability acc. to IEC60068 part2-14
 - Low Temperature $-40^{\circ}C$
 - Upper Temperature $+85^{\circ}C$
 - Transfer time from lower to upper temperature $<10s$
 - Number of cycles 100cycles
6. Shock test acc. to IEC 60068 part2-27
 - 100g for each free mutually perpendicular directions to each of 3times by sine-wave
7. Vibration test acc. to IEC 60068 part 2 -6
 - sine-wave excitation; 8...300Hz, 2g, 1 octave/min; test time 16h each axis
 - Additional requirements:
 - Test of solderability and resistance to soldering heat acc. to VDON4.3643.001
 - X-ray solderpoint inspection according to VDON 4.4814.001
 - Washability: not washable
 - Cadmium prohibited as per DIN 5.5000.1
8. Wave soldering

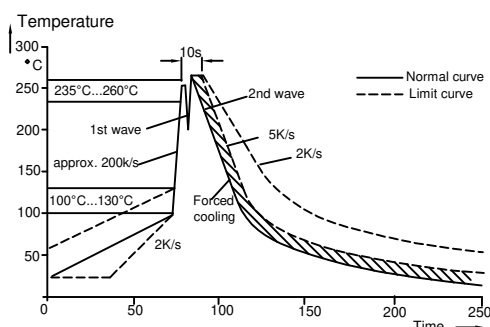

This print and information there in are proprietary to BeStar Holding Co., Ltd. and shall not be used in whole or in part without its written content

				Date:	16/ 11/29	BDT3032H12.8-03 LF
F	16/ 11/29	邱蒙		Drawn by:	邱蒙	
A	07/08/09	莫丽丽		Checked by:	魏奉玲	Speaker
Rev.	Date	Drawn	Note	Approved by:	姚利明	
BESTAR HOLDING CO.,LTD						DRG NO: BS/TES01.461F
www.bestargroups.com wu@be-star.com						

BDT3032H12.8-03 LF

6. Packing

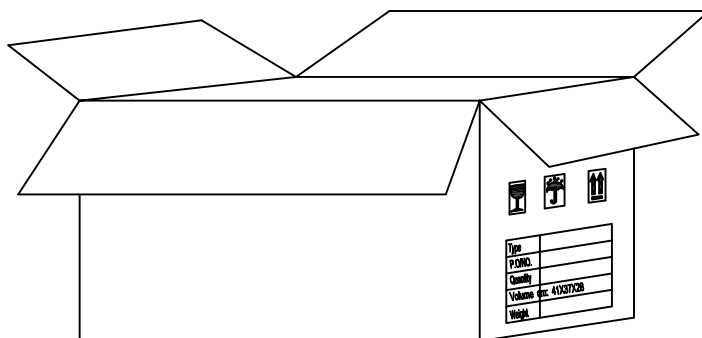
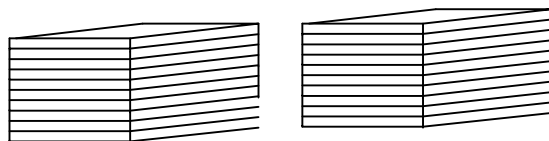

Remark :
 40pcs per tray
 20 trays per carton
 720pcs per carton
 Carton size : 41x37x27cm

This print and information there in are proprietary to BeStar Holding Co., Ltd. and shall not be used in whole or in part without its written content

				Date:	16/ 11/29	BDT3032H12.8-03 LF	
F	16/ 11/29	邱蒙		Drawn by:	邱蒙		
A	A	07/08/09	莫丽丽	Checked by:	魏奉玲	Speaker	
Rev.	Date	Drawn	Note	Approved by:	姚利明		
BESTAR HOLDING CO.,LTD						DRG NO: BS/TES01.461F	Page:07 of 08
www.bestargroups.com wu@be-star.com							

BDT3032H12.8-03 LF

7. History change record

version No.	Change Items		Date	Drawn	Approved
	Before	After			
A			07/08/09	莫丽丽	张秀琴
B		change housing	11/03/01	莫丽丽	张秀琴
		change PCB			
		mould "+" and "-" on the housing			
	SH3032P-03A	SH3032P-03B			
C		Adding Sn after spot-welding	11/12/23	莫丽丽	张秀琴
		Using hot air bonding of wire			
D	The foam box packaging, every box 50 pcs, every batch 2000 pcs,the QR code size is 50*30mm, just use in JCI customer	The skin packing ,every box 40 pcs, every batch 2240 pcs, the QR code size is 25*20 mm, just use in JCI customer	14/ 07/24	李楠	印苏徽
E	skin packing,every plastic box use a cardboard , only use in JCI customer	skin packing,every plastic box use a plastic layer . only use in Visteon customer	16.08.29	邱蒙	姚利明
F	30 trays per carton , 1120PCS per carton Carton size : 41x37x39cm	20 trays per carton 720pcs per carton Carton size : 41x37x27cm, the weight of per carton within 12Kg	16.11.29	邱蒙	姚利明

This print and information there in are proprietary to BeStar Holding Co., Ltd. and shall not be used in whole or in part without its written content

				Date:	16/ 11/29	BDT3032H12.8-03 LF
F	16/ 11/29	邱蒙		Drawn by:	邱蒙	
A	A	07/08/09	莫丽丽	Checked by:	魏奉玲	Speaker
Rev.	Date	Drawn	Note	Approved by:	姚利明	
BESTAR HOLDING CO.,LTD						DRG NO: BS/TES01.461F
www.bestargroups.com wu@be-star.com						Page:08 of 08