

LOC		DIST		REVISIONS			
P	LTR	DESCRIPTION	DATE	DN	APVD		
C		REVISED PER ECR-15-010337	23JUL2015	RK	SC		

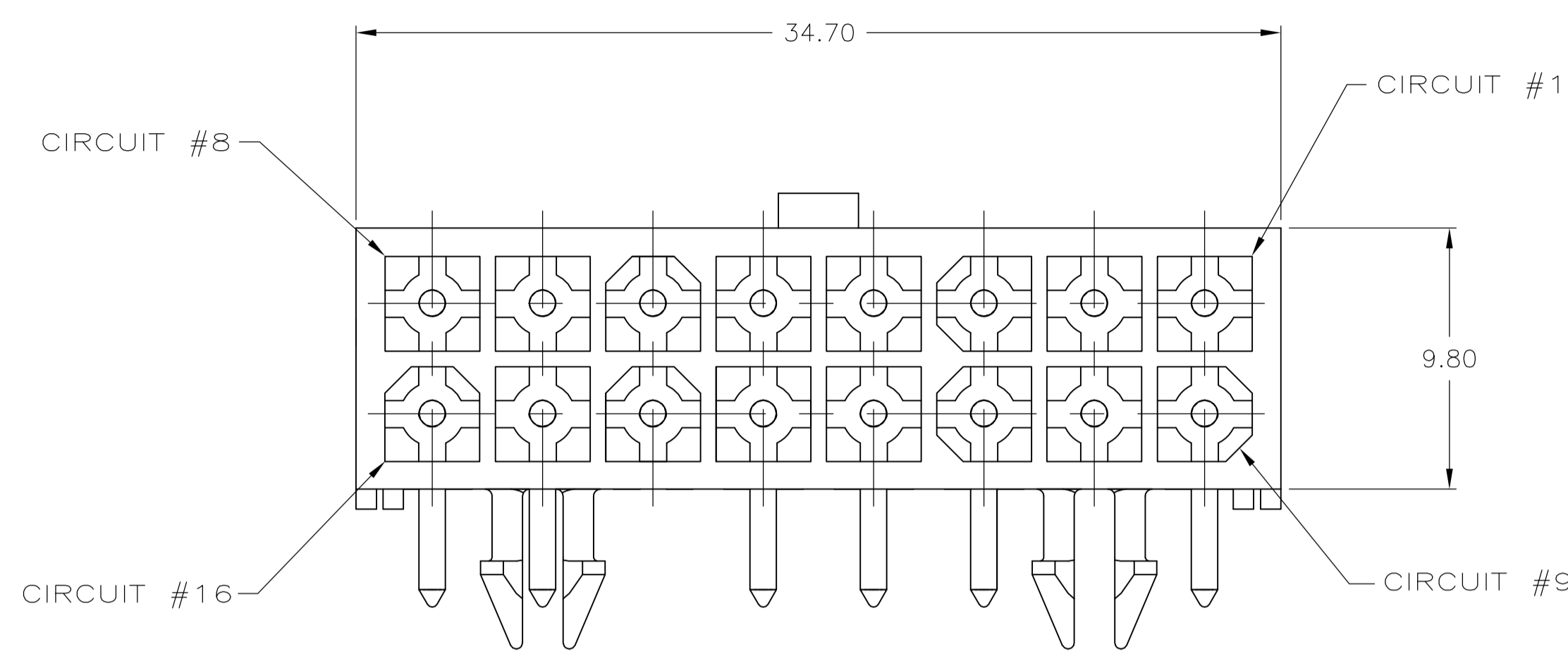

- 1 PINS TO COMPLY WITH AMP SOLDERABILITY SPEC 109-11-3.
- 2 MATES WITH PLUG P/N 770583-1.
- 3 COORDINATE DIMENSION APPLIES FROM CENTER OF ACTUAL FEATURE.
- 4 RECOMMENDED FOR EDGE MOUNTING.
- 5 0.00076 MIN GOLD PLATE IN THE LOCALIZED GOLD PLATE AREA, 0.00381 MIN MATTE TIN IN THE LOCALIZED TIN PLATE AREA, BOTH OVER 0.00127 MIN NICKEL.

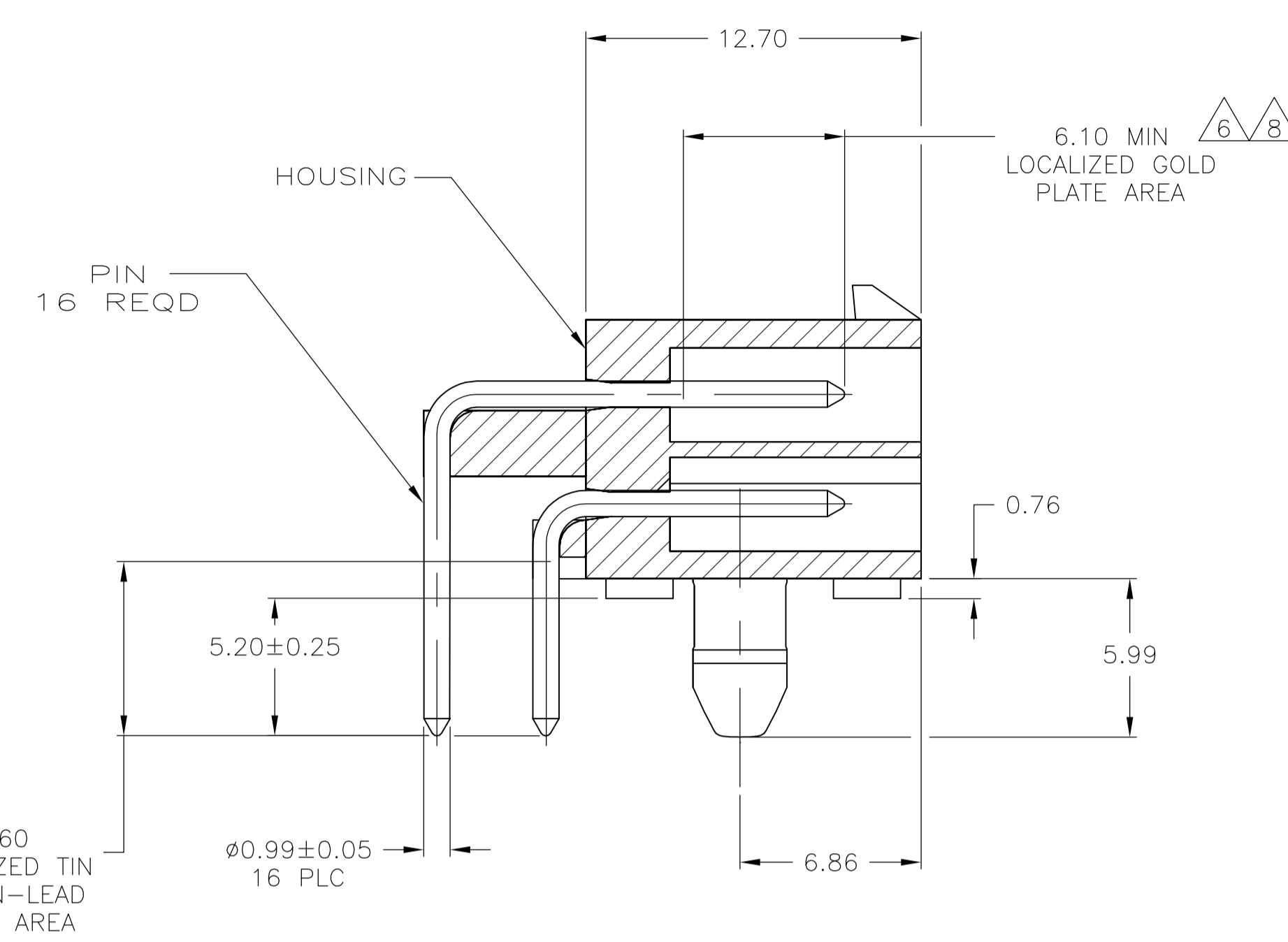
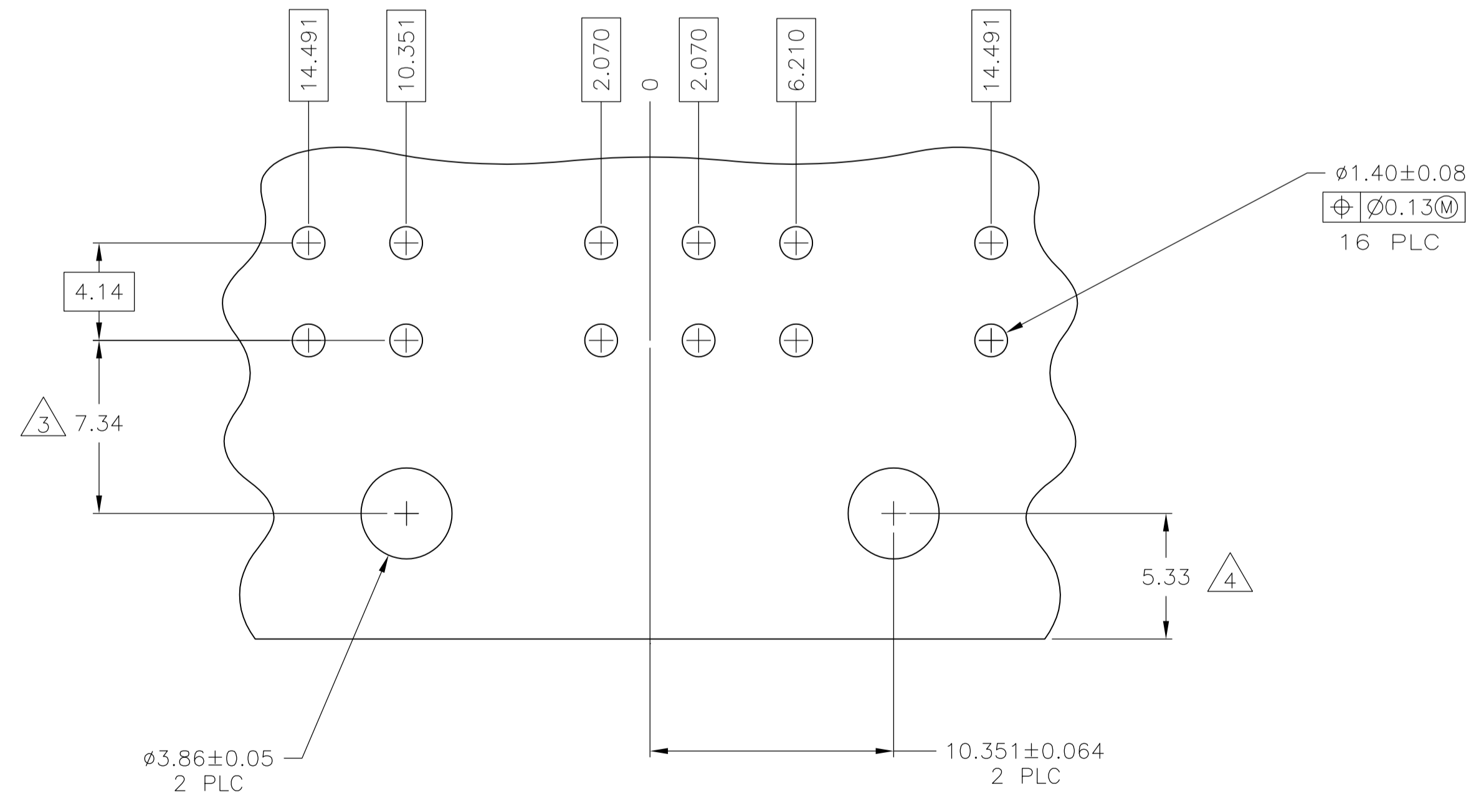

RECOMMENDED MOUNTING HOLE PATTERN FOR 1.57 THICK P.C. BOARD

MM	IN	MM	IN
3.68	.145	34.70	1.366
2.070	.0815	14.491	.5705
1.57	.062	12.70	.500
1.40	.055	10.351	.4075
1.00	.039	9.80	.386
0.76	.030	7.34	.289
0.25	.010	6.86	.270
0.13	.005	6.210	.2445
0.08	.003	6.10	.240
0.064	.0025	5.99	.236
0.05	.002	5.33	.210
0.00381	0.000150	5.08	.200
0.00127	0.000050	4.14	.163
0.00076	0.000030	3.86	.152
MM	IN	MM	IN

CONVERSION TABLE

THIS DRAWING IS A CONTROLLED DOCUMENT.		DIN K. WHITAKER 11APR2007		NYLON, UL94V-0		WHITE		1586821-2	
DIMENSIONS: mm		TOLERANCES UNLESS OTHERWISE SPECIFIED:		MATERIAL FINISH		MATERIAL COLOR		PART NO.	
0 PLC ± -		1 PLC ± -		PIN		HOUSING		CUSTOMER DRAWING	
1 PLC ± -		2 PLC ± -		BRASS		NYLON, UL94V-0		SCALE 5:1	
2 PLC ± -		3 PLC ± 0.13		FINISH		WHITE		SHEET 1 OF 1	
3 PLC ± -		4 PLC ± -		MATERIAL		NYLON, UL94V-0		REV C	
4 PLC ± -		ANGLES ± -		MATERIAL		WHITE			
SEE TABLE		SEE TABLE		MATERIAL		NYLON, UL94V-0			
				MATERIAL		WHITE			
				MATERIAL		NYLON, UL94V-0			
				MATERIAL		WHITE			
				MATERIAL		NYLON, UL94V-0			
				MATERIAL		WHITE			
				MATERIAL		NYLON, UL94V-0			
				MATERIAL		WHITE			
				MATERIAL		NYLON, UL94V-0			
				MATERIAL		WHITE			
				MATERIAL		NYLON, UL94V-0			
				MATERIAL		WHITE			
				MATERIAL		NYLON, UL94V-0			
				MATERIAL		WHITE			
				MATERIAL		NYLON, UL94V-0			
				MATERIAL		WHITE			
				MATERIAL		NYLON, UL94V-0			
				MATERIAL		WHITE			
				MATERIAL		NYLON, UL94V-0			
				MATERIAL		WHITE			
				MATERIAL		NYLON, UL94V-0			
				MATERIAL		WHITE			
				MATERIAL		NYLON, UL94V-0			
				MATERIAL		WHITE			
				MATERIAL		NYLON, UL94V-0			
				MATERIAL		WHITE			
				MATERIAL		NYLON, UL94V-0			
				MATERIAL		WHITE			
				MATERIAL		NYLON, UL94V-0			
				MATERIAL		WHITE			
				MATERIAL		NYLON, UL94V-0			
				MATERIAL		WHITE			
				MATERIAL		NYLON, UL94V-0			
				MATERIAL		WHITE			
				MATERIAL		NYLON, UL94V-0			
				MATERIAL		WHITE			
				MATERIAL		NYLON, UL94V-0			
				MATERIAL		WHITE			
				MATERIAL		NYLON, UL94V-0			
				MATERIAL		WHITE			
				MATERIAL		NYLON, UL94V-0			
				MATERIAL		WHITE			
				MATERIAL		NYLON, UL94V-0			
				MATERIAL		WHITE			
				MATERIAL		NYLON, UL94V-0			
				MATERIAL		WHITE			
				MATERIAL		NYLON, UL94V-0			
				MATERIAL		WHITE			
				MATERIAL		NYLON, UL94V-0			
				MATERIAL		WHITE			
				MATERIAL		NYLON, UL94V-0			
				MATERIAL		WHITE			
				MATERIAL		NYLON, UL94V-0			
				MATERIAL		WHITE			
				MATERIAL		NYLON, UL94V-0			
				MATERIAL		WHITE			
				MATERIAL		NYLON, UL94V-0			
				MATERIAL		WHITE			
				MATERIAL		NYLON, UL94V-0			
				MATERIAL		WHITE			
				MATERIAL		NYLON, UL94V-0			
				MATERIAL		WHITE			
				MATERIAL		NYLON, UL94V-0			
				MATERIAL		WHITE			
				MATERIAL		NYLON, UL94V-0			
				MATERIAL		WHITE			
				MATERIAL		NYLON, UL94V-0			
				MATERIAL		WHITE			
				MATERIAL		NYLON, UL94V-0			
				MATERIAL		WHITE			
				MATERIAL		NYLON, UL94V-0			
				MATERIAL		WHITE			
				MATERIAL		NYLON, UL94V-0			
				MATERIAL		WHITE			
				MATERIAL		NYLON, UL94V-0			
				MATERIAL		WHITE			
				MATERIAL		NYLON, UL94V-0			
				MATERIAL		WHITE			
				MATERIAL		NYLON, UL94V-0			
				MATERIAL		WHITE			
				MATERIAL		NYLON, UL94V-0			
				MATERIAL		WHITE			
				MATERIAL		NYLON, UL94V-0			
				MATERIAL		WHITE			
				MATERIAL		NYLON, UL94V-0			
				MATERIAL		WHITE			
				MATERIAL		NYLON, UL94V-0			
				MATERIAL		WHITE			
				MATERIAL		NYLON, UL94V-0			
				MATERIAL		WHITE			
				MATERIAL		NYLON, UL94V-0			
				MATERIAL		WHITE			
				MATERIAL		NYLON, UL94V-0			
				MATERIAL		WHITE			
				MATERIAL		NYLON, UL94V-0			
				MATERIAL		WHITE			
				MATERIAL		NYLON, UL94V-0			
				MATERIAL		WHITE			
				MATERIAL		NYLON, UL94V-0			
				MATERIAL		WHITE			
				MATERIAL		NYLON, UL94V-0			
				MATERIAL		WHITE			
				MATERIAL		NYLON, UL94V-0			
				MATERIAL		WHITE			
				MATERIAL		NYLON, UL94V-0			
				MATERIAL		WHITE			
				MATERIAL		NYLON, UL94V-0			
				MATERIAL		WHITE			
				MATERIAL		NYLON, UL94V-0			
				MATERIAL		WHITE			
				MATERIAL		NYLON, UL94V-0			
				MATERIAL		WHITE			
				MATERIAL		NYLON, UL94V-0			
				MATERIAL		WHITE			
				MATERIAL		NYLON, UL94V-0			
				MATERIAL		WHITE			
				MATERIAL		NYLON, UL94V-0			
				MATERIAL		WHITE			
				MATERIAL		NYLON, UL94V-0			
				MATERIAL		WHITE			
				MATERIAL		NYLON, UL94V-0			
				MATERIAL		WHITE			
				MATERIAL		NYLON, UL94V-0			
				MATERIAL		WHITE			
				MATERIAL		NYLON, UL94V-0			
				MATERIAL		WHITE			
				MATERIAL		NYLON, UL94V-0			
				MATERIAL		WHITE			
				MATERIAL		NYLON, UL94V-0			
				MATERIAL		WHITE			
				MATERIAL		NYLON, UL94V-0			
				MATERIAL		WHITE			
				MATERIAL		NYLON, UL94V-0			
				MATERIAL		WHITE			
				MATERIAL		NYLON, UL94V-0			
				MATERIAL		WHITE			
				MATERIAL		NYLON, UL94V-0			
				MATERIAL		WHITE			
				MATERIAL		NYLON, UL94V-0			
				MATERIAL		WHITE			
				MATERIAL		NYLON, UL94V-0			
				MATERIAL		WHITE			
				MATERIAL		NYLON, UL94V-0			
				MATERIAL		WHITE			
				MATERIAL		NYLON, UL94V-0			
				MATERIAL		WHITE			
				MATERIAL		NYLON, UL94V-0			
				MATERIAL		WHITE			
				MATERIAL		NYLON, UL94V-0			
				MATERIAL		WHITE			
				MATERIAL		NYLON, UL94V-0			
				MATERIAL		WHITE			
				MATERIAL		NYLON, UL94V-0			
				MATERIAL		WHITE			
				MATERIAL		NYLON, UL94V-0			
				MATERIAL		WHITE			
				MATERIAL		NYLON, UL94V-0			
				MATERIAL		WHITE			
				MATERIAL		NYLON, UL94V-0			
				MATERIAL		WHITE			
				MATERIAL		NYLON, UL94V-0			
				MATERIAL		WHITE			
				MATERIAL		NYLON, UL94V-0			
				MATERIAL		WHITE			
				MATERIAL		NYLON, UL94V-0			
				MATERIAL		WHITE			
				MATERIAL		NYLON, UL94V-0			
				MATERIAL		WHITE			
				MATERIAL		NYLON, UL94V-0			
				MATERIAL		WHITE			
				MATERIAL		NYLON, UL94V-0			
				MATERIAL		WHITE			
				MATERIAL		NYLON, UL94V-0			
				MATERIAL		WHITE			
				MATERIAL		NYLON, UL94V-0			
				MATERIAL		WHITE			
				MATERIAL		NYLON, UL94V-0			
				MATERIAL		WHITE			
				MATERIAL		NYLON, UL94V-0			
				MATERIAL		WHITE			
				MATERIAL					