

## dsPIC33CK64MC105 Motor Control Plug-In Module (PIM) Information Sheet for Internal Op Amp Configuration

The dsPIC33CK64MC105 Internal Op Amp Motor Control PIM (P/N: MA330051-2) is designed to demonstrate the motor control capabilities of the dsPIC33CK64MC105 device using internal op amps available in the device.

The dsPIC33CK64MC105 device is a high-performance, 16-bit Digital Signal Controller (DSC). This Motor Control PIM is designed to take advantage of the high-resolution PWM module, a shared ADC core and operational amplifiers in the device to enable various motor control applications.

The PIM can be used to demonstrate and develop motor control applications by inserting it in the 100-pin PIM interface header provided on the compatible motor control development boards (see [Table 1](#)). The PIM is designed to run a single motor with all the compatible development boards. When operating this PIM on the dsPICDEM™ MCLV-2 Development Board, insert an internal op amp configuration matrix board (see [Figure 2](#)) on the J14 header provided on the board. In the case of dsPICDEM MCHV-2/MCHV-3 Development Boards, insert an internal op amp configuration matrix board onto the J4 header (as shown in [Figure 2](#)) on the board. This PIM can be used on the dsPICDEM MCHV-3 Development Board to implement and demonstrate single-stage boost Power Factor Correction (PFC) control, along with Field-Oriented Control (FOC).

For additional information regarding development boards, refer to the respective user's guide available on the Microchip website ([www.microchip.com](http://www.microchip.com)).

[Table 1](#) provides information on the hardware versions of the motor control boards that are compatible with this PIM. Refer to the specific motor control board user's guide for the hardware version identification information.

**FIGURE 1: dsPIC33CK64MC105 INTERNAL OP AMP MOTOR CONTROL PIM (MA330051-2)**



**FIGURE 2: INTERNAL OP AMP CONFIGURATION BOARD**



# dsPIC33CK64MC105

---

**TABLE 1: HARDWARE COMPATIBILITY**

<b>Development Board</b>	<b>Part Number</b>	<b>Compatible Hardware Version(s)</b>
dsPICDEM™ MCHV Development Board	DM330023	Not Compatible
dsPICDEM MCLV Development Board	DM330021	Not Compatible
Low-Voltage Motor Control Development Bundle	DV330100	Not Compatible
dsPICDEM MCLV-2 Development Board	DM330021-2	All Revisions
dsPICDEM MCHV-2 Development Board	DM330023-2	All Revisions
dsPICDEM MCHV-3 Development Board	DM330023-3	All Revisions

## **WARNING**

**Do not connect non-isolated oscilloscope probes to the test points on the PIM while in use with the dsPICDEM™ MCHV-2 or MCHV-3 Development Board. Failure to heed this warning could result in hardware damage.**

# dsPIC33CK64MC105

Table 2 provides mapping between the 48-pin device pinout and the 100-pin PIM.

**TABLE 2: DEVICE TO PIM MAPPING (SORTED BY DEVICE PIN NUMBER)**

Device Pin #	PIM Pin #	dsPIC33CK64MC105 Device Functional Description	Remarks
1	PIM:94	RP46/PWM1H/RB14	Direct Connection
2	PIM:93	RP47/PWM1L/RB15	Direct Connection
3	PIM:60	RP60/RC12	Direct Connection
4	PIM:01	RP61/RC13	Direct Connection
5	PIM:13	$\overline{\text{MCLR}}$	Direct Connection
6	PIM:47	ANN0/RP77/RD13	Direct Connection
7	PIM:35	AN12/RP48/RC0	Direct Connection
8	—	OA1OUT/AN0/CMP1A/IBIAS0/RA0	Op Amp Output
9	PIM:66	OA1IN-/RA1	Op Amp Input
10	PIM:74	OA1IN+/AN9/RA2	Op Amp Input
11	PIM:25	DACOUT/AN3/CMP1C/RA3	Direct Connection
12	—	OA3OUT/AN4/IBIAS3/RA4	Op Amp Output
13	PIM:30	AVDD	Analog Power (AVDD)
14	PIM:31 <sup>(5)</sup>	AVSS	Analog Ground (AGND)
15	PIM:67	OA3IN-/AN13/CMP1B/ISRC0/RP49/RC1	Op Amp Input
16	PIM:66	OA3IN+/AN14/ISRC1/RP50/RC2	Op Amp Input
17	PIM:19	IBIAS1/RP54/RC6	Direct Connection
18	PIM:02, 16, 37, 46, 62, 86 <sup>(3)</sup>	VDD	Digital Power (DVDD)
19	PIM:15, 36, 45, 65, 75 <sup>(4)</sup>	VSS	Digital Ground (DGND)
20	PIM:32	AN15/IBIAS2/RP51/RC3	Direct Connection
21	PIM:63	OSCI/CLKI/AN5/RP32/RB0	Direct Connection
22	PIM:64	OSCO/CLKO/AN6/RP33/RB1	Direct Connection
23	PIM:48	ISRC3/RP74/RD10	Direct Connection
24	PIM:70	ISRC2/RP55/RC7	Direct Connection
25	—	OA2OUT/AN1/AN7/CMP1D/RP34/INT0/RB2	Op Amp Output
26	PIM:66	PGD2/OA2IN-/AN8/RP35/RB3	Op Amp Input
27	PIM:73	PGC2/OA2IN+/RP36/RB4	Op Amp Input
28	PIM:49	RP56/ASDA1/SCK2/RC8	Direct Connection
29	PIM:68	RP57/ASCL1/SDI2/RC9	Direct Connection
30	PIM:18	RP72/SDO2/PCI19/RD8	Direct Connection
31	PIM:15, 36, 45, 65, 75 <sup>(4)</sup>	VSS	Digital Ground (DGND)
32	PIM:02, 16, 37, 46, 62, 86 <sup>(3)</sup>	VDD	Digital Power (DVDD)
33	PIM:27	PGD3/RP37/RB5	Direct Connection
34	PIM:26	PGC3/RP38/RB6	Direct Connection
35	PIM:24	TDO/AN2/RP39/RB7	Direct Connection
36	PIM:23	PGD1/AN10/RP40/SCL1/RB8	Direct Connection

- Note 1:** The PIM pin is directly connected to the device pin through a 0 Ohm resistor (default), which can be removed if desired.
- Note 2:** The PIM pin can be connected to a device pin through a 0 Ohm resistor, if required. For proper operation, ensure that other 0 Ohm resistors connected to the same device pin are removed.
- Note 3:** Digital Power (DVDD) pins are shorted together on the PIM.
- Note 4:** Digital Ground (DGND) pins are shorted together on the PIM.
- Note 5:** Analog Ground (AGND) connection via PIM:31 is shorted with Digital Ground (DGND) through 0 Ohm resistor, R22, on the PIM.

# dsPIC33CK64MC105

**TABLE 2: DEVICE TO PIM MAPPING (SORTED BY DEVICE PIN NUMBER) (CONTINUED)**

Device Pin #	PIM Pin #	dsPIC33CK64MC105 Device Functional Description	Remarks
37	PIM:79	PGC1/AN11/RP41/SDA1/RB9	Direct Connection
38	PIM:84	RP52/RC4	Direct Connection
39	PIM:80	RP53/RC5	Direct Connection
40	PIM:61 <sup>(2)</sup>	RP58/RC10	Can be connected via 0 Ohm Resistor
	PIM:78 <sup>(1)</sup>		Connected via 0 Ohm Resistor
41	PIM:83	RP59/RC11	Direct Connection
42	PIM:15, 36, 45, 65, 75 <sup>(4)</sup>	Vss	Digital Ground (DGND)
43	PIM:02, 16, 37, 46, 62, 86 <sup>(3)</sup>	VDD	Digital Power (DVDD)
44	PIM:50	RP65/PWM4H/RD1	Direct Connection
45	PIM:03	TMS/RP42/PWM3H/RB10	Direct Connection
46	PIM:100	TCK/RP43/PWM3L/RB11	Direct Connection
47	PIM:99	TDI/RP44/PWM2H/RB12	Direct Connection
48	PIM:98	RP45/PWM2L/RB13	Direct Connection

- Note 1:** The PIM pin is directly connected to the device pin through a 0 Ohm resistor (default), which can be removed if desired.
- 2:** The PIM pin can be connected to a device pin through a 0 Ohm resistor, if required. For proper operation, ensure that other 0 Ohm resistors connected to the same device pin are removed.
- 3:** Digital Power (DVDD) pins are shorted together on the PIM.
- 4:** Digital Ground (DGND) pins are shorted together on the PIM.
- 5:** Analog Ground (AGND) connection via PIM:31 is shorted with Digital Ground (DGND) through 0 Ohm resistor, R22, on the PIM.

# dsPIC33CK64MC105

Table 3 provides mapping between the 100-pin PIM and the 48-pin device pinout.

**TABLE 3: DEVICE TO PIM MAPPING (SORTED BY PIM PIN NUMBER)**

PIM Pin #	Device Pin #	dsPIC33CK64MC105 Device Functional Description	Remarks
PIM:01	4	RP61/RC13	Direct Connection
PIM:02 <sup>(3)</sup>	18, 32, 43	VDD	Digital Power (DVDD)
PIM:03	45	TMS/RP42/PWM3H/RB10	Direct Connection
PIM:04	—	—	Not Connected
PIM:05	—	—	Not Connected
PIM:06	—	—	Not Connected
PIM:07	—	—	Not Connected
PIM:08	—	—	Not Connected
PIM:09	—	—	Not Connected
PIM:10	—	—	Not Connected
PIM:11	—	—	Not Connected
PIM:12	—	—	Not Connected
PIM:13	5	MCLR	Direct Connection
PIM:14	—	—	Not Connected
PIM:15 <sup>(4)</sup>	19, 31, 42	VSS	Digital Ground (DGND)
PIM:16 <sup>(3)</sup>	18, 32, 43	VDD	Digital Power (DVDD)
PIM:17	—	—	Not Connected
PIM:18	30	RP72/SDO2/PCI19/RD8	Direct Connection
PIM:19	17	IBIAS1/RP54/RC6	Direct Connection
PIM:20	—	—	Not Connected
PIM:21	—	—	Not Connected
PIM:22	—	—	Not Connected
PIM:23	36	PGD1/AN10/RP40/SCL1/RB8	Direct Connection
PIM:24	35	TDO/AN2/RP39/RB7	Direct Connection
PIM:25	11	DACOUT/AN3/CMP1C/RA3	Direct Connection
PIM:26	34	PGC3/RP38/RB6	Direct Connection
PIM:27	33	PGD3/RP37/RB5	Direct Connection
PIM:28	—	External 1.65V Reference	External 1.65V Reference
PIM:29	—	—	Not Connected
PIM:30	13	AVDD	Analog Power (AVDD)
PIM:31 <sup>(5)</sup>	14	AVSS	Analog Ground (AGND)
PIM:32	20	AN15/IBIAS2/RP51/RC3	Direct Connection
PIM:33	—	—	Not Connected
PIM:34	—	—	Not Connected
PIM:35	7	AN12/RP48/RC0	Direct Connection
PIM:36 <sup>(4)</sup>	19, 31, 42	VSS	Digital Ground (DGND)
PIM:37 <sup>(3)</sup>	18, 32, 43	VDD	Digital Power (DVDD)
PIM:38	—	—	Not Connected
PIM:39	—	—	Not Connected

- Note 1:** The PIM pin is directly connected to the device pin through a 0 Ohm resistor (default), which can be removed if desired.
- 2:** The PIM pin can be connected to a device pin through a 0 Ohm resistor, if desired. For proper operation, ensure that other 0 Ohm resistors connected to the same device pin are removed.
- 3:** Digital Power (DVDD) pins are shorted together on the PIM.
- 4:** Digital Ground (DGND) pins are shorted together on the PIM.
- 5:** Analog Ground (AGND) connection via PIM:31 is shorted with Digital Ground (DGND) through 0 Ohm resistor, R22, on the PIM.

# dsPIC33CK64MC105

**TABLE 3: DEVICE TO PIM MAPPING (SORTED BY PIM PIN NUMBER) (CONTINUED)**

PIM Pin #	Device Pin #	dsPIC33CK64MC105 Device Functional Description	Remarks
PIM:40	—	—	Not Connected
PIM:41	—	—	Not Connected
PIM:42	—	—	Not Connected
PIM:43	—	—	Not Connected
PIM:44	—	—	Not Connected
PIM:45 <sup>(4)</sup>	19, 31, 42	VSS	Digital Ground (DGND)
PIM:46 <sup>(3)</sup>	18, 32, 43	VDD	Digital Power (DVDD)
PIM:47	6	ANN0/RP77/RD13	Direct Connection
PIM:48	23	ISRC3/RP74/RD10	Direct Connection
PIM:49	28	RP56/ASDA1/SCK2/RC8	Direct Connection
PIM:50	44	RP65/PWM4H/RD1	Direct Connection
PIM:51	—	—	Not Connected
PIM:52	—	—	Not Connected
PIM:53	—	—	Not Connected
PIM:54	—	—	Not Connected
PIM:55	—	—	Not Connected
PIM:56	—	—	Not Connected
PIM:57	—	—	Not Connected
PIM:58	—	—	Not Connected
PIM:59	—	—	Not Connected
PIM:60	3	RP60/RC12	Direct Connection
PIM:61 <sup>(2)</sup>	40	RP58/RC10	Can be connected via 0 Ohm Resistor
PIM:62 <sup>(3)</sup>	18, 32, 43	VDD	Digital Power (DVDD)
PIM:63	21	OSCI/CLKI/AN5/RP32/RB0	Direct Connection
PIM:64	22	OSCO/CLKO/AN6/RP33/RB1	Direct Connection
PIM:65 <sup>(4)</sup>	19, 31, 42	VSS	Digital Ground (DGND)
PIM:66	9	OA1IN-/RA1	Op Amp Input
	16	OA3IN+/AN14/ISRC1/RP50/RC2	Op Amp Input
	26	PGD2/OA2IN-/AN8/RP35/RB3	Op Amp Input
PIM:67	15	OA3IN-/AN13/CMP1B/ISRC0/RP49/RC1	Op Amp Input
PIM:68	29	RP57/ASCL1/SDI2/RC9	Direct Connection
PIM:69	—	—	Not Connected
PIM:70	24	ISRC2/RP55/RC7	Direct Connection
PIM:71	—	—	Not Connected
PIM:72	—	—	Not Connected
PIM:73	27	PGC2/OA2IN+/RP36/RB4	Op Amp Input
PIM:74	10	OA1IN+/AN9/RA2	Op Amp Input
PIM:75 <sup>(4)</sup>	19, 31, 42	VSS	Digital Ground (DGND)
PIM:76	—	—	Not Connected
PIM:77	—	—	Not Connected
PIM:78 <sup>(1)</sup>	40	RP58/RC10	Connected via 0 Ohm Resistor
PIM:79	37	PGC1/AN11/RP41/SDA1/RB9	Direct Connection

- Note 1:** The PIM pin is directly connected to the device pin through a 0 Ohm resistor (default), which can be removed if desired.
- 2:** The PIM pin can be connected to a device pin through a 0 Ohm resistor, if desired. For proper operation, ensure that other 0 Ohm resistors connected to the same device pin are removed.
- 3:** Digital Power (DVDD) pins are shorted together on the PIM.
- 4:** Digital Ground (DGND) pins are shorted together on the PIM.
- 5:** Analog Ground (AGND) connection via PIM:31 is shorted with Digital Ground (DGND) through 0 Ohm resistor, R22, on the PIM.

# dsPIC33CK64MC105

**TABLE 3: DEVICE TO PIM MAPPING (SORTED BY PIM PIN NUMBER) (CONTINUED)**

PIM Pin #	Device Pin #	dsPIC33CK64MC105 Device Functional Description	Remarks
PIM:80	39	RP53/RC5	Direct Connection
PIM:81	—	—	Not Connected
PIM:82	—	—	Not Connected
PIM:83	41	RP59/RC11	Direct Connection
PIM:84	38	RP52/RC4	Direct Connection
PIM:85	—	—	Not Connected
PIM:86 <sup>(3)</sup>	18, 32, 43	VDD	Digital Power (DVDD)
PIM:87	—	—	Not Connected
PIM:88	—	—	Not Connected
PIM:89	—	—	Not Connected
PIM:90	—	—	Not Connected
PIM:91	—	—	Not Connected
PIM:92	—	—	Not Connected
PIM:93	2	RP47/PWM1L/RB15	Direct Connection
PIM:94	1	RP46/PWM1H/RB14	Direct Connection
PIM:95	—	—	Not Connected
PIM:96	—	—	Not Connected
PIM:97	—	—	Not Connected
PIM:98	48	RP45/PWM2L/RB13	Direct Connection
PIM:99	47	TDI/RP44/PWM2H/RB12	Direct Connection
PIM:100	46	TCK/RP43/PWM3L/RB11	Direct Connection

- Note 1:** The PIM pin is directly connected to the device pin through a 0 Ohm resistor (default), which can be removed if desired.
- Note 2:** The PIM pin can be connected to a device pin through a 0 Ohm resistor, if desired. For proper operation, ensure that other 0 Ohm resistors connected to the same device pin are removed.
- Note 3:** Digital Power (DVDD) pins are shorted together on the PIM.
- Note 4:** Digital Ground (DGND) pins are shorted together on the PIM.
- Note 5:** Analog Ground (AGND) connection via PIM:31 is shorted with Digital Ground (DGND) through 0 Ohm resistor, R22, on the PIM.

# dsPIC33CK64MC105

Table 4 classifies the passive components according to their functionality and quotes the design equations applicable in each case.

**TABLE 4: ANALOG FUNCTIONALITY LISTING**

Op Amp #	Analog Function	Passive Components	Design Equations
1	Low-Pass Filter	R15, R16, R17, R18, C12, C13, C14	$R15 = R16 = R17 = R18 = R$ $C12 = C14 = C$
	Reference Voltage Bias	R19, R20	$R19 = R20$
	Differential Amplifier Input	R15, R16, R17, R18	$Common-mode f_{-3dB} \cong \frac{1}{2\pi RC}$
	Differential Amplifier Feedback	R20	$Differential-mode f_{-3dB} \cong \frac{1}{2\pi(2R)\left(\frac{C}{2} + C13\right)}$  $Differential Amplifier Gain = \frac{R20}{2R}$
2	Low-Pass Filter	R1, R2, R3, R4, C6, C7, C8	$R1 = R2 = R3 = R4 = R$ $C6 = C8 = C$
	Reference Voltage Bias	R5, R6	$R5 = R6$
	Differential Amplifier Input	R1, R2, R3, R4	$Common-mode f_{-3dB} \cong \frac{1}{2\pi RC}$
	Differential Amplifier Feedback	R6	$Differential-mode f_{-3dB} \cong \frac{1}{2\pi(2R)\left(\frac{C}{2} + C7\right)}$  $Differential Amplifier Gain = \frac{R6}{2R}$
3	Low-Pass Filter	R8, R9, R10, R11, C9, C10, C11	$R8 = R9 = R10 = R11 = R$ $C9 = C11 = C$
	Reference Voltage Bias	R12, R13	$R12 = R13$
	Differential Amplifier Input	R8, R9, R10, R11	$Common-mode f_{-3dB} \cong \frac{1}{2\pi RC}$
	Differential Amplifier Feedback	R13	$Differential-mode f_{-3dB} \cong \frac{1}{2\pi(2R)\left(\frac{C}{2} + C10\right)}$  $Differential Amplifier Gain = \frac{R13}{2R}$



**FIGURE 3: INTERNAL OP AMP CONFIGURATION**

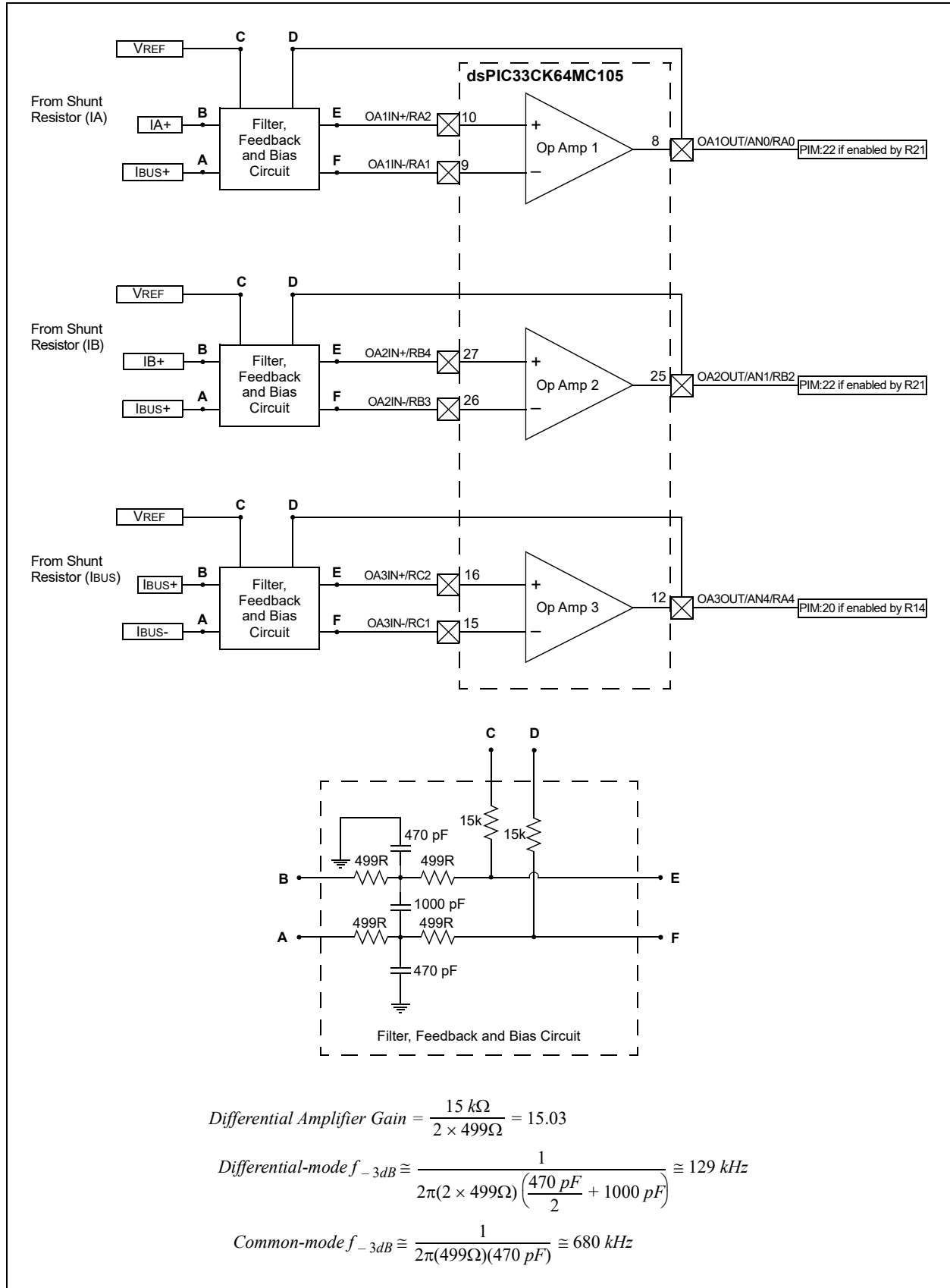

# dsPIC33CK64MC105 Motor Control Plug-In Module (PIM) for Internal Op Amp Configuration

## Schematic Revision 2.0

### dsPIC33CK64MC105 Internal Op Amp Motor Control PIM

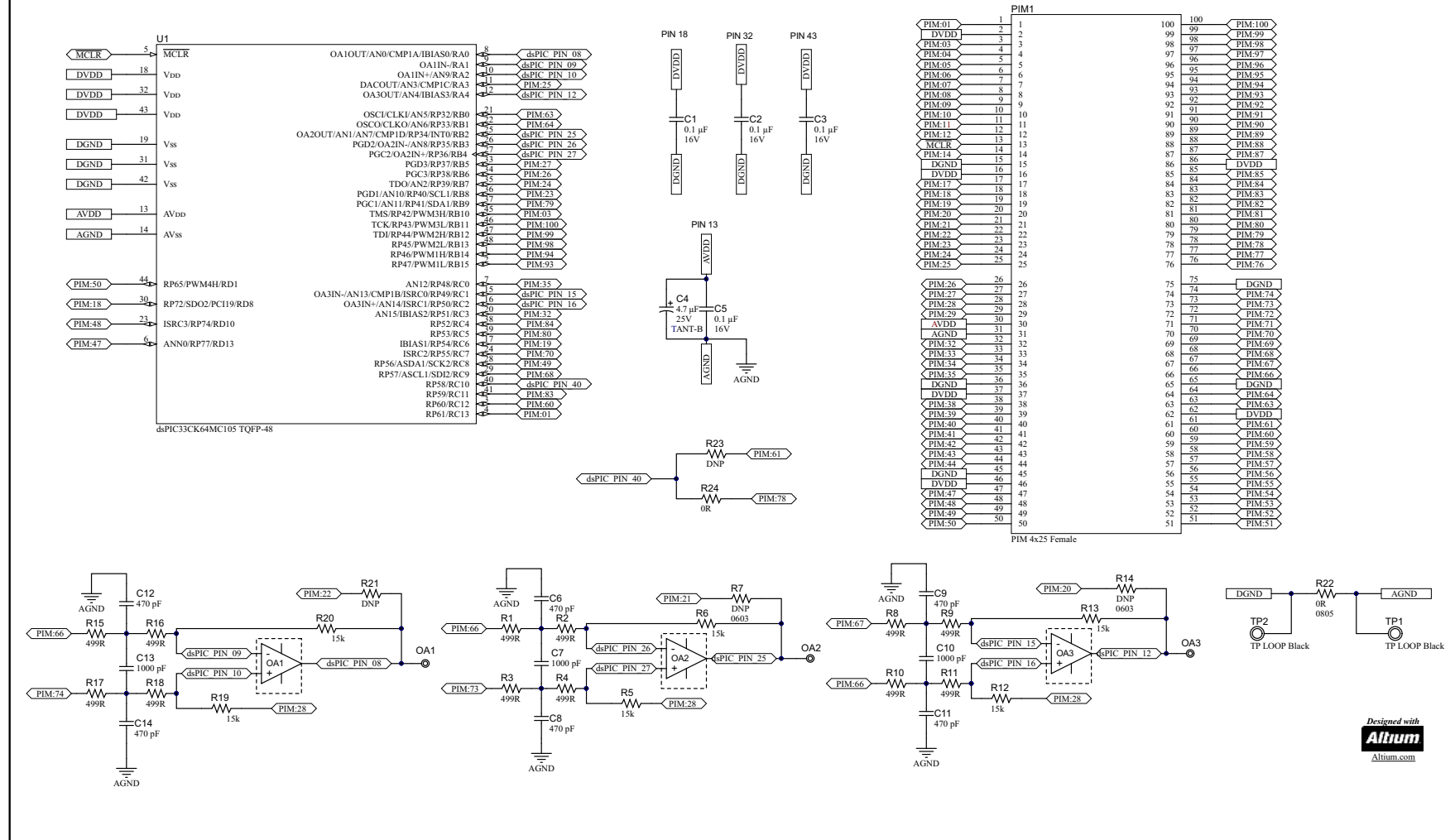

---

**Note the following details of the code protection feature on Microchip devices:**

- Microchip products meet the specifications contained in their particular Microchip Data Sheet.
- Microchip believes that its family of products is secure when used in the intended manner and under normal conditions.
- There are dishonest and possibly illegal methods being used in attempts to breach the code protection features of the Microchip devices. We believe that these methods require using the Microchip products in a manner outside the operating specifications contained in Microchip's Data Sheets. Attempts to breach these code protection features, most likely, cannot be accomplished without violating Microchip's intellectual property rights.
- Microchip is willing to work with any customer who is concerned about the integrity of its code.
- Neither Microchip nor any other semiconductor manufacturer can guarantee the security of its code. Code protection does not mean that we are guaranteeing the product is "unbreakable." Code protection is constantly evolving. We at Microchip are committed to continuously improving the code protection features of our products. Attempts to break Microchip's code protection feature may be a violation of the Digital Millennium Copyright Act. If such acts allow unauthorized access to your software or other copyrighted work, you may have a right to sue for relief under that Act.

---

Information contained in this publication is provided for the sole purpose of designing with and using Microchip products. Information regarding device applications and the like is provided only for your convenience and may be superseded by updates. It is your responsibility to ensure that your application meets with your specifications.

THIS INFORMATION IS PROVIDED BY MICROCHIP "AS IS". MICROCHIP MAKES NO REPRESENTATIONS OR WARRANTIES OF ANY KIND WHETHER EXPRESS OR IMPLIED, WRITTEN OR ORAL, STATUTORY OR OTHERWISE, RELATED TO THE INFORMATION INCLUDING BUT NOT LIMITED TO ANY IMPLIED WARRANTIES OF NON-INFRINGEMENT, MERCHANTABILITY, AND FITNESS FOR A PARTICULAR PURPOSE OR WARRANTIES RELATED TO ITS CONDITION, QUALITY, OR PERFORMANCE.

IN NO EVENT WILL MICROCHIP BE LIABLE FOR ANY INDIRECT, SPECIAL, PUNITIVE, INCIDENTAL OR CONSEQUENTIAL LOSS, DAMAGE, COST OR EXPENSE OF ANY KIND WHATSOEVER RELATED TO THE INFORMATION OR ITS USE, HOWEVER CAUSED, EVEN IF MICROCHIP HAS BEEN ADVISED OF THE POSSIBILITY OR THE DAMAGES ARE FORESEEABLE. TO THE FULLEST EXTENT ALLOWED BY LAW, MICROCHIP'S TOTAL LIABILITY ON ALL CLAIMS IN ANY WAY RELATED TO THE INFORMATION OR ITS USE WILL NOT EXCEED THE AMOUNT OF FEES, IF ANY, THAT YOU HAVE PAID DIRECTLY TO MICROCHIP FOR THE INFORMATION. Use of Microchip devices in life support and/or safety applications is entirely at the buyer's risk, and the buyer agrees to defend, indemnify and hold harmless Microchip from any and all damages, claims, suits, or expenses resulting from such use. No licenses are conveyed, implicitly or otherwise, under any Microchip intellectual property rights unless otherwise stated.

For information regarding Microchip's Quality Management Systems, please visit [www.microchip.com/quality](http://www.microchip.com/quality).

**Trademarks**

The Microchip name and logo, the Microchip logo, Adaptec, AnyRate, AVR, AVR logo, AVR Freaks, BesTime, BitCloud, chipKIT, chipKIT logo, CryptoMemory, CryptoRF, dsPIC, FlashFlex, flexPWR, HELDO, IGLoo, JukeBlox, KeeLoq, Klear, LANCheck, LinkMD, maXStylus, maXTouch, MediaLB, megaAVR, Microsemi, Microsemi logo, MOST, MOST logo, MPLAB, OptoLyzer, PackeTime, PIC, picoPower, PICSTART, PIC32 logo, PolarFire, Prochip Designer, QTouch, SAM-BA, SenGenuity, SpyNIC, SST, SST Logo, SuperFlash, Symmetricom, SyncServer, Tachyon, TempTracker, TimeSource, tinyAVR, UNI/O, Vectron, and XMEGA are registered trademarks of Microchip Technology Incorporated in the U.S.A. and other countries.

APT, ClockWorks, The Embedded Control Solutions Company, EtherSynch, FlashTec, Hyper Speed Control, HyperLight Load, IntelliMOS, Libero, motorBench, mTouch, Powermite 3, Precision Edge, ProASIC, ProASIC Plus, ProASIC Plus logo, Quiet-Wire, SmartFusion, SyncWorld, Temux, TimeCesium, TimeHub, TimePictra, TimeProvider, Vite, WinPath, and ZL are registered trademarks of Microchip Technology Incorporated in the U.S.A.

Adjacent Key Suppression, AKS, Analog-for-the-Digital Age, Any Capacitor, AnyIn, AnyOut, BlueSky, BodyCom, CodeGuard, CryptoAuthentication, CryptoAutomotive, CryptoCompanion, CryptoController, dsPICDEM, dsPICDEM.net, Dynamic Average Matching, DAM, ECAN, EtherGREEN, In-Circuit Serial Programming, ICSP, INICnet, Inter-Chip Connectivity, JitterBlocker, KlearNet, KlearNet logo, memBrain, Mindi, MiWi, MPASM, MPF, MPLAB Certified logo, MPLIB, MPLINK, MultiTRAK, NetDetach, Omniscient Code Generation, PICDEM, PICDEM.net, PICkit, PICtail, PowerSmart, PureSilicon, QMatrix, REAL ICE, Ripple Blocker, SAM-ICE, Serial Quad I/O, SMART-I.S., SQR, SuperSwitcher, SuperSwitcher II, Total Endurance, TSHARC, USBCheck, VariSense, ViewSpan, WiperLock, Wireless DNA, and ZENA are trademarks of Microchip Technology Incorporated in the U.S.A. and other countries.

SQTP is a service mark of Microchip Technology Incorporated in the U.S.A.

The Adaptec logo, Frequency on Demand, Silicon Storage Technology, and Symmcom are registered trademarks of Microchip Technology Inc. in other countries.

GestIC is a registered trademark of Microchip Technology Germany II GmbH & Co. KG, a subsidiary of Microchip Technology Inc., in other countries.

All other trademarks mentioned herein are property of their respective companies.

© 2019-2020, Microchip Technology Incorporated, All Rights Reserved.

ISBN: 978-1-5224-6602-4



# MICROCHIP

## Worldwide Sales and Service

### AMERICAS

**Corporate Office**  
2355 West Chandler Blvd.  
Chandler, AZ 85224-6199  
Tel: 480-792-7200  
Fax: 480-792-7277  
Technical Support:  
<http://www.microchip.com/support>  
Web Address:  
[www.microchip.com](http://www.microchip.com)

#### Atlanta

Duluth, GA  
Tel: 678-957-9614  
Fax: 678-957-1455

#### Austin, TX

Tel: 512-257-3370

#### Boston

Westborough, MA  
Tel: 774-760-0087  
Fax: 774-760-0088

#### Chicago

Itasca, IL  
Tel: 630-285-0071  
Fax: 630-285-0075

#### Dallas

Addison, TX  
Tel: 972-818-7423  
Fax: 972-818-2924

#### Detroit

Novi, MI  
Tel: 248-848-4000

#### Houston, TX

Tel: 281-894-5983

#### Indianapolis

Noblesville, IN  
Tel: 317-773-8323  
Fax: 317-773-5453  
Tel: 317-536-2380

#### Los Angeles

Mission Viejo, CA  
Tel: 949-462-9523  
Fax: 949-462-9608  
Tel: 951-273-7800

#### Raleigh, NC

Tel: 919-844-7510

#### New York, NY

Tel: 631-435-6000

#### San Jose, CA

Tel: 408-735-9110  
Tel: 408-436-4270

#### Canada - Toronto

Tel: 905-695-1980  
Fax: 905-695-2078

### ASIA/PACIFIC

**Australia - Sydney**  
Tel: 61-2-9868-6733

**China - Beijing**  
Tel: 86-10-8569-7000

**China - Chengdu**  
Tel: 86-28-8665-5511

**China - Chongqing**  
Tel: 86-23-8980-9588

**China - Dongguan**  
Tel: 86-769-8702-9880

**China - Guangzhou**  
Tel: 86-20-8755-8029

**China - Hangzhou**  
Tel: 86-571-8792-8115

**China - Hong Kong SAR**  
Tel: 852-2943-5100

**China - Nanjing**  
Tel: 86-25-8473-2460

**China - Qingdao**  
Tel: 86-532-8502-7355

**China - Shanghai**  
Tel: 86-21-3326-8000

**China - Shenyang**  
Tel: 86-24-2334-2829

**China - Shenzhen**  
Tel: 86-755-8864-2200

**China - Suzhou**  
Tel: 86-186-6233-1526

**China - Wuhan**  
Tel: 86-27-5980-5300

**China - Xian**  
Tel: 86-29-8833-7252

**China - Xiamen**  
Tel: 86-592-2388138

**China - Zhuhai**  
Tel: 86-756-3210040

### ASIA/PACIFIC

**India - Bangalore**  
Tel: 91-80-3090-4444

**India - New Delhi**  
Tel: 91-11-4160-8631

**India - Pune**  
Tel: 91-20-4121-0141

**Japan - Osaka**  
Tel: 81-6-6152-7160

**Japan - Tokyo**  
Tel: 81-3-6880-3770

**Korea - Daegu**  
Tel: 82-53-744-4301

**Korea - Seoul**  
Tel: 82-2-554-7200

**Malaysia - Kuala Lumpur**  
Tel: 60-3-7651-7906

**Malaysia - Penang**  
Tel: 60-4-227-8870

**Philippines - Manila**  
Tel: 63-2-634-9065

**Singapore**  
Tel: 65-6334-8870

**Taiwan - Hsin Chu**  
Tel: 886-3-577-8366

**Taiwan - Kaohsiung**  
Tel: 886-7-213-7830

**Taiwan - Taipei**  
Tel: 886-2-2508-8600

**Thailand - Bangkok**  
Tel: 66-2-694-1351

**Vietnam - Ho Chi Minh**  
Tel: 84-28-5448-2100

### EUROPE

**Austria - Wels**  
Tel: 43-7242-2244-39  
Fax: 43-7242-2244-393

**Denmark - Copenhagen**  
Tel: 45-4485-5910  
Fax: 45-4485-2829

**Finland - Espoo**  
Tel: 358-9-4520-820

**France - Paris**  
Tel: 33-1-69-53-63-20  
Fax: 33-1-69-30-90-79

**Germany - Garching**  
Tel: 49-8931-9700

**Germany - Haan**  
Tel: 49-2129-3766400

**Germany - Heilbronn**  
Tel: 49-7131-72400

**Germany - Karlsruhe**  
Tel: 49-721-625370

**Germany - Munich**  
Tel: 49-89-627-144-0  
Fax: 49-89-627-144-44

**Germany - Rosenheim**  
Tel: 49-8031-354-560

**Israel - Ra'anana**  
Tel: 972-9-744-7705

**Italy - Milan**  
Tel: 39-0331-742611  
Fax: 39-0331-466781

**Italy - Padova**  
Tel: 39-049-7625286

**Netherlands - Drunen**  
Tel: 31-416-690399  
Fax: 31-416-690340

**Norway - Trondheim**  
Tel: 47-7288-4388

**Poland - Warsaw**  
Tel: 48-22-3325737

**Romania - Bucharest**  
Tel: 40-21-407-87-50

**Spain - Madrid**  
Tel: 34-91-708-08-90  
Fax: 34-91-708-08-91

**Sweden - Gothenberg**  
Tel: 46-31-704-60-40

**Sweden - Stockholm**  
Tel: 46-8-5090-4654

**UK - Wokingham**  
Tel: 44-118-921-5800  
Fax: 44-118-921-5820