

THIS DRAWING IS UNPUBLISHED. RELEASED FOR PUBLICATION
 © COPYRIGHT BY TYCO ELECTRONICS CORPORATION. ALL RIGHTS RESERVED.

LOC		DIST		REVISIONS			
P	LTR	DESCRIPTION	DATE	DWN	APVD		
	T	UPDATE PER ECO-06-001864	25 JAN 06	MJS	MKS		

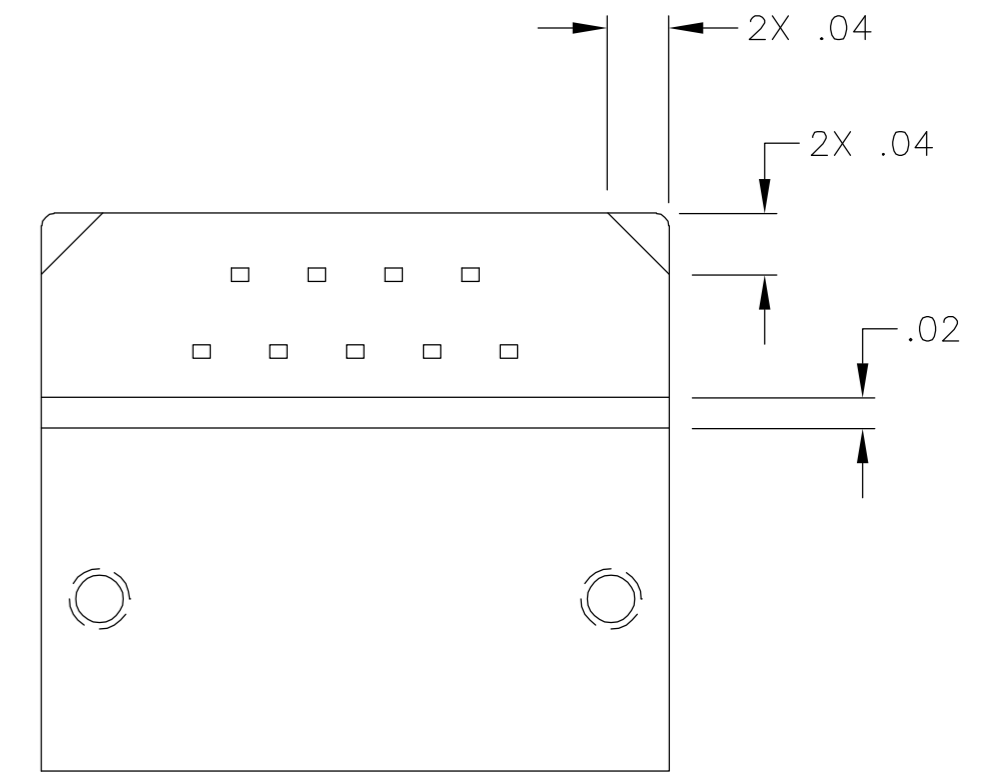
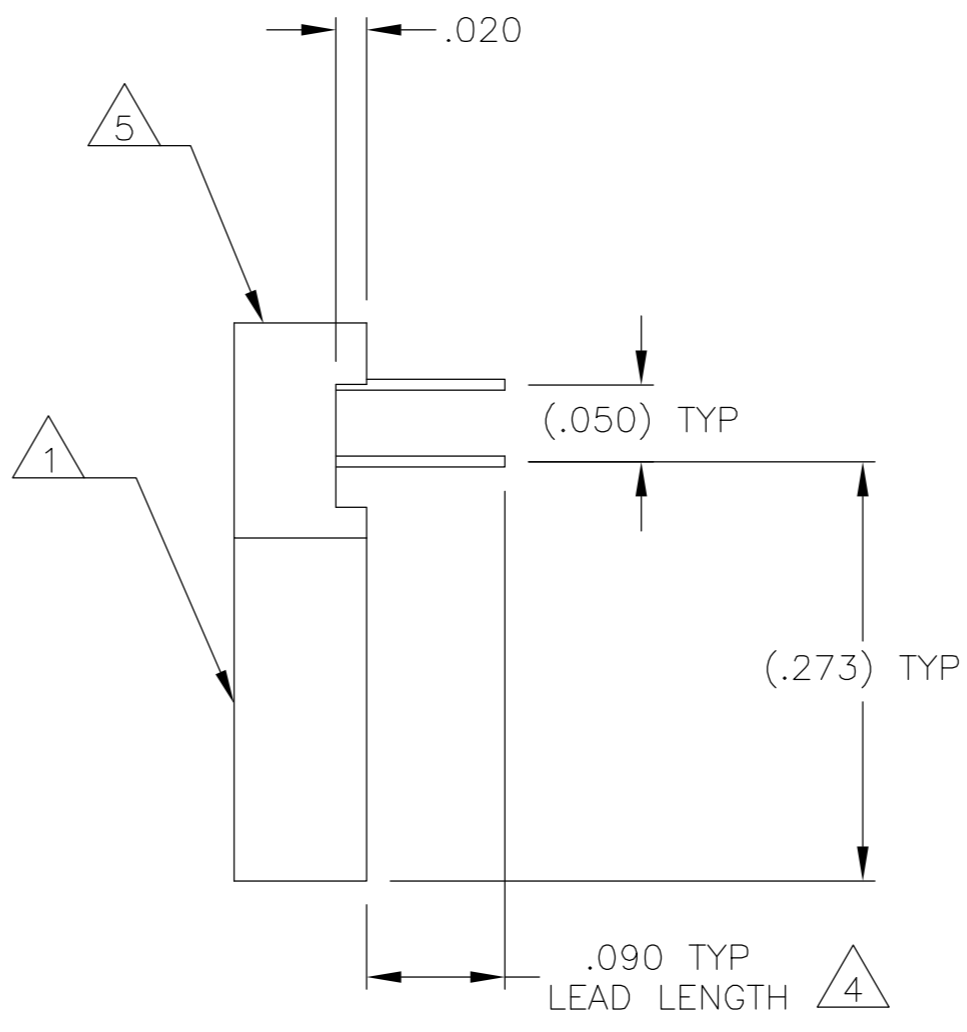
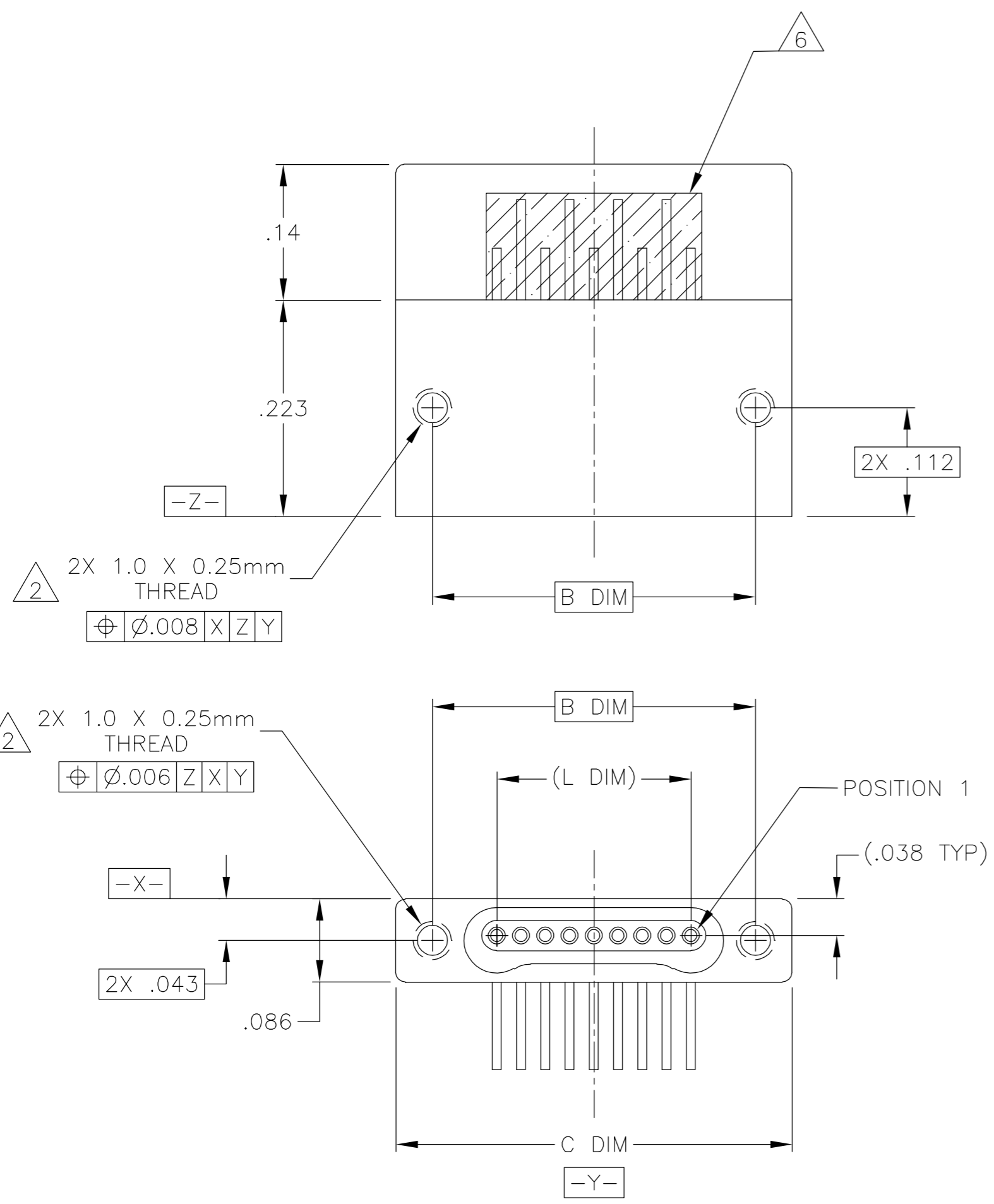

SIZE	B DIM	C DIM ±.0050	(L DIM)
05	.233	.3085	(.100)
09	.333	.4085	(.200)
15	.483	.5585	(.350)
25	.733	.8085	(.600)
37	1.033	1.1085	(.900)
51	1.383	1.4585	(1.250)

1. SHELL OPTIONS (TO BE SPECIFIED IN NANONICS PART NUMBER):
 METAL: 6061-T6 ALUMINUM, ELECTROLESS NICKEL PLATED PER SAE-AMS-C-26074 (STANDARD) OR GOLD PLATED PER ASTM B488
 303 STAINLESS STEEL, PASSIVATED PER SAE-AMS-2700.
 INSULATOR MATERIAL FOR ALL METAL SHELLS IS LIQUID CRYSTAL POLYMER (LCP) PER MIL-M-24519 OR PER ASTM D5138
 PLASTIC: LIQUID CRYSTAL POLYMER (LCP) PER MIL-M-24519 OR PER ASTM D5138
2. STANDARD 1.0 X 0.25mm JACKSCREW AND MOUNTING THREADS ARE SHOWN FOR REFERENCE ONLY AND MUST BE SPECIFIED IN THE NANONICS PART NUMBER WHEN REQUIRED. 1.2 X 0.25mm THREADS ALSO AVAILABLE.
3. MOUNTING HARDWARE IS AVAILABLE WITH THIS CONFIGURATION (NOT SHOWN). HARDWARE MUST BE SPECIFIED IN THE NANONICS PART NUMBER. CONSULT TYCO ELECTRONICS FOR DETAILS.
4. LEADS ARE HH BRASS, TIN LEAD PLATED 60/40 COMPOSITION PER SAE-AMS-P-81728
5. LEAD ORGANIZER MATERIAL IS LIQUID CRYSTAL POLYMER PER ASTM D5138.
6. THROUGH HOLE LEADS ARE EPOXY ENCAPSULATED WITHIN THE LEAD ORGANIZER.
7. TERMINATION CODE: M6
8. THIS DRAWING PREVIOUSLY IDENTIFIED AS NANONICS N10138/150

THIS DRAWING IS A CONTROLLED DOCUMENT.		DWN D. RYAN 06-22-00	Tyco Electronics Corporation Harrisburg, PA 17105	
DIMENSIONS: INCHES		CHK M. STORRY 06-22-00		
TOLERANCES UNLESS OTHERWISE SPECIFIED:		APVD -	NAME	
0 PLC ± - 1 PLC ± - 2 PLC ± .010 3 PLC ± .005 4 PLC ± - ANGLES ± 1° FINISH SEE NOTES		PRODUCT SPEC -	RECEPTACLE ASSEMBLY, HORIZONTAL MOUNT, THROUGH HOLE, 1 ROW TO 2 ROW, .050 SPACING, PLASTIC OR METAL	
MATERIAL SEE NOTES		APPLICATION SPEC -	SIZE A2	CAGE CODE OPJN9
		WEIGHT -	DRAWING NO C=1589469	RESTRICTED TO -
		CUSTOMER DRAWING	SCALE 8:1	SHEET 1 of 2
			REV T	

THIS DRAWING IS UNPUBLISHED. RELEASED FOR PUBLICATION
 © COPYRIGHT BY TYCO ELECTRONICS CORPORATION. ALL RIGHTS RESERVED.

LOC		DIST		REVISIONS			
P	LTR	DESCRIPTION	DATE	DWN	APVD		
-	-	SEE SHEET 1	-	-	-		

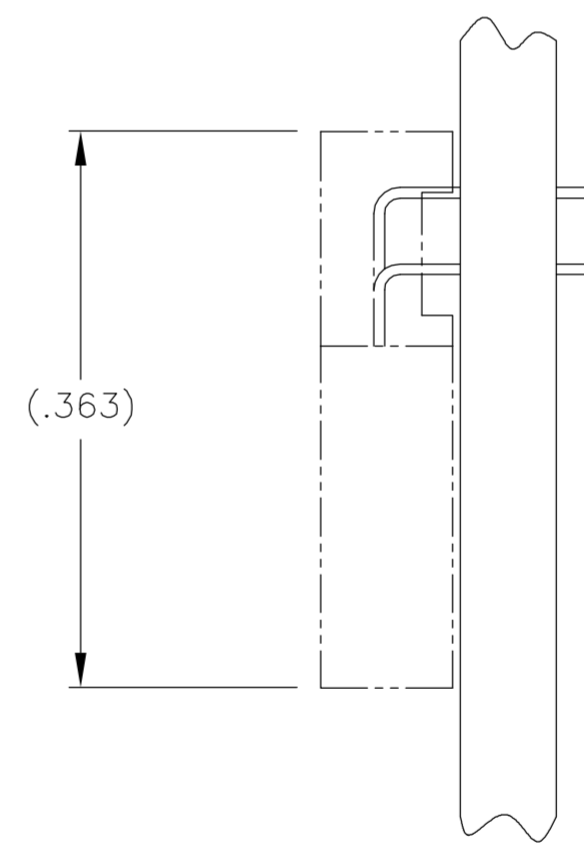
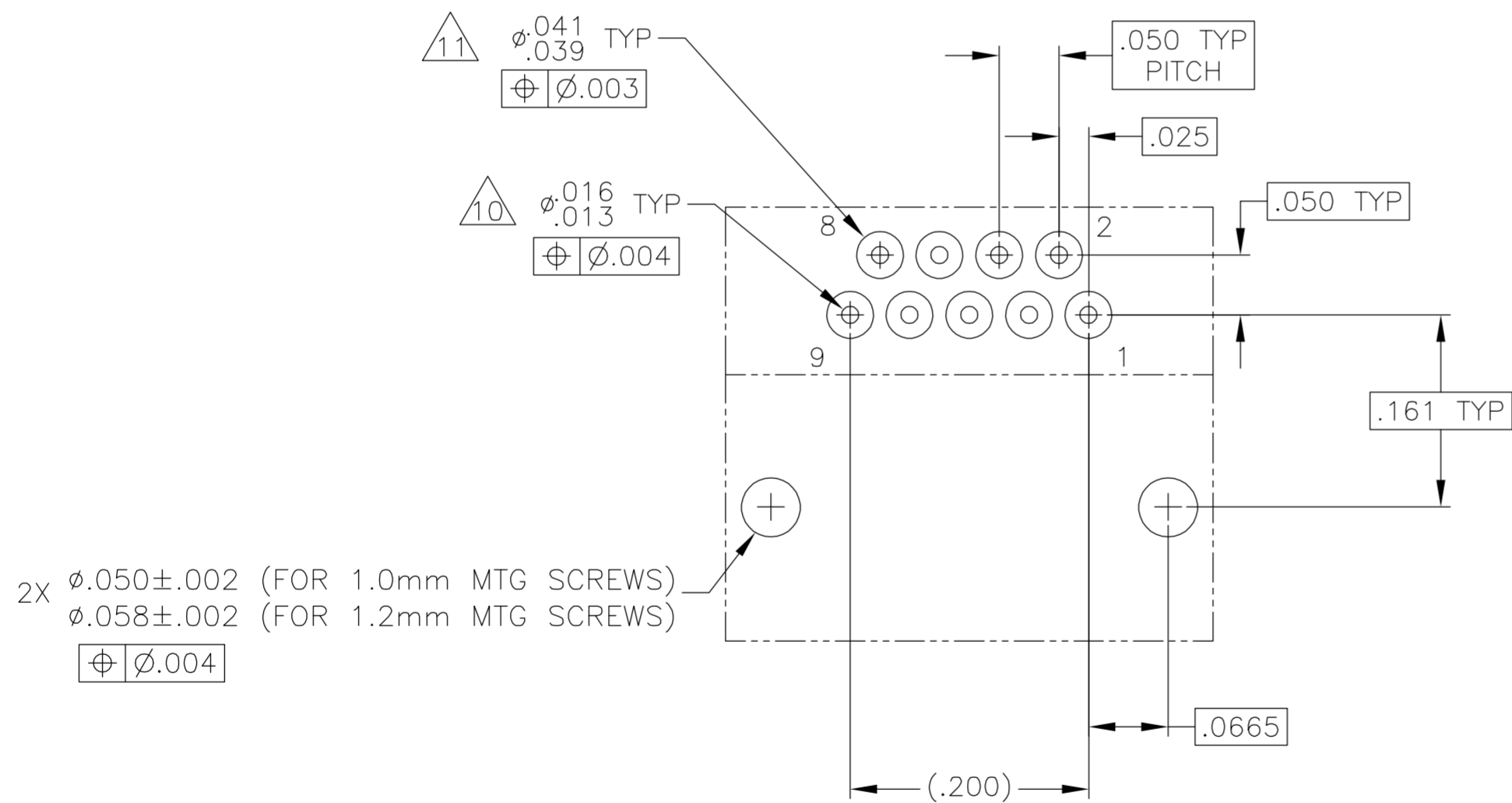
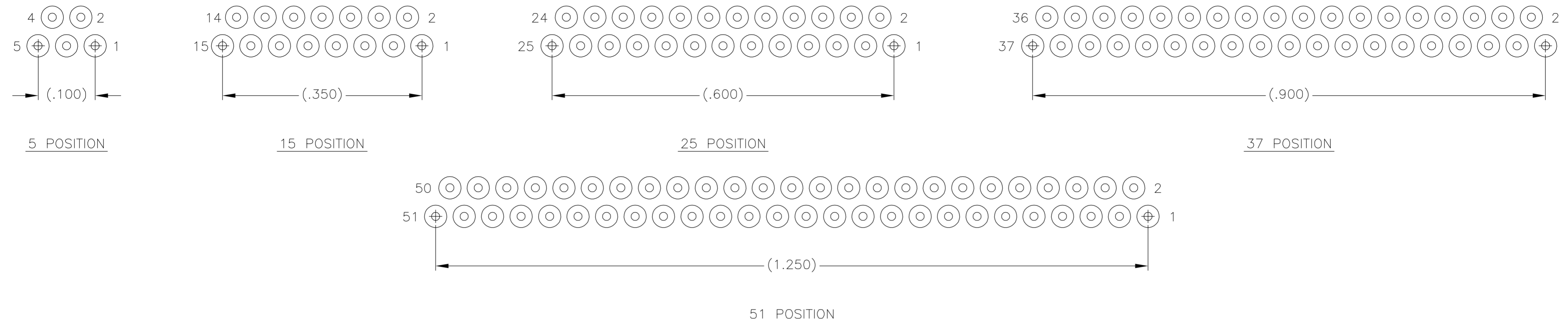

TYPICAL PCB LAYOUT
 SIZE 09 SHOWN FOR REFERENCE

- 9. POSITIONAL TOLERANCES FOR BASIC DIMENSIONED FEATURES ARE RELATIVE TO FIDUCIALS OR SOME SIMILAR DATUM REFERENCES DEFINED BY PCB DESIGNER.
- 10. PLATED THROUGH HOLES
- 11. SOLDER PADS
- 12. ALL THROUGH HOLE LAYOUTS ARE AS VIEWED FROM TOP OF PCB.

THIS DRAWING IS A CONTROLLED DOCUMENT.		DWN D. RYAN 06-22-00	Tyco Electronics Corporation Harrisburg, PA 17105	
DIMENSIONS: INCHES		CHK M. STORRY 06-22-00	NAME	
TOLERANCES UNLESS OTHERWISE SPECIFIED:		APVD -	PRODUCT SPEC	
ϕ 0 PLC \pm - ϕ 1 PLC \pm - ϕ 2 PLC \pm .010 ϕ 3 PLC \pm .005 ϕ 4 PLC \pm - ANGLES \pm 1°		APPLICATION SPEC		RECEPTACLE ASSEMBLY, HORIZONTAL MOUNT, THROUGH HOLE, 1 ROW TO 2 ROW, .050 SPACING, PLASTIC OR METAL
MATERIAL SEE NOTES	FINISH SEE NOTES	WEIGHT -	SIZE A2	RESTRICTED TO
CUSTOMER DRAWING		SCALE 8:1	DRAWING NO 0PUN9	REV T
		SHEET 2 of 2	CAGE CODE 1589469	