



PRODUCT OVERVIEW

D1U54P-W-450-12-HxxC is a series of very high efficiency, 450 watt power factor corrected front end supplies, providing a 2Vdc main output and standby output. An active (digital) current share characteristic is provided to allow units to operate in parallel and share load current. The power supply may be hot plugged; recovers from overtemperature faults, and has status LEDs on the front panel in addition to hardware signal logic and PMBus™ status signals. The compact low profile 1U package and 14.8W/cubic inch power density make them ideal for delivering reliable, efficient power to networking equipment, workstations, storage systems and other 12Vdc distributed power architectures.

ORDERING GUIDE

Part Number	Power Output 90-264Vac	Main Output	Standby Output	Airflow
D1U54P-W-450-12- HA3C	450W	12Vdc	5Vdc	Front to Back
D1U54P-W-450-12- HB3C			12Vdc	
D1U54P-W-450-12- HA4C			5Vdc	Back to front
D1U54P-W-450-12- HB4C			12Vdc	

FEATURES

- 450W output power
- 12Vdc main output
- 5Vdc & 12Vdc standby output options
- <1U height:
[54.5mm x 228.6mm x 40mm](#)
(2.15" x 9.0" x 1.57")
- Card Edge DC Output and Signal I/O Connector
- IEC 60320-C14 AC Inlet
- 14.8 Watts per cubic inch density
- N+1 redundancy capable
- Active (digital) current sharing on 12Vdc main output; both outputs include ORing FET circuit
- Overvoltage, Overcurrent, Overtemperature protection
- Internal cooling fan (variable speed)
- PMBus™/I2C interface with status indicators
- RoHS compliant
- Two Year Warranty

INPUT CHARACTERISTICS

Parameter	Conditions	Min.	Nom.	Max.	Units
Input Source Voltage Operating Range		90	100/240	264	Vac
Input Source Frequency		47	50/60	63	Hz
Turn-on Input Voltage	Ramp up	74		84	Vac
Turn-off Input Voltage	Ramp down	70		80	Vac
Maximum current at Vin = 100Vac	450W; 100-240Vac			6	Arms
Inrush Current	Cold start between 0 to 200msec			20	Apk
Power Factor	At 230Vac, 100% load	0.96			W/VA
	At 230Vac, 50% load	0.95			
Efficiency	At 230Vac 20% load		90		%
	At 230Vac 50% load		94		
	At 230Vac 100% load		91		

OUTPUT VOLTAGE CHARACTERISTICS

Nominal Output Voltage	Parameter	Conditions	Min.	Typ.	Max.	Units
12V	Output Set Point Accuracy	50% load; Tamb =25°C	11.96	12.00	12.04	Vdc
	Line and Load Regulation ²	Setpoint; temperature; line and load	-1.0%		+1.5	%
	Ripple Voltage & Noise ^{1,2}	20MHz Bandwidth			120	mV p-p
	Output Current Range		0		37.5	A
	Load Capacitance		500		4000	µF
5VSB	Nominal Output Voltage			5.0		Vdc
	Line and Load Regulation ³		4.76		5.24	Vdc
	Ripple Voltage & Noise ¹³	20MHz Bandwidth			75	mV p-p
12VSB	Output Current		0		2	A
	Load Capacitance		250		1000	µF
	Nominal Output Voltage			12.0		Vdc
	Line and Load Regulation ³		11.7		12.3	Vdc
	Ripple Voltage & Noise ¹³	20MHz Bandwidth			120	mV p-p
Output Current			0		1	A
Load Capacitance			250		1000	µF

¹ Ripple and noise are measured with 0.1 µF of ceramic capacitance and 10 µF of tantalum capacitance on each of the power supply outputs. A short coaxial cable to the measurement 'scope input, is used.

² Minimum Load of 1.75A

³ Minimum load of 0.28A



Available now at:
www.murata-ps.com/en/3d/acdc.html



For full details go to
www.murata-ps.com/rohs



Test Certificate
and Test Report



OUTPUT CHARACTERISTICS					
Parameter	Conditions	Min.	Typ.	Max.	Units
Startup Time	AC ramp up			3	s
Current sharing accuracy (main 12Vdc output)	> 10% load (* % total Current)	-5		+5	* %
Transient Response (Single transient, main 12Vdc output)	Load step of 50% max. load, > 2.5A load, 1A/μs slew rate	-5		+5	%
	Recovery Time to within 1% Vnom		2		ms
Transient Response (Single transient, Standby output)	Load step of 50% max. load, > 10% Max load, 1A/μs slew rate	-5		+5	%
	Recovery Time to within 1% Vnom		2		ms
Hot Swap Transients		-5		+5	%
Holdup Time (Total Effective Hold Up - See Timing Waveforms)	Full AC Input Source Range; 450W maximum total output power	12			ms
	Full AC Input Source Range; 270W maximum total output power	20			ms

ENVIRONMENTAL CHARACTERISTICS					
Parameter	Conditions	Min.	Typ.	Max.	Units
Storage Temperature Range		-40		70	°C
Operating Temperature Range	90V-264Vac, 450W	-5		50	
Operating Humidity	Noncondensing; +45°C	5		90	%
Storage Humidity		5		95	
Altitude (without derating at 40°C)				3000	m
Acoustic noise levels	25°C, 50%load		45	50	dB
Shock	30G non-operating				
Operational Vibration	Sine sweep; 5-200Hz, 2G; random vibration, 5-500Hz, 1.11G				
MTBF (Target)	Per Telcordia SR-332 Issue 3 M1C3 at 40°C		520K		hrs
Safety Approval Standards (Planned; Pending Submission)	CAN/CSA C22.2 No 60950-1: 2007, A2: 2014 UL 60950-1-2014 IEC60950-1:2005+A2:2013 EN 60950-1:2006+A2:2013 BSMI: CNS14336-1 (1999/09/30), CNS13438 (1995/06/01) CCC: GB4943.1-2011; GB/T9254-2008; GB17625.1-2012 KCC: K60950-1 (2011-12) BIS: IS 13252 (PART1): 2010 IEC 60950-1 : 2005				
Input Fuse	Power Supply has internal 8A/250V fast blow fuse on the AC line input				
Weight	1.51 lbs (0.685 kg)				

PROTECTION CHARACTERISTICS						
Output	Parameter	Conditions	Min.	Typ.	Max.	Units
12V	Overtemperature (intake)	Auto-restart with 4°C hysteresis for recovery (warning issued at 70°C)		75		°C
	Overvoltage	Latching	13.0		14.5	Vdc
	Overcurrent (target)	The output shall shutdown when an overcurrent condition is detected. It will auto restart after 1sec; however if the overcurrent condition is re-detected the output will once again shutdown. The output will once again re-start, however if the overcurrent condition persists it will latch of after the fifth unsuccessful attempt. To reset the latch it will be necessary to toggle the PS_ON_L signal or recycle the incoming DC source.	40		50	Adc
5VSB	Overvoltage	Latching	5.4		6.0	Vdc
	Overcurrent	The output shall shutdown when an overcurrent is detected. It will auto restart after 2sec; however if the overcurrent is re-detected the output will once again shutdown. This cycle will occur indefinitely while the overcurrent condition persists.	2.1		3.0	Adc
12VSB	Over-Voltage	Latching; toggle PS_ON or recycle DC input to reset	13.0		14.5	Vdc
	Over-Current	The output shall shutdown when an overcurrent is detected. It will auto restart after 2sec; however if the overcurrent is re-detected the output will once again shutdown. This cycle will occur indefinitely while the overcurrent condition persists.	1.2		2	Adc

ISOLATION CHARACTERISTICS					
Parameter	Conditions	Min.	Typ.	Max.	Units
Insulation Safety Rating	Input to Output - Reinforced	3000			Vrms
	Input to Chassis - Basic	1500			Vrms
Isolation	Output to Chassis	500			Vdc

EMISSIONS AND IMMUNITY		
Characteristic	Standard	Compliance
Input Current Harmonics	IEC/EN 61000-3-2	Complies
Voltage Fluctuation and Flicker	IEC/EN 61000-3-3	Complies
Conducted Emissions	FCC 47 CFR Part 15 CISPR 22/EN55022	Class A with 6dB margin
ESD Immunity	IEC/EN 61000-4-2	Level 4 criteria A
Radiated Field Immunity	IEC/EN 61000-4-3	Level 3 criteria B
Electrical Fast Transients/Burst Immunity	IEC/EN 61000-4-4	Level 3 criteria A
Surge Immunity	IEC/EN 61000-4-5	1. EN61000-4-5, Lev. 3 (Com. Mode: 2kV, 12Ω, Diff. Mode: 1kV, 2Ω), criteria A ¹ 2. GR-1089-CORE (NEBS) Level 1 Table 4-30 (Com/Diff. Mode: 2kV, 2Ω) ¹
RF Conducted Immunity	IEC/EN 61000-4-6	Level 3 criteria A
Magnetic Field Immunity	IEC/EN 61000-4-8	3 A/m criteria B
Voltage Dips, Interruptions	IEC/EN 61000-4-11	230V _{in} , 80% load, Phase 0°, Dip 100% Duration 10ms (A) 230V _{in} , 50% load, Phase 0°, Dip 100% Duration 20ms (VSB:A, V1:B) 230V _{in} , 100% load, Phase 0°, Dip 100% Duration > 20ms (VSB, V1:B)

¹ tests are performed at 50% maximum load, and with minimum capacitance at both outputs

STATUS INDICATORS AND CONTROL SIGNALS	
INPUT LED	
Condition	LED Status
Input Voltage Present	Solid Green
Input Voltage fault or warning	Blinking Green
Input off	Off
POWER LED	
Condition	LED Status
Fault concurrent indication via PMBus Status_x registers	Solid Amber
Warning, concurrent indication via PMBus Status_x registers	Blinking Amber
Standby, 12Vdc Main output off, Vstby On	Blinking Green
Power Good 12Vdc Main output on, Vstby On	Solid Green
Power Off 12Vdc Main output off, Vstby Off	Off

STATUS AND CONTROL SIGNALS			
Signal Name	I/O	Description	Interface Details
INPUT_OK (AC Source) Link to connector pin	Output	The signal output is driven high when input source is available and within acceptable limits. The output is driven low to indicate loss of input power. There is a minimum of 1ms pre-warning time before the signal is driven low prior to the PWR_OK signal going low. The power supply must ensure that this interface signal provides accurate status when AC power is lost.	Pulled up internally via 10K to VDD*. A logic high >2.0Vdc A logic low <0.8Vdc Driven low by internal CMOS buffer (open drain output).
PW_OK (Output OK) Link to connector pin	Output	The signal is asserted, driven high, by the power supply to indicate that the main output is valid. Should a main output or standby output fault occur, the PW_OK signal will de-assert + driven low. 5V & 3.3V Standby output products do not de-assert the PW_OK signal during OCP event on the standby output. PW_OK output is driven low to indicate that the Main output is outside of lower limit of regulation.	Pulled up internally via 10K to VDD*. A logic high >2.0Vdc A logic low <0.8Vdc Driven low by internal CMOS buffer (open drain output).
SMB_ALERT (FAULT/WARNING) Link to connector pin	Output	The signal output is driven low to indicate that the power supply has detected a warning or fault and is intended to alert the system. This output must be driven high when the power is operating correctly (within specified limits). The signal will revert to a high level when the warning/fault stimulus (that caused the alert) is removed. As reported by PMBus Status_x Registers, with exception of Status_CML.	Pulled up internally via 10K to VDD*. A logic high >2.0Vdc A logic low <0.8Vdc Driven low by internal CMOS buffer (open drain output).
PRESENT_L (Power Supply Absent) Link to connector pin	Output	The signal is used to detect the presence (installation) of a PSU by the host system. The signal is connected to PSU logic +VSB_Return within the power module.	Passive connection to +VSB_Return. A logic low <0.8Vdc
PS_ON (Power Supply Enable/Disable) Link to connector pin	Input	This signal is pulled up internally to the internal housekeeping supply (within the power supply). The power supply main 12Vdc output will be enabled when this signal is pulled low to +VSB_Return. In the low state the signal input shall not source more than 1mA of current. The 12Vdc output will be disabled when the input is driven higher than 2.4V, or open circuited. Cycling this signal shall clear latched fault conditions.	Pulled up internally via 10K to VDD*. A logic high >2.0Vdc A logic low <0.8Vdc Input is via CMOS Schmitt trigger buffer.
PS_KILL Link to connector pin	Input	This signal is used during hot swap to disable both outputs during hot swap extraction. The input is pulled up internally to VDD* (within the power supply). The signal is provided on a short (lagging pin) and should be connected to +VSB_Return.	Pulled up internally via 10K to VDD*. A logic high >2.0Vdc A logic low <0.8Vdc Input is via CMOS Schmitt trigger buffer.
ADDR (Address Select) Link to connector pin	Input	An analog input that is used to set the address of the internal slave devices (EEPROM and microprocessor) used for digital communications. Connection of a suitable resistor to +VSB_Return, in conjunction with an internal resistor divider chain, will configure the required address. See configuration table for details.	DC voltage between the limits of 0 and +3.3Vdc.
SCL (Serial Clock) Link to connector pin	Both	A serial clock line compatible with PMBus™ Power Systems Management Protocol Part 1 – General Requirements Rev 1.1. No additional internal capacitance is added that would affect the speed of the bus. The signal is provided with a series isolator device to disconnect the internal power supply bus in the event that the power module is unpowered,	** VIL is 0.8V maximum VOL is 0.4V maximum when sinking 3mA VIH is 2.1V minimum
SDA (Serial Data) Link to connector pin	Both	A serial data line compatible with PMBus™ Power Systems Management Protocol Part 1 – General Requirements Rev 1.1. The signal is provided with a series isolator device to disconnect the internal power supply bus in the event that the power module is unpowered,	** VIL is 0.8V maximum VOL is 0.4V maximum when sinking 3mA VIH is 2.1V minimum
V1_SENSE V1SENSE_RTN	Input	Remote sense connections intended to be connected at and sense the voltage at the point of load. The voltage sense will interact with the internal module regulation loop to compensate for voltage drops due to connection resistance between the output connector and the load. If remote sense compensation is not required then the voltage can be configured for local sense by: 1. V1_SENSE directly connected to power gold fingers P1-P8 (inclusive) 2. V1_SENSE_RTN directly connected to gold fingers P9 to P16 (inclusive)	Compensation for a up to 0.12Vdc total connection drop (output and return connections).
ISHARE Link to connector pin	Bi-Directional Digital Bus	The current sharing signal is connected between sharing units (forming an ISHARE bus). It is an input and/or an output (bi-directional analog bus) as the voltage on the line controls the current share between sharing units. A power supply will respond to a change in this voltage but a power supply can also change the voltage depending on the load drawn from it. On a single unit the voltage on the pin (and the common ISHARE bus would read 8VDC at 100% load (module capability). For two identical units sharing the same 100% load this would read 4VDC for perfect current sharing (i.e. 50% module load capability per unit).	Analogue voltage: +8V maximum; 10K to +12V_RTN

*VDD is an internal voltage rail derived from VSB and an internal housekeeping rail (“diode ORed”) and is compatible with the voltage tolerances of VSB).

**For robust PMBus communications, it is recommended SDA and SCA lines be pulled up via external resistors to a voltage of 3.3V or greater.

TIMING SPECIFICATIONS

Turn-On Delay & Output Rise Time:

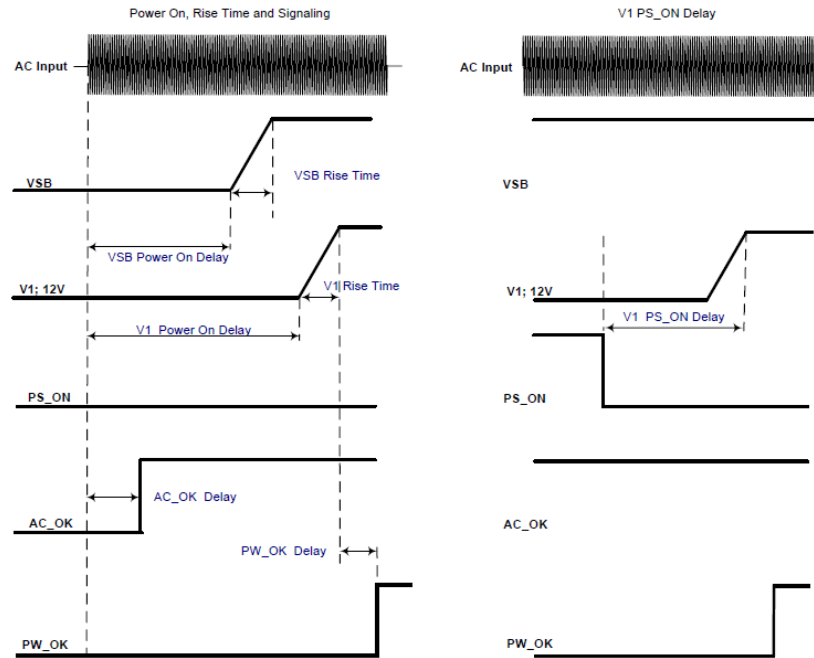

1. The turn-on delay after application of AC input within the operating range shall as defined in the following tables.
2. The output rise times shall be measured from 10% of the nominal output to the lower limit of the regulation band as defined in the following tables.

Time	Min	Max
Vsb Rise time, from 10% to 90% Nominal output VDC	-	60ms
V1 Rise time, form 10% to 90% Nominal output VDC	6ms	60ms
Vsb Power-on-delay	-	2700ms
V1 Power-on-delay	-	3000ms
V1 PS_ON delay	100ms	150ms
V1 PWOK delay	100ms	300ms
ACOK detect	300ms	1500ms

TIMING SPECIFICATIONS

Turn-Off (Shutdown by PS_ON)

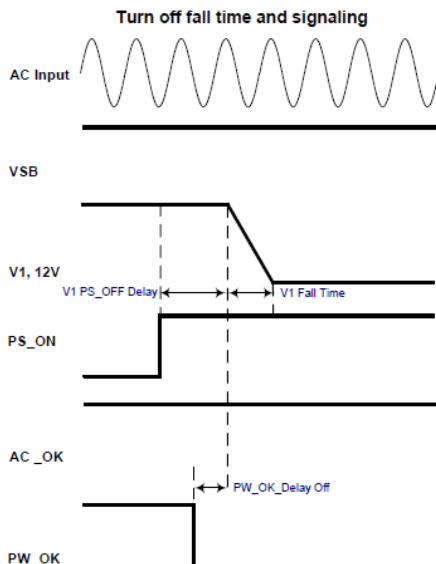

Turn-Off Timing	Min	Max	Notes
V1 Fall time	-	-	Must be monotonic
V1 PS_OFF delay	-	10ms	
PW_OK delay off	1ms	-	

1. Note this characteristic is applicable for the main 12Vdc output shutdown from PS_ON pulled high.

TIMING SPECIFICATIONS

Power Removal Holdup

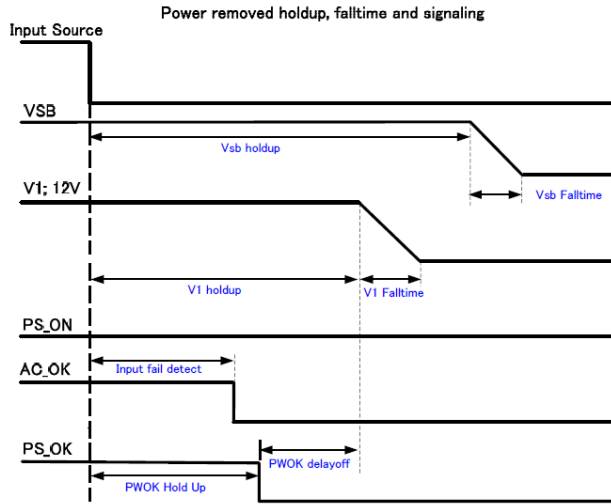

Power Removal Timing	Min	Max	Notes
Vsb holdup	40ms	2S	100% load
V1 holdup (Effective Total)	12ms	-	100% load
Input fail detect	5ms	11ms	100% load
PWOK delay off	1ms	-	100% load
PWOK Hold Up	11ms	-	100% load

OUTPUT CONNECTOR & SIGNAL INTERFACE

Gold Finger Layout & Pin Assignment

Mating Connector: FCI 10126933080820xALF; "Straddle" Connector

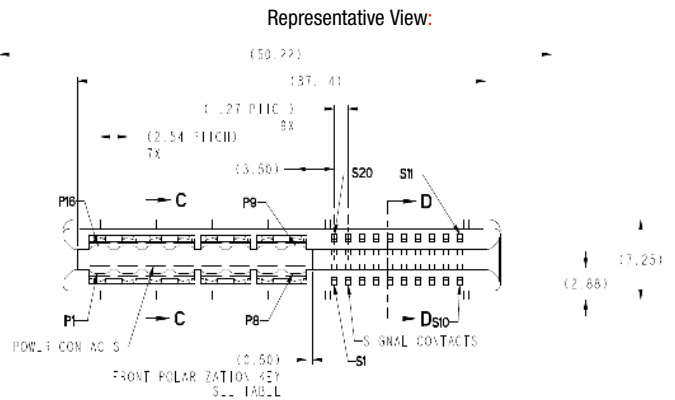
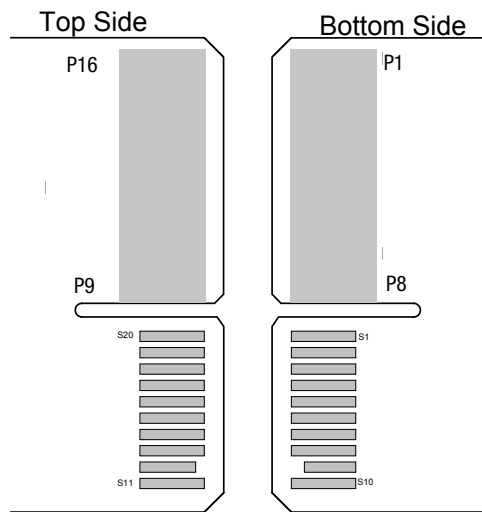

Notes: Gold Fingers S9 (PS_KILL) and S12 (PS PRESENT/L) are "last to make; fist to break" short pins. For illustration purposes only, actual product may appear different. Dimensions as follows:

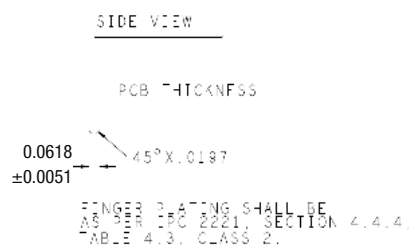
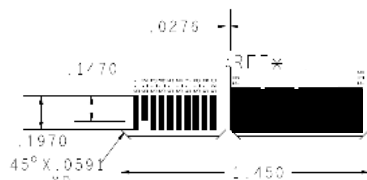

OUTPUT CONNECTOR PIN ASSIGNMENTS - D1U54P-W-450-12-HBxC

(Power Supply Gold Finger/Card)

Pin#	Signal Name	Description/Comment
P1-P8 inclusive	V1 (+12VOUT)	+12Vdc Main Output
P9-P16 inclusive	V1 (+12VOUT) RTN/PGND)	+12Vdc Main Output and Standby Output Return
S1	+VSB	Standby Output
S2	+VSB	Standby Output
S3	Reserved	No User Connection
S4	ISHARE	Active Current Share Bus; link back to signal definition
S5	SDA	I ² C Serial Data Line; link back to signal definition
S6	SCL	I ² C Serial Clock Line; link back to signal definition
S7	SMB_ALERT	Alert signal to host system; link back to signal definition
S8	PS_ON	Remote On/Off (Enable/Disable) ; link back to signal definition
S9	PS_KILL	Power Supply "kill"; short pin ; link back to signal definition
S10	INPUT_OK	AC Input Source Present & "OK" ; link back to signal definition
S11	PW_OK	Output DC Power "OK"; link back to signal definition
S12	PS PRESENT	Power Module Present; short pin; link back to signal definition
S13	Reserved	No User Connection
S14	Reserved	No User Connection
S15	V1_SENSE_RTN	+12Vdc Main Output Remote Sense Return
S16	V1_SENSE	+12Vdc Main Output Remote Sense
S17	ADDR	Address Protocol Selection; (select address by use of the appropriate pull down resistor – see table below) ; link back to signal definition
S18	Reserved	No User Connection
S19	+VSB	Standby Output
S20	+VSB	Standby Output

ADDR ADDRESS SELECTION

ADDR pin (A3) resistor to GND (K-ohm)*	Power Supply Main Controller (Serial Communications Slave Address)	Power Supply External EEPROM (Serial Communications Slave Address)
0.82	0xB0	0xA0
2.7	0xB2	0xA2
5.6	0xB4	0xA4
8.2	0xB6	0xA6
15	0xB8	0xA8
27	0xBA	0xAA
56	0xBC	0xAC
180	0xBE	0xAE

* The resistor shall be +/-5% tolerance
[Link back to Address Definition](#)

WIRING DIAGRAM FOR OUTPUT

Dotted lines show optional remote sense connections.
Optional remote sense lines can be attached to a load that is a distance away from the power supply to improve regulation at the load.

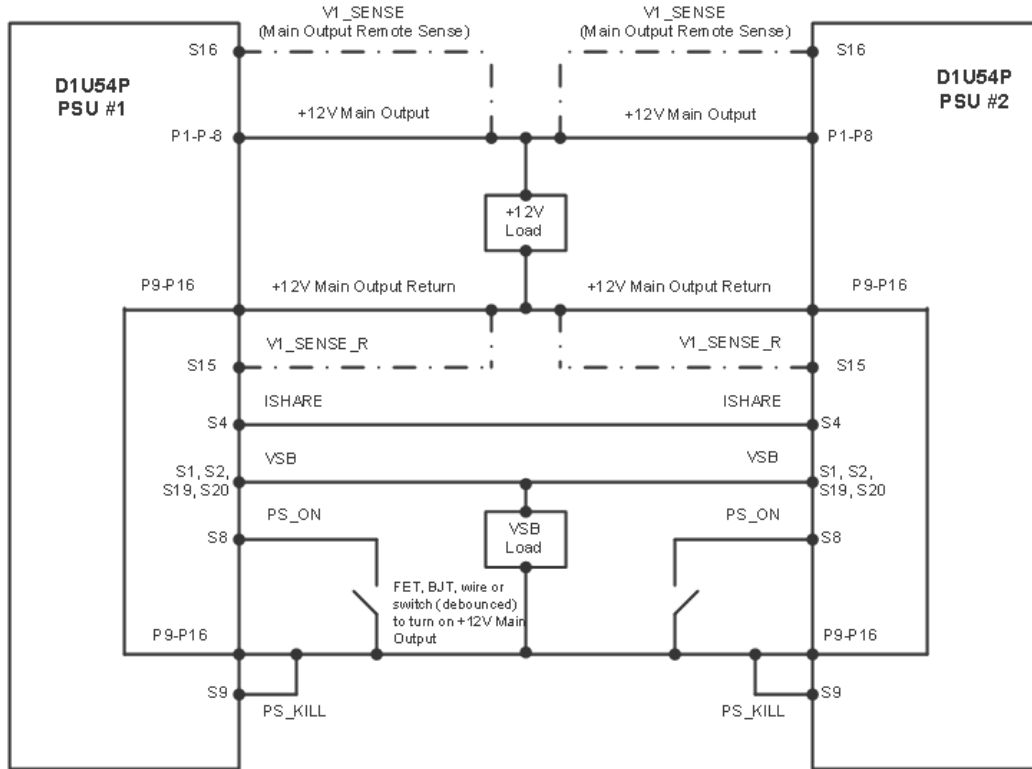

CURRENT SHARE NOTES

1. Main Output: Current sharing is achieved using the active current share method details.)
2. Current sharing can be achieved with or without the remote (V_SENSE) connected to the common load.
3. +VSB Outputs can be tied together for redundancy but total combined output power must not exceed the rated standby power. The +VSB output has an internal ORing MOSFET for additional redundancy/internal short protection.
4. The current sharing pin B5 is connected between sharing units (forming an ISHARE bus). It is an input and/or an output (bi-directional analog bus) as the voltage on the line controls the current share between sharing units. A power supply will respond to a change in this voltage but a power supply can also change the voltage depending on the load drawn from it. On a single unit the voltage on the pin (and the common ISHARE bus would read 8VDC at 100% load. For two units sharing the same load this would read 4VDC for perfect current sharing (i.e. 50% load per unit).
5. The load for both the main 12Vdc and the VSB rails at initial startup shall not be allowed to exceed the capability of a single unit. The load can be increased after a delay of 3sec (minimum), to allow all sharing units to achieve steady state regulation.

Mechanical Envelope

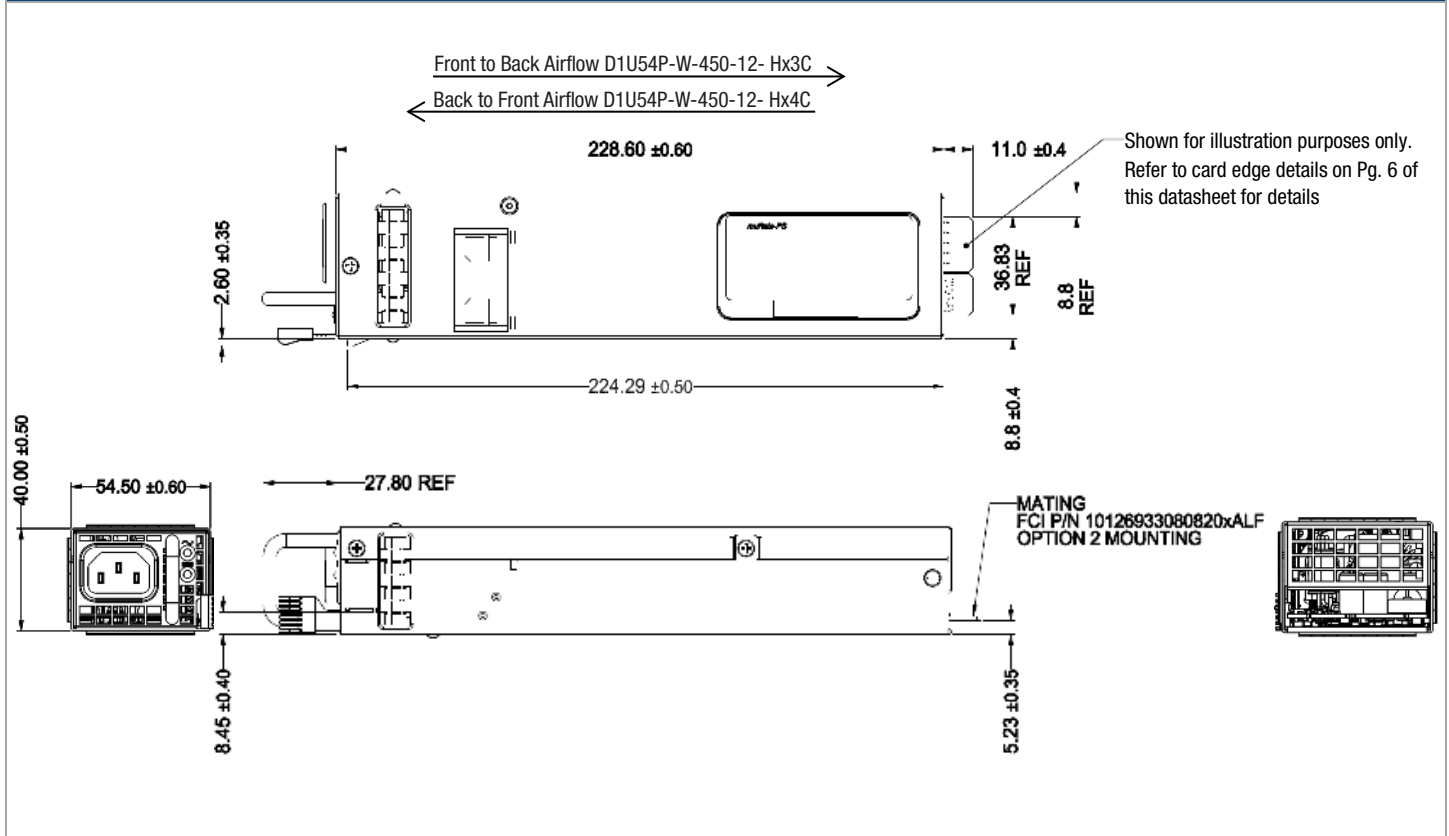

1. Reference file: I:\Eng_wip\UserPDDwg\1909M1909_Drawing for Product Datasheet_20170407
2. For illustration purposes of the envelope and main features only. Not all details visible on actual product are represented. 3D model is available upon request.
3. Dimensions are in mm, Not to Scale

[Link Back to Features](#)

OPTIONAL ACCESSORIES

Description	Part Number
12Vdc D1U54P 450W series Output Connector Card	D1U54P-12-EDGE

APPLICATION NOTES

Document Number	Description	Link
ACAN-72	D1U54P-x Communication Protocol	http://power.murata.com/datasheet/?/data/apnotes/acan-72.pdf
ACAN-73	Output Connector Card with edge connector	http://power.murata.com/datasheet/?/data/apnotes/acan-73.pdf

Murata Power Solutions, Inc.
129 Flanders Rd. Westborough,
Ma 01581, USA.
ISO 9001 and 14001 REGISTERED



This product is subject to the following operating requirements and the Life and Safety Critical Application Sales Policy: Refer to: <http://www.murata-ps.com/requirements/>

Murata Power Solutions, Inc. makes no representation that the use of its products in the circuits described herein, or the use of other technical information contained herein, will not infringe upon existing or future patent rights. The descriptions contained herein do not imply the granting of licenses to make, use, or sell equipment constructed in accordance therewith. Specifications are subject to change without notice. © 2018 Murata Power Solutions, Inc.