

# QUICK START GUIDE FOR DEMONSTRATION CIRCUIT 959

## HIGH-POWER MULTI-OUTPUT SUPPLY WITH POE CONTROLLER

### LTC4257CDD-1/LTC3825EFE

## DESCRIPTION

Demonstration circuit 959 is a high-power triple output (37.4W) supply featuring the LTC3825 with the LTC4257-1. This board acts as a pre-standard high power Power-over-Ethernet (PoE) Powered Device (PD) and connects at the RJ45 to a compatible high power Power Sourcing Equipment (PSE) device. The LTC4257-1 provides IEEE802.3af standard PoE PD interfacing. When the PD is fully powered, the LTC4257-1 switches power over to the LTC3825. The

highly-integrated LTC3825, small supply utilizes an isolated flyback topology with synchronous rectification that requires no opto-isolator allowing for low-parts count. The DC959 output supplies are 5V @ 3A, 11.8V @ 0.5A, and 3.3V @ 5A.

**Design files for this circuit board and PSE solution are available. Call the LTC factory.**

 , LTC and LT are registered trademarks of Linear Technology Corporation.

**Table 1. Performance Summary ( $T_A = 25^\circ\text{C}$ )**

PARAMETER	CONDITION	VALUE
Input Voltage	In from PSE or auxiliary	37V to 57V
Output Voltage $V_{OUT}$	$V_{IN} = 37\text{V to } 57$ from PSE	5V $\pm 2.5\%$ @ 3A 11.8V $\pm 2\%$ @ 0.5A 3.3V $\pm 3\%$ @ 5A
Typical Output Ripple $V_{OUT}$	$V_{IN} = 48\text{V}$	5V: < 20mVpp @ 3A 11.8V: < 120mVpp @ 0.5A 3.3V: < 25mVpp @ 5A
Nominal Switching Frequency		250kHz
Efficiency	$V_{IN} = 48\text{V}$ , full output current	85.3% Typical
Isolation Voltage		1500VDC

## QUICK START PROCEDURE

DC959 is easy to set up to evaluate the performance of the LTC3825 with the LTC4257-1 in a high power PD application. Refer to Figure 1 for proper measurement equipment setup and follow the procedure below:

1. Place test equipment (voltmeter, ammeter, and load) across outputs 5V, 11.8V, and 3.3V.
2. Input supplies:
  - a. Connect a high power PSE with a CAT5 cable to RJ45 connector J1.
  - b. 37V to 57V option applied across  $V_{IN+}$  and  $V_{IN-}$  if PSE is not available.
3. Check for the proper output voltages 5V, 11.8V, and 3.3V.
4. Once the proper output voltages are established, adjust the loads within the operating range and observe the output voltage regulation, ripple voltage, efficiency and other parameters.

### OPERATING PRINCIPLES

A compatible high power PSE is connected to the DC959 at the RJ45 connector J1. As required by IEEE802.3af, a bridge is used across the data pairs and signal pairs. Schottky diodes are used at the input to improve efficiency over standard diode bridges. The LTC4257-1 provides IEEE802.3af standard PoE 25k signature resistance and is set for a power class 4. When the PD is powered and voltage is above the turn on UVLO, the LTC4257-1 signals a power good to the LTC3825 to begin operation and switches power over through MOSFET Q8 to allow for currents higher than standard PoE.

The LTC3825 regulates the output voltages by sensing the average of all the output voltages via a transformer winding during the flyback time. This allows for tight output regulation without the use of an opto-isolator, providing improved dynamic response and reliability. Synchronous rectification increases the conversion efficiency and cross-regulation effectiveness above a conventional flyback topology. No external driver ICs or delay circuits are needed to achieve synchronous rectification; a single resistor is all that is needed to program the synchronous rectifier's timing.

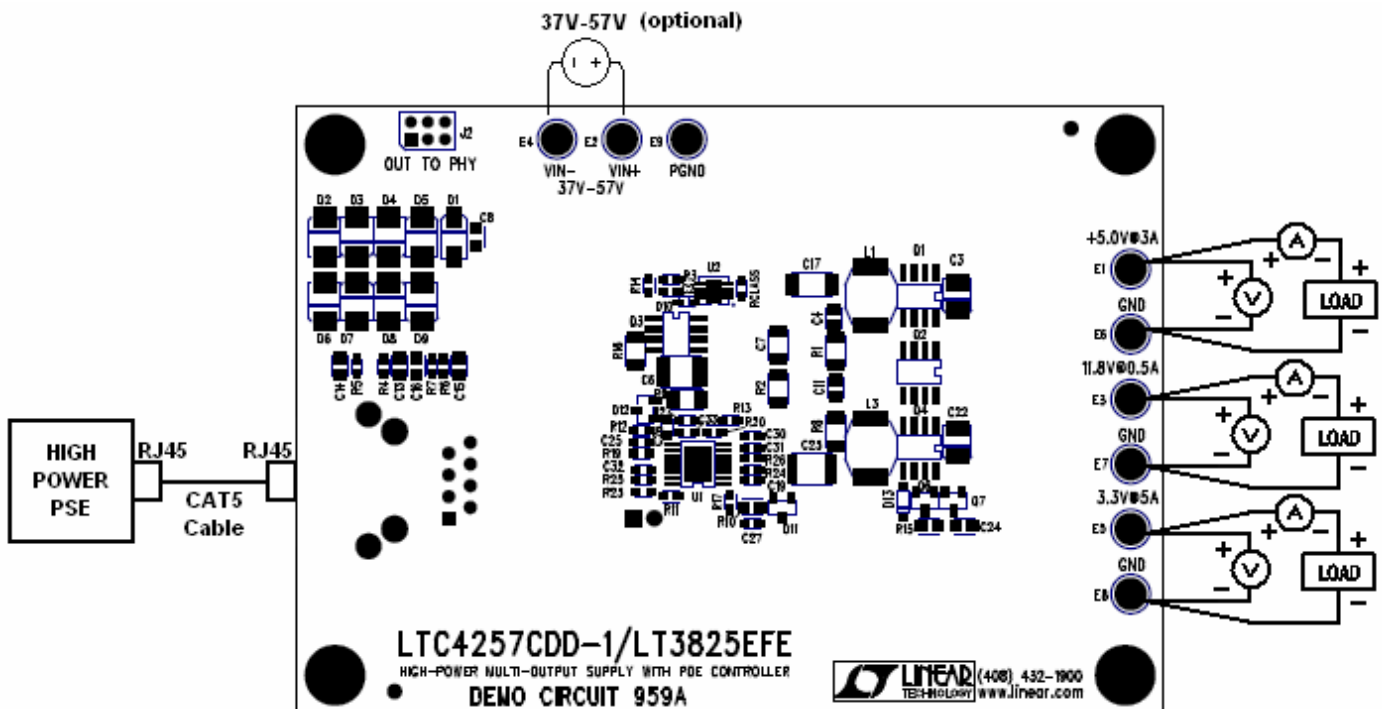

Figure 1. Proper measurement equipment setup

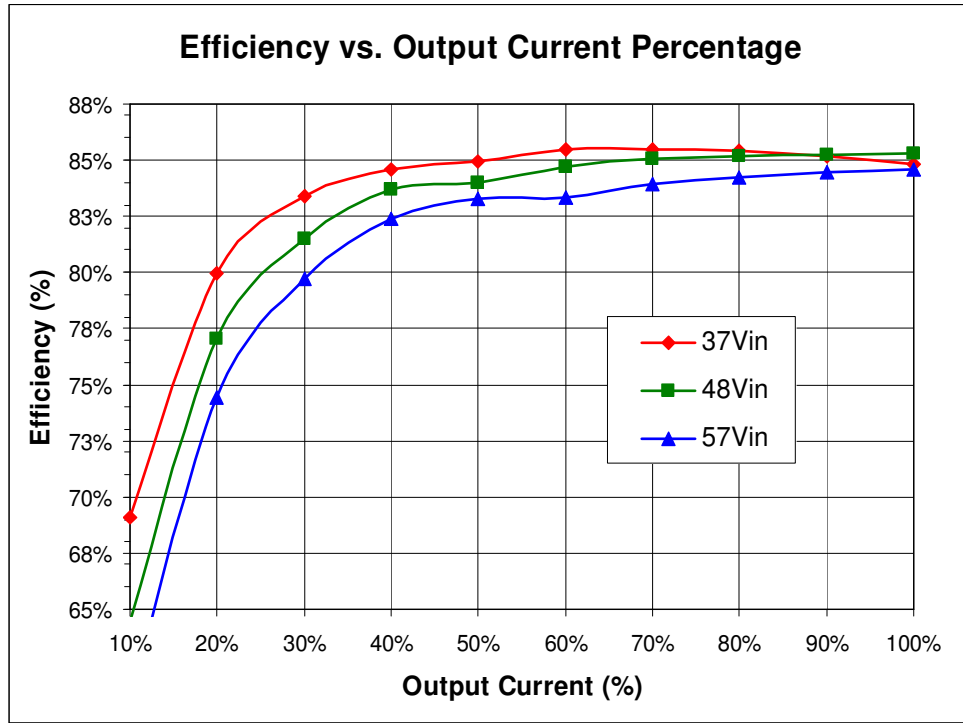
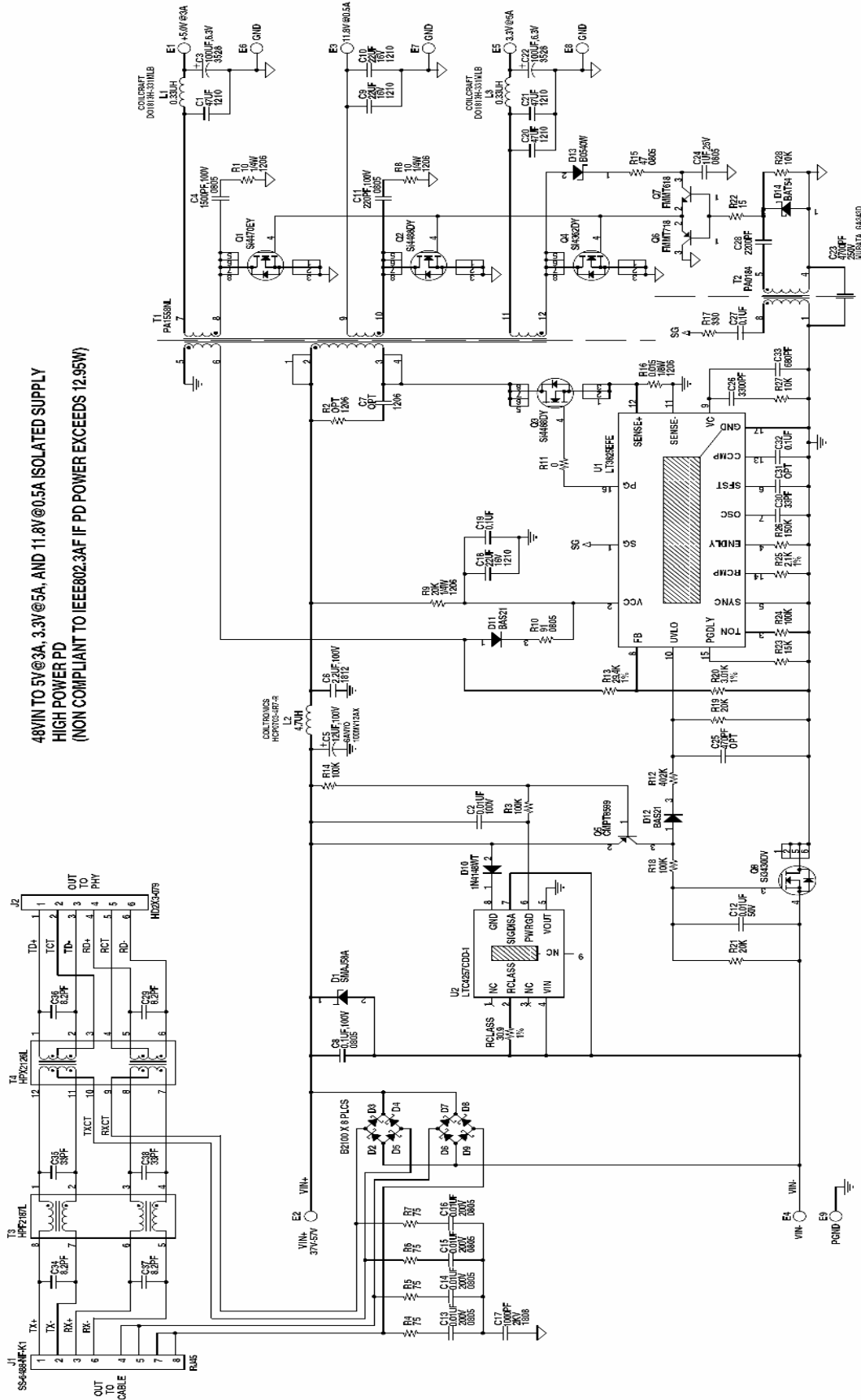

Figure 2. Efficiency curves for different input voltages.

# QUICK START GUIDE FOR DEMONSTRATION CIRCUIT 959

## HIGH-POWER MULTI-OUTPUT SUPPLY WITH POE CONTROLLER

48VIN TO 5V@3A, 3.3V@5A, AND 11.8V@0.5A ISOLATED SUPPLY  
HIGH POWER PD  
(NON COMPLIANT TO IEEE802.3AF IF PD POWER EXCEEDS 12.95W)



<b>CUSTOMER NOTICE</b>		LINEAR TECHNOLOGY HAS MADE A BEST EFFORT TO DESIGN A CIRCUIT THAT MEETS CUSTOMER-SPECIFIED REQUIREMENTS. HOWEVER, IT REMAINS THE CUSTOMER'S RESPONSIBILITY TO VERIFY PROPER AND RELIABLE OPERATION IN THE ACTUAL APPLICATION. COMPONENT SUBSTITUTION AND PRINTED CIRCUIT BOARD LAYOUT MAY SIGNIFICANTLY AFFECT CIRCUIT PERFORMANCE AND RELIABILITY. CONTACT LINEAR TECHNOLOGY APPLICATIONS ENGINEERING FOR ASSISTANCE. THIS CIRCUIT IS PROPRIETARY TO LINEAR TECHNOLOGY AND SUPPLIED FOR USE WITH LINEAR TECHNOLOGY PARTS.	
CONTRACT NO.	APPROVALS	1890 McCherry Blvd. Milpitas, CA 95035 Phone: (408)436-5000 Fax: (408)436-5001 E-Mail: ltc@linear.com	
DRWNL: KMT	CHECKED:	<b>LINEAR TECHNOLOGY</b> TITLE: SCHEMATIC HIGH-POWER MULTI-OUTPUT SUPPLY WITH POE CONTROLLER	
ENGINEER: RYANT	APPROVED:	SIZE	DWG NO.
DESIGNER:	DATE:	B	DC959A-1 * LTC4257DD-1/LT9825EFE
			REV
			A-1
			SHEET 1 OF 1

NOTES: UNLESS OTHERWISE SPECIFIED  
1. ALL RESISTORS ARE IN OHMS, Ω.  
ALL CAPACITORS ARE μΩ.