

ISL32430E, ISL32432E, ISL32433E, ISL32435E, ISL32437E

±40V Fault Protected, 3.3V to 5V, ±15V Common-Mode Range, RS-485/RS-422 Transceivers With Cable Invert and ±15kV ESD

FN7920
Rev.1.00
Feb 15, 2019

The [ISL32430E](#), [ISL32432E](#), [ISL32433E](#), [ISL32435E](#), and [ISL32437E](#) are 3.3V to 5V powered, fault protected, extended common-mode range differential transceivers for balanced communication. The RS-485 bus pins, driver outputs and receiver inputs, are protected against overvoltages up to ±40V and against ±15kV ESD strikes. Additionally, these transceivers operate in environments with common-mode voltages up to ±15V (exceeds the RS-485 requirement), making this RS-485 family one of the most robust on the market.

The transmitters are RS-485 compliant with $V_{CC} \geq 4.5V$ and deliver a 1.1V differential output voltage into the RS-485 specified 54Ω load even with $V_{CC} = 3V$.

The receiver (Rx) inputs feature a full fail-safe design that ensures a logic high Rx output if the Rx inputs are floating, shorted, or on a terminated but undriven (idle) bus. The Rx full fail-safe operation is maintained even when the Rx input polarity is switched (cable invert function on ISL32437E).

The ISL32437E includes a cable invert function that reverses the polarity of the Rx and Tx bus pins if the cable is misconnected during installation.

See [Table 1 on page 4](#) for key features and configurations by device number.

Related Literature

For a full list of related documents, visit our website:

- [ISL32430E](#), [ISL32432E](#), [ISL32433E](#), [ISL32435E](#), and [ISL32437E](#) device pages

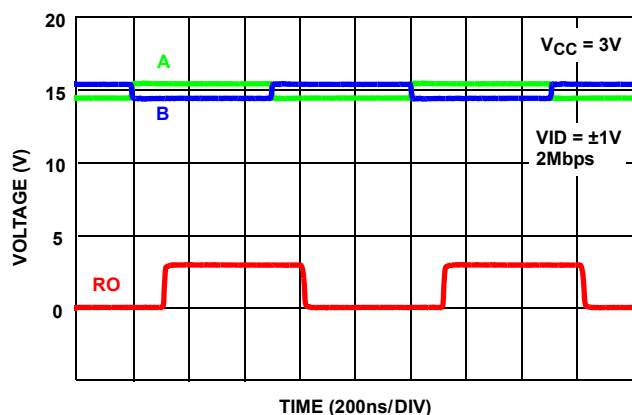

FIGURE 1. EXCEPTIONAL ISL32433E RX OPERATES AT >1Mbps EVEN WITH ±15V COMMON-MODE VOLTAGE

Features

- Fault protected RS-485 bus pins up to ±40V
- Extended common-mode range ±15V larger than required for RS-485
- ±15kV HBM ESD protection on RS-485 bus pins
- Wide supply range 3V to 5.5V
- Cable invert pin corrects for reversed cable connections while maintaining Rx full fail-safe functionality (ISL32437E only)
- 1/4 Unit load for up to 128 devices on the bus
- High transient overvoltage tolerance ±60V
- Full fail-safe (open, short, terminated) RS-485 receivers
- Choice of RS-485 data rates 250kbps or 1Mbps
- Low quiescent supply current 2.1mA
- Ultra low shutdown supply current 10μA
- Pb-free (RoHS compliant)

Applications

- Utility meters/automated meter reading systems
- Air conditioning systems
- Security camera networks
- Building lighting and environmental control systems
- Industrial/process control networks

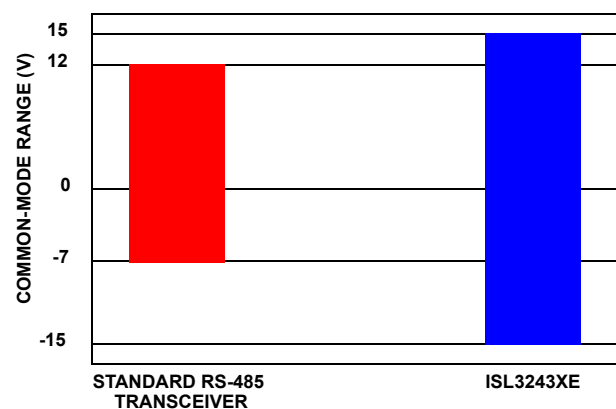

FIGURE 2. TRANSCEIVERS DELIVER SUPERIOR COMMON-MODE RANGE vs STANDARD RS-485 DEVICES

Typical Operating Circuits

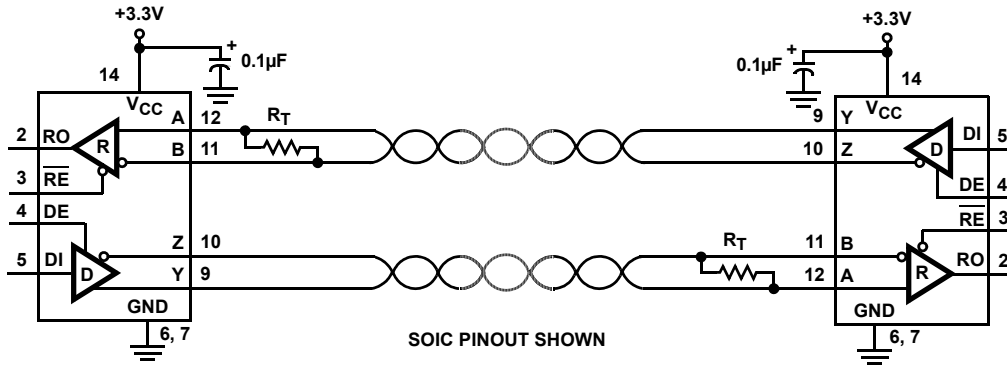

FIGURE 3. ISL32430E, ISL32433E FULL DUPLEX NETWORK

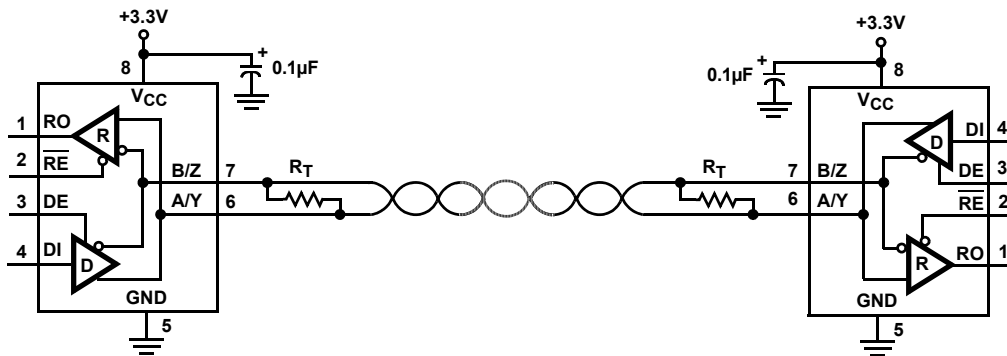

FIGURE 4. ISL32432E, ISL32435E HALF DUPLEX NETWORK

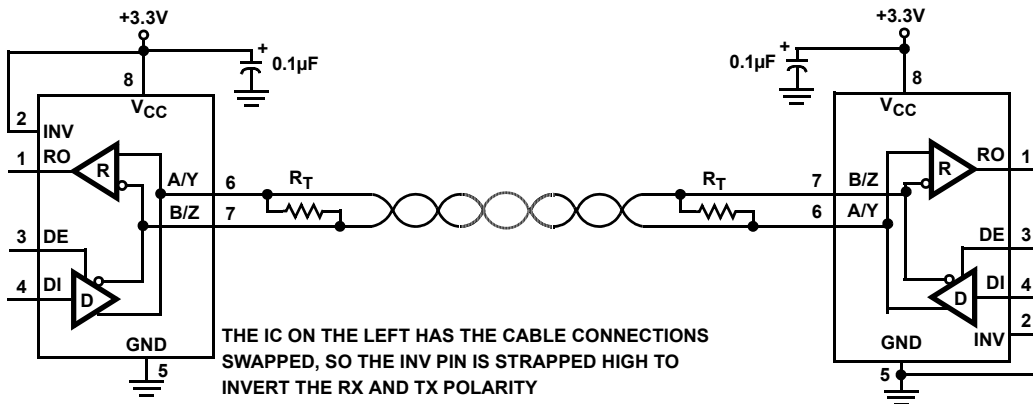

FIGURE 5. ISL32437E HALF DUPLEX NETWORK USING CABLE INVERT FUNCTION

Ordering Information

PART NUMBER (Notes 2, 3)	PART MARKING	TEMP. RANGE (°C)	TAPE AND REEL (Units) (Note 1)	PACKAGE (RoHS Compliant)	PKG. DWG. #
ISL32430EIBZ	ISL32430 EIBZ	-40 to +85	-	14 Ld SOIC	M14.15
ISL32430EIBZ-T	ISL32430 EIBZ	-40 to +85	2.5k	14 Ld SOIC	M14.15
ISL32430EIBZ-T7A	ISL32430 EIBZ	-40 to +85	250	14 Ld SOIC	M14.15
ISL32430EIUZ	2430E	-40 to +85	-	10 Ld MSOP	M10.118
ISL32430EIUZ-T	2430E	-40 to +85	2.5k	10 Ld MSOP	M10.118
ISL32430EIUZ-T7A	2430E	-40 to +85	250	10 Ld MSOP	M10.118
ISL32432EIBZ	32432 EIBZ	-40 to +85	-	8 Ld SOIC	M8.15
ISL32432EIBZ-T	32432 EIBZ	-40 to +85	2.5k	8 Ld SOIC	M8.15
ISL32432EIBZ-T7A	32432 EIBZ	-40 to +85	250	8 Ld SOIC	M8.15
ISL32432EIUZ	2432E	-40 to +85	-	8 Ld MSOP	M8.118
ISL32432EIUZ-T	2432E	-40 to +85	2.5k	8 Ld MSOP	M8.118
ISL32432EIUZ-T7A	2432E	-40 to +85	250	8 Ld MSOP	M8.118
ISL32433EIBZ	ISL32433 EIBZ	-40 to +85	-	14 Ld SOIC	M14.15
ISL32433EIBZ-T	ISL32433 EIBZ	-40 to +85	2.5k	14 Ld SOIC	M14.15
ISL32433EIBZ-T7A	ISL32433 EIBZ	-40 to +85	250	14 Ld SOIC	M14.15
ISL32433EIUZ	2433E	-40 to +85	-	10 Ld MSOP	M10.118
ISL32433EIUZ-T	2433E	-40 to +85	2.5k	10 Ld MSOP	M10.118
ISL32433EIUZ-T7A	2433E	-40 to +85	250	10 Ld MSOP	M10.118
ISL32435EIBZ	32435 EIBZ	-40 to +85	-	8 Ld SOIC	M8.15
ISL32435EIBZ-T	32435 EIBZ	-40 to +85	2.5k	8 Ld SOIC	M8.15
ISL32435EIBZ-T7A	32435 EIBZ	-40 to +85	250	8 Ld SOIC	M8.15
ISL32435EIUZ	2435E	-40 to +85	-	8 Ld MSOP	M8.118
ISL32435EIUZ-T	2435E	-40 to +85	2.5k	8 Ld MSOP	M8.118
ISL32435EIUZ-T7A	2435E	-40 to +85	250	8 Ld MSOP	M8.118
ISL32437EIBZ	32437 EIBZ	-40 to +85	-	8 Ld SOIC	M8.15
ISL32437EIBZ-T	32437 EIBZ	-40 to +85	2.5k	8 Ld SOIC	M8.15
ISL32437EIBZ-T7A	32437 EIBZ	-40 to +85	250	8 Ld SOIC	M8.15
ISL32437EIUZ	2437E	-40 to +85	-	8 Ld MSOP	M8.118
ISL32437EIUZ-T	2437E	-40 to +85	2.5k	8 Ld MSOP	M8.118
ISL32437EIUZ-T7A	2437E	-40 to +85	250	8 Ld MSOP	M8.118

NOTES:

1. See [TB347](#) for details about reel specifications.
2. These Pb-free plastic packaged products employ special Pb-free material sets, molding compounds/die attach materials, and 100% matte tin plate plus anneal (e3 termination finish, which is RoHS compliant and compatible with both SnPb and Pb-free soldering operations). Pb-free products are MSL classified at Pb-free peak reflow temperatures that meet or exceed the Pb-free requirements of IPC/JEDEC J STD-020.
3. For Moisture Sensitivity Level (MSL), see the [ISL32430E](#), [ISL32432E](#), [ISL32433E](#), [ISL32435E](#), [ISL32437E](#) device pages. For more information about MSL, see [TB363](#).

TABLE 1. SUMMARY OF FEATURES

PART NUMBER	HALF/FULL DUPLEX	DATA RATE (Mbps)	SLEW-RATE LIMITED?	EN PINS?	HOT PLUG	CABLE INVERT (INV) PIN?	QUIESCENT I _{CC} (mA)	LOW POWER SHUTDOWN?	PIN COUNT
ISL32430E	Full	0.25	Yes	Yes	No	No	2.1	Yes	10, 14
ISL32432E	Half	0.25	Yes	Yes	No	No	2.1	Yes	8
ISL32433E	Full	1	Yes	Yes	No	No	2.1	Yes	10, 14
ISL32435E	Half	1	Yes	Yes	No	No	2.1	Yes	8
ISL32437E	Half	0.25	Yes	Tx Only	No	Yes	2.1	No	8

Pin Configurations

ISL32430E, ISL32433E
(14 LD SOIC)
TOP VIEW

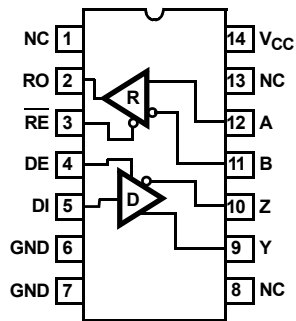

ISL32430E, ISL32433E
(10 LD MSOP)
TOP VIEW

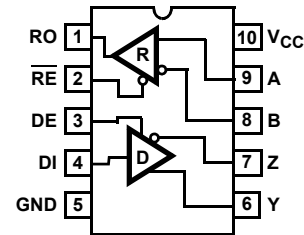

ISL32432E, ISL32435E
(8 LD SOIC, 8 LD MSOP)
TOP VIEW

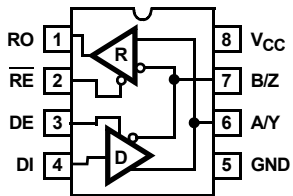

ISL32437E
(8 LD SOIC, 8 LD MSOP)
TOP VIEW

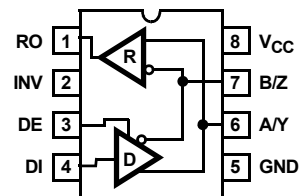

Pin Descriptions

PIN NAME	PIN NUMBER					FUNCTION
	ISL32430E, ISL32433E, 14 LD SOIC	ISL32430E, ISL32433E, 10 LD MSOP	ISL32432E, ISL32435E	ISL32437E		
RO	2	1	1	1		Receiver output. For parts without the cable invert function, or if INV is low, then: If $A - B \geq -10\text{mV}$, RO is high; if $A - B \leq -200\text{mV}$, RO is low. If INV is high, then: If $B - A \geq -10\text{mV}$, RO is high; if $B - A \leq -200\text{mV}$, RO is low. In all cases, RO = High if A and B are unconnected (floating), or shorted together, or connected to an undriven, terminated bus (For example, Rx is always fail-safe open, shorted, and idle, even if polarity is inverted).
$\overline{\text{RE}}$	3	2	2	N/A		Receiver output enable. RO is enabled when $\overline{\text{RE}}$ is low; RO is high impedance when $\overline{\text{RE}}$ is high. Internally pulled low.
DE	4	3	3	3		Driver output enable. The driver outputs, Y and Z, are enabled by bringing DE high, and they are high impedance when DE is low. Internally pulled high.
DI	5	4	4	4		Driver input. For parts without the cable invert function, or if INV is low, a low on DI forces output Y low and output Z high, while a high on DI forces output Y high and output Z low. The output states, relative to DI, invert if INV is high.

Pin Descriptions (Continued)

PIN NAME	PIN NUMBER				FUNCTION
	ISL32430E, ISL32433E, 14 LD SOIC	ISL32430E, ISL32433E, 10 LD MSOP	ISL32432E, ISL32435E	ISL32437E	
GND	6, 7	5	5	5	Ground connection.
A/Y	N/A	N/A	6	6	±40V Fault Protected and ±15kV ESD protected RS-485/RS-422 I/O pin. For parts without the cable invert function, or if INV is low, A/Y is the non-inverting receiver input and non-inverting driver output. If INV is high, A/Y is the inverting receiver input and the inverting driver output. Pin is an input if DE = 0; pin is an output if DE = 1.
B/Z	N/A	N/A	7	7	±40V Fault Protected and ±15kV ESD protected RS-485/RS-422 I/O pin. For parts without the cable invert function, or if INV is low, B/Z is the inverting receiver input and inverting driver output. If INV is high, B/Z is the non-inverting receiver input and the non-inverting driver output. Pin is an input if DE = 0; pin is an output if DE = 1.
A	12	9	N/A	N/A	±40V Fault Protected and ±15kV ESD protected RS-485/RS-422 non-inverting receiver input.
B	11	8	N/A	N/A	±40V Fault Protected and ±15kV ESD protected RS-485/RS-422 inverting receiver input.
Y	9	6	N/A	N/A	±40V Fault Protected and ±15kV ESD protected RS-485/RS-422 non-inverting driver output.
Z	10	7	N/A	N/A	±40V Fault Protected and ±15kV ESD protected RS-485/RS-422 inverting driver output.
V _{CC}	14	10	8	8	System power supply input (3V to 5.5V).
INV	N/A	N/A	N/A	2	Receiver and driver Cable Invert (polarity selection) input. When driven high, this pin swaps the polarity of the driver output and receiver input pins. If unconnected (floating) or connected low, normal RS-485 polarity conventions apply. Internally pulled low.
NC	1, 8, 13	N/A	N/A	N/A	No Internal Connection.

Truth Tables

TRANSMITTING					
INPUTS				OUTPUTS	
\overline{RE}	DE	DI	INV (Note 4)	Y	Z
X	1	1	0	1	0
X	1	0	0	0	1
X	1	1	1	0	1
X	1	0	1	1	0
0	0	X	X	High-Z	High-Z
1	0	X	X	High-Z*	High-Z*

NOTES:

4. Parts without the INV pin follow the rows with INV = "0" and "X".
 *Low Power Shutdown Mode (See [Notes 13](#) and [18](#)).

RECEIVING					
INPUTS					OUTPUT
\overline{RE} (Note 18)	DE (Half Duplex)	DE (Full Duplex)	A-B	INV (Note 4)	RO
0	0	X	$\geq -0.01V$	0	1
0	0	X	$\leq -0.2V$	0	0
0	0	X	$\leq 0.01V$	1	1
0	0	X	$\geq 0.2V$	1	0
0	0	X	Inputs Open or Shorted	X	1
1	0	0	X	X	High-Z*
1	1	1	X	X	High-Z

NOTE: *Low Power Shutdown Mode (See [Notes 13](#) and [18](#)).

Absolute Maximum Ratings

V _{CC} to Ground	7V
Input Voltages	
DI, DE, \overline{RE} , INV	-0.3V to V _{CC} + 0.3V
Input/Output Voltages	
A/Y, B/Z, A, B, Y, Z	±50V
A/Y, B/Z, A, B, Y, Z (Transient Pulse Through 100Ω, Note 5)	±60V
RO	-0.3V to (V _{CC} + 0.3V)
Short-Circuit Duration	
Y, Z	Indefinite
ESD Rating	see "ESD PERFORMANCE" on page 7
Latch-Up (per JESD78, Level 2, Class A)	+125°C

Thermal Information

Thermal Resistance (Typical)	θ_{JA} (°C/W)	θ_{JC} (°C/W)
8 Ld SOIC Package (Notes 6, 7)	108	47
8 Ld MSOP Package (Notes 6, 7)	140	40
10 Ld MSOP Package (Notes 6, 7)	135	50
14 Ld SOIC Package (Notes 6, 7)	88	39
Maximum Junction Temperature (Plastic Package)	+150°C	
Maximum Storage Temperature Range	-65°C to +150°C	
Pb-Free Reflow Profile	see TB493	

Recommended Operating Conditions

Supply Voltage (V _{CC})	3.3V or 5V
Temperature Range	-40°C to +85°C
Bus Pin Common-Mode Voltage Range	-15V to +15V

CAUTION: Do not operate at or near the maximum ratings listed for extended periods of time. Exposure to such conditions can adversely impact product reliability and result in failures not covered by warranty.

NOTES:

5. Tested according to TIA/EIA-485-A, Section 4.2.6 (±60V for 15μs at a 1% duty cycle).
6. θ_{JA} is measured with the component mounted on a high-effective thermal conductivity test board in free air. See [TB379](#) for details.
7. For θ_{JC} , the "case temp" location is taken at the package top center.

Electrical Specifications Test conditions: V_{CC} = 3V to 3.6V and 4.5V to 5.5V; unless otherwise specified. Typical values are at the worst case of V_{CC} = 5V or V_{CC} = 3.3V, T_A = +25°C ([Note 8](#)). **Boldface limits apply across the operating temperature range, -40°C to +85°C.**

PARAMETER	SYMBOL	TEST CONDITIONS	TEMP (°C)	MIN (Note 16)	TYP	MAX (Note 16)	UNIT	
DC CHARACTERISTICS								
Driver Differential V _{OUT} (No load)	V _{OD1}		Full	-	-	V _{CC}	V	
Driver Differential V _{OUT} (Loaded, Figure 6A)	V _{OD2}	R _L = 100Ω (RS-422), V _{CC} ≥ 4.5V	Full	2	3	-	V	
		R _L = 54Ω (RS-485)	V _{CC} ≥ 4.5V	Full	1.7	2.3	-	V
			V _{CC} = 3.3V	Full	1.35	1.42	-	V
			V _{CC} ≥ 3V	Full	1.1	1.3	-	V
Change in Magnitude of Driver Differential V _{OUT} for Complementary Output States	ΔV _{OD}	R _L = 54Ω or 100Ω (Figure 6A)	Full	-	-	0.2	V	
Driver Differential V _{OUT} with Common-Mode Load (Figure 6B)	V _{OD3}	R _L = 60Ω, -15V ≤ V _{CM} ≤ 15V, V _{CC} ≥ 4.5V	Full	1.5	-	-	V	
Driver Common-Mode V _{OUT} (Figure 6A)	V _{OC}	R _L = 54Ω or 100Ω	Full	-1	-	3	V	
Change in Magnitude of Driver Common-Mode V _{OUT} for Complementary Output States	ΔV _{OC}	R _L = 54Ω or 100Ω (Figure 6A)	Full	-	-	0.2	V	
Driver Short-Circuit Current	I _{OSD}	DE = V _{CC} , -15V ≤ V _O ≤ 15V (Note 10)	Full	-250	-	250	mA	
	I _{OSD1}	At first foldback, 24V ≤ V _O ≤ -24V	Full	-83	-	83	mA	
	I _{OSD2}	At second foldback, 35V ≤ V _O ≤ -35V	Full	-13	-	13	mA	
Logic Input High Voltage	V _{IH}	DE, DI, \overline{RE} , INV (See Figure 28)	Full	2.35	-	-	V	
Logic Input Low Voltage	V _{IL}	DE, DI, \overline{RE} , INV	Full	-	-	0.8	V	
Logic Input Current	I _{IN1}	DI	Full	-1	-	1	μA	
		DE, \overline{RE} , INV	Full	-15	6	15	μA	

Electrical Specifications Test conditions: $V_{CC} = 3V$ to $3.6V$ and $4.5V$ to $5.5V$; unless otherwise specified. Typical values are at the worst case of $V_{CC} = 5V$ or $V_{CC} = 3.3V$, $T_A = +25^\circ C$ (Note 8). **Boldface limits apply across the operating temperature range, $-40^\circ C$ to $+85^\circ C$.**

PARAMETER	SYMBOL	TEST CONDITIONS	TEMP ($^\circ C$)	MIN (Note 16)	TYP	MAX (Note 16)	UNIT	
Input/Output Current (A/Y, B/Z)	I_{IN2}	DE = 0V, $V_{CC} = 0V$ or 3.6V or 5.5V	$V_{IN} = 12V$	Full	-	-	250	μA
			$V_{IN} = -7V$	Full	-200	-	-	μA
			$V_{IN} = \pm 15V$	Full	-800	-	850	μA
			$V_{IN} = \pm 40V$, (Note 17)	Full	-6	-	6	mA
Input Current (A, B) (Full Duplex Versions Only)	I_{IN3}	$V_{CC} = 0V$ or 3.6V or 5.5V	$V_{IN} = 12V$	Full	-	-	125	μA
			$V_{IN} = -7V$	Full	-100	-	-	μA
			$V_{IN} = \pm 15V$	Full	-500	-	500	μA
			$V_{IN} = \pm 40V$, (Note 17)	Full	-3	-	3	mA
Output Leakage Current (Y, Z) (Full Duplex Versions Only)	I_{OZD}	$\overline{RE} = 0V$, DE = 0V, $V_{CC} = 0V$ or 3.6V or 5.5V	$V_{IN} = 12V$	Full	-	-	200	μA
			$V_{IN} = -7V$	Full	-100	-	-	μA
			$V_{IN} = \pm 15V$	Full	-500	-	500	μA
			$V_{IN} = \pm 40V$, (Note 17)	Full	-3	-	3	mA
Receiver Differential Threshold Voltage	V_{TH}	$-15V \leq V_{CM} \leq 15V$, (For ISL32437E only, A-B if INV = 0; B-A if INV = 1)	$V_{CC} \leq 3.6V$	Full	-200	-120	-10	mV
			$V_{CC} \geq 4.5V$	Full	-250	-180	-10	mV
Receiver Input Hysteresis	ΔV_{TH}	$-15V \leq V_{CM} \leq 15V$	+25	-	30	-	mV	
Receiver Output High Voltage	V_{OH1}	$V_{ID} = -10mV$	$I_O = -4mA$, $V_{CC} \geq 3V$	Full	2.4	-	-	V
	V_{OH2}		$I_O = -8mA$, $V_{CC} \geq 4.5V$	Full	2.4	-	-	V
Receiver Output Low Voltage	V_{OL}	$I_O = 4mA$, $V_{CC} \geq 3V$, $V_{ID} = -200mV$		Full	-	-	0.4	V
			$I_O = 5mA$, $V_{CC} \geq 4.5V$, $V_{ID} = -250mV$	Full	-	-	0.4	V
Three-State (High Impedance) Receiver Output Current (Note 18)	I_{OZR}	$0V \leq V_O \leq V_{CC}$	Full	-1	0.01	1	μA	
Receiver Short-Circuit Current	I_{OSR}	$0V \leq V_O \leq V_{CC}$	Full	-	-	± 115	mA	
SUPPLY CURRENT								
No-Load Supply Current (Note 9)	I_{CC}	DE = V_{CC} , $\overline{RE} = 0V$ or V_{CC} , DI = 0V or V_{CC}	Full	-	2.1	4.5	mA	
Shutdown Supply Current (Note 18)	I_{SHDN}	DE = 0V, $\overline{RE} = V_{CC}$, DI = 0V or V_{CC}	Full	-	10	35	μA	
ESD PERFORMANCE								
All Pins		Human Body Model (Tested per JESD22-A114E)	+25	-	± 8	-	kV	
		Machine Model (Tested per JESD22-A115-A)	+25	-	± 700	-	V	
RS-485 Pins (A, B, Y, Z, A/Y, B/Z)		Human Body Model, from Bus Pins to GND	Full Duplex	+25	-	± 15	-	kV
			Half Duplex	+25	-	± 16.5	-	kV
DRIVER SWITCHING CHARACTERISTICS (250kbps Versions; ISL32430E, ISL32432E, ISL32437E)								
Driver Differential Output Delay	t_{PLH}, t_{PHL}	$R_D = 54\Omega$, $C_D = 50pF$ (Figure 7)	Full	-	280	1000	ns	
Driver Differential Output Skew	t_{SKEW}	$R_D = 54\Omega$, $C_D = 50pF$ (Figure 7)	Full	-	4	100	ns	
Driver Differential Rise or Fall Time	t_R, t_F	$R_D = 54\Omega$, $C_D = 50pF$ (Figure 7)	Full	250	650	1500	ns	
Maximum Data Rate	f_{MAX}	$C_D = 820pF$ (Figure 9)	Full	250	-	-	kbps	
Driver Enable to Output High	t_{ZH}	SW = GND (Figure 8), (Note 11)	Full	-	-	1600	ns	
Driver Enable to Output Low	t_{ZL}	SW = V_{CC} (Figure 8), (Note 11)	Full	-	-	1600	ns	

Electrical Specifications Test conditions: $V_{CC} = 3V$ to $3.6V$ and $4.5V$ to $5.5V$; unless otherwise specified. Typical values are at the worst case of $V_{CC} = 5V$ or $V_{CC} = 3.3V$, $T_A = +25^\circ C$ (Note 8). **Boldface limits apply across the operating temperature range, $-40^\circ C$ to $+85^\circ C$.**

PARAMETER	SYMBOL	TEST CONDITIONS	TEMP ($^\circ C$)	MIN (Note 16)	TYP	MAX (Note 16)	UNIT
Driver Disable from Output Low	t_{LZ}	SW = V_{CC} (Figure 8)	Full	-	-	300	ns
Driver Disable from Output High	t_{HZ}	SW = GND (Figure 8)	Full	-	-	300	ns
Time to Shutdown	t_{SHDN}	(Notes 13, 18)	Full	60	160	600	ns
Driver Enable from Shutdown to Output High	$t_{ZH}(SHDN)$	SW = GND (Figure 8), (Notes 13, 14, 18)	Full	-	-	3000	ns
Driver Enable from Shutdown to Output Low	$t_{ZL}(SHDN)$	SW = V_{CC} (Figure 8), (Notes 13, 14, 18)	Full	-	-	3000	ns
DRIVER SWITCHING CHARACTERISTICS (1Mbps Versions; ISL32433E and ISL32435E)							
Driver Differential Output Delay	t_{PLH}, t_{PHL}	$R_D = 54\Omega$, $C_D = 50pF$ (Figure 7)	Full	-	70	200	ns
Driver Differential Output Skew	t_{SKEW}	$R_D = 54\Omega$, $C_D = 50pF$ (Figure 7)	Full	-	4	25	ns
Driver Differential Rise or Fall Time	t_R, t_F	$R_D = 54\Omega$, $C_D = 50pF$ (Figure 7)	Full	50	130	300	ns
Maximum Data Rate	f_{MAX}	$C_D = 820pF$ (Figure 9)	Full	1	-	-	Mbps
Driver Enable to Output High	t_{ZH}	SW = GND (Figure 8), (Note 11)	Full	-	-	300	ns
Driver Enable to Output Low	t_{ZL}	SW = V_{CC} (Figure 8), (Note 11)	Full	-	-	300	ns
Driver Disable from Output Low	t_{LZ}	SW = V_{CC} (Figure 8)	Full	-	-	300	ns
Driver Disable from Output High	t_{HZ}	SW = GND (Figure 8)	Full	-	-	300	ns
Time to Shutdown	t_{SHDN}	(Note 13)	Full	60	160	600	ns
Driver Enable from Shutdown to Output High	$t_{ZH}(SHDN)$	SW = GND (Figure 8), (Notes 13, 14)	Full	-	-	3000	ns
Driver Enable from Shutdown to Output Low	$t_{ZL}(SHDN)$	SW = V_{CC} (Figure 8), (Notes 13, 14)	Full	-	-	3000	ns
RECEIVER SWITCHING CHARACTERISTICS (250kbps Versions; ISL32430E, ISL32432E, ISL32437E)							
Maximum Data Rate	f_{MAX}	(Figure 10)	Full	250	-	-	kbps
Receiver Input to Output Delay	t_{PLH}, t_{PHL}	(Figure 10)	Full	-	240	325	ns
Receiver Skew $t_{PLH} - t_{PHL}$	t_{SKD}	(Figure 10)	Full	-	6	25	ns
Receiver Enable to Output Low	t_{ZL}	$R_L = 1k\Omega$, $C_L = 15pF$, SW = V_{CC} (Figure 11), (Notes 12, 18)	Full	-	-	80	ns
Receiver Enable to Output High	t_{ZH}	$R_L = 1k\Omega$, $C_L = 15pF$, SW = GND (Figure 11), (Notes 12, 18)	Full	-	-	80	ns
Receiver Disable from Output Low	t_{LZ}	$R_L = 1k\Omega$, $C_L = 15pF$, SW = V_{CC} (Figure 11), (Note 18)	Full	-	-	80	ns
Receiver Disable from Output High	t_{HZ}	$R_L = 1k\Omega$, $C_L = 15pF$, SW = GND (Figure 11), (Note 18)	Full	-	-	80	ns
Time to Shutdown	t_{SHDN}	(Notes 13, 18)	Full	60	160	600	ns
Receiver Enable from Shutdown to Output High	$t_{ZH}(SHDN)$	$R_L = 1k\Omega$, $C_L = 15pF$, SW = GND (Figure 11), (Notes 13, 15, 18)	Full	-	-	2500	ns
Receiver Enable from Shutdown to Output Low	$t_{ZL}(SHDN)$	$R_L = 1k\Omega$, $C_L = 15pF$, SW = V_{CC} (Figure 11), (Notes 13, 15, 18)	Full	-	-	2500	ns
RECEIVER SWITCHING CHARACTERISTICS (1Mbps Versions; ISL32433E, ISL32435E)							
Maximum Data Rate	f_{MAX}	(Figure 10)	Full	1	-	-	Mbps
Receiver Input to Output Delay	t_{PLH}, t_{PHL}	(Figure 10)	Full	-	115	200	ns
Receiver Skew $t_{PLH} - t_{PHL}$	t_{SKD}	(Figure 10)	Full	-	4	20	ns

Electrical Specifications Test conditions: $V_{CC} = 3V$ to $3.6V$ and $4.5V$ to $5.5V$; unless otherwise specified. Typical values are at the worst case of $V_{CC} = 5V$ or $V_{CC} = 3.3V$, $T_A = +25^\circ C$ (Note 8). **Boldface limits apply across the operating temperature range, $-40^\circ C$ to $+85^\circ C$.**

PARAMETER	SYMBOL	TEST CONDITIONS	TEMP (°C)	MIN (Note 16)	TYP	MAX (Note 16)	UNIT
Receiver Enable to Output Low	t_{ZL}	$R_L = 1k\Omega$, $C_L = 15pF$, $SW = V_{CC}$ (Figure 11), (Note 12)	Full	-	-	80	ns
Receiver Enable to Output High	t_{ZH}	$R_L = 1k\Omega$, $C_L = 15pF$, $SW = GND$ (Figure 11), (Note 12)	Full	-	-	80	ns
Receiver Disable from Output Low	t_{LZ}	$R_L = 1k\Omega$, $C_L = 15pF$, $SW = V_{CC}$ (Figure 11)	Full	-	-	80	ns
Receiver Disable from Output High	t_{HZ}	$R_L = 1k\Omega$, $C_L = 15pF$, $SW = GND$ (Figure 11)	Full	-	-	80	ns
Time to Shutdown	t_{SHDN}	(Note 13)	Full	60	160	600	ns
Receiver Enable from Shutdown to Output High	$t_{ZH}(SHDN)$	$R_L = 1k\Omega$, $C_L = 15pF$, $SW = GND$ (Figure 11), (Notes 13, 15)	Full	-	-	2500	ns
Receiver Enable from Shutdown to Output Low	$t_{ZL}(SHDN)$	$R_L = 1k\Omega$, $C_L = 15pF$, $SW = V_{CC}$ (Figure 11), (Notes 13, 15)	Full	-	-	2500	ns

NOTES:

8. All currents into device pins are positive; all currents out of device pins are negative. All voltages are referenced to device ground unless otherwise specified.
9. Supply current specification is valid for loaded drivers when $DE = 0V$.
10. Applies to peak current. See "Typical Performance Curves" beginning on page 11 for more information.
11. Keep $\overline{RE} = 0$ to prevent the device from entering SHDN (does not apply to the ISL32437E).
12. The \overline{RE} signal high time must be short enough (typically $<100ns$) to prevent the device from entering SHDN.
13. Transceivers are put into shutdown by bringing \overline{RE} high and DE low. If the inputs are in this state for less than $60ns$, the parts are ensured not to enter shutdown. If the inputs are in this state for at least $600ns$, the parts are ensured to enter shutdown see ("Low Power Shutdown Mode" on page 16).
14. Keep $\overline{RE} = V_{CC}$, and set the DE signal low time $>600ns$ to ensure that the device enters SHDN.
15. Set the \overline{RE} signal high time $>600ns$ to ensure that the device enters SHDN.
16. Compliance to data sheet limits is assured by one or more methods: production test, characterization and/or design.
17. See "Caution" statement below "Absolute Maximum Ratings" on page 6.
18. Does not apply to the ISL32437E. The ISL32437E has no Rx enable function, and thus no SHDN function.

Test Circuits and Waveforms

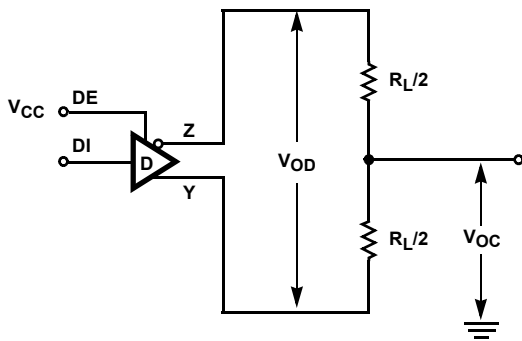

FIGURE 6A. V_{OD} AND V_{OC}

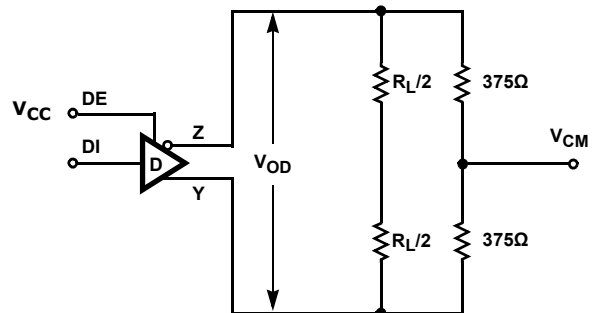

FIGURE 6B. V_{OD} WITH COMMON-MODE LOAD

FIGURE 6. DC DRIVER TEST CIRCUITS

Test Circuits and Waveforms (Continued)

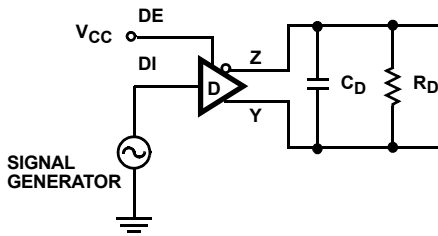

FIGURE 7A. TEST CIRCUIT

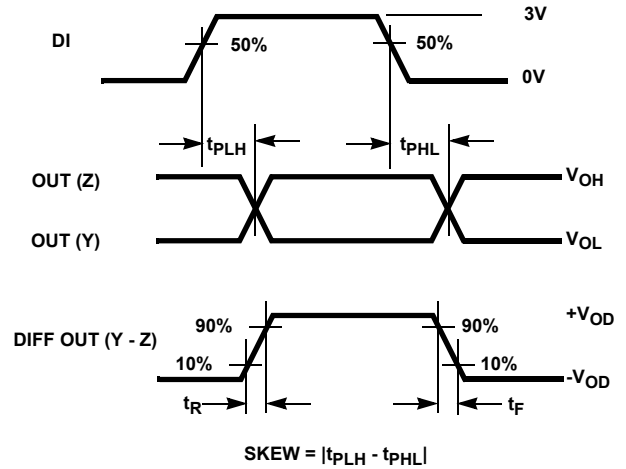
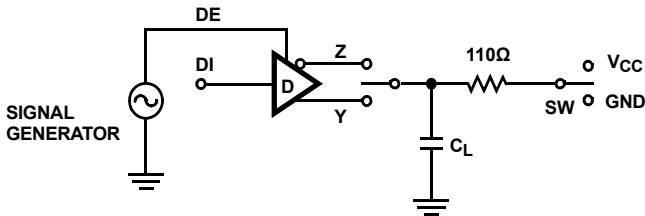

FIGURE 7B. MEASUREMENT POINTS

FIGURE 7. DRIVER PROPAGATION DELAY AND DIFFERENTIAL TRANSITION TIMES



PARAMETER	OUTPUT	RE	DI	SW	CL (pF)
t _{HZ}	Y/Z	X	1/0	GND	50
t _{LZ}	Y/Z	X	0/1	V _{CC}	50
t _{ZH}	Y/Z	0 (Note 11)	1/0	GND	100
t _{ZL}	Y/Z	0 (Note 11)	0/1	V _{CC}	100
t _{ZH(SHDN)}	Y/Z	1 (Note 14)	1/0	GND	100
t _{ZL(SHDN)}	Y/Z	1 (Note 14)	0/1	V _{CC}	100

FIGURE 8A. TEST CIRCUIT

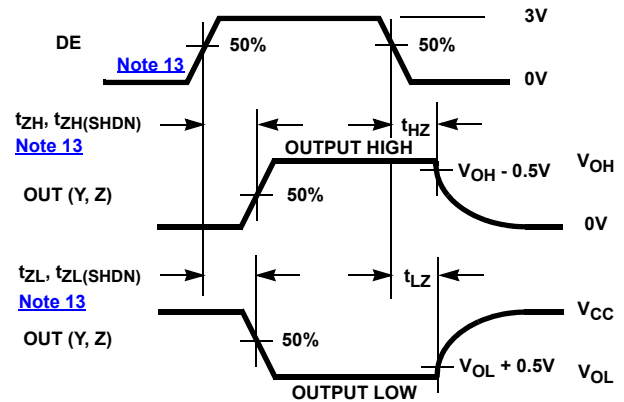

FIGURE 8B. MEASUREMENT POINTS

FIGURE 8. DRIVER ENABLE AND DISABLE TIMES

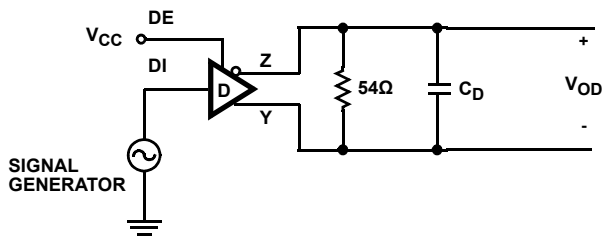

FIGURE 9A. TEST CIRCUIT

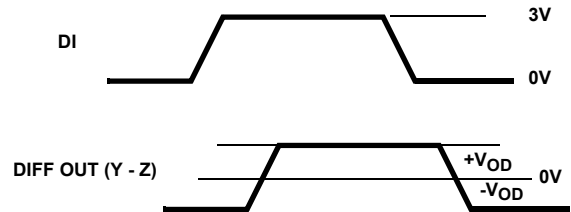

FIGURE 9B. MEASUREMENT POINTS

FIGURE 9. DRIVER DATA RATE

Test Circuits and Waveforms (Continued)

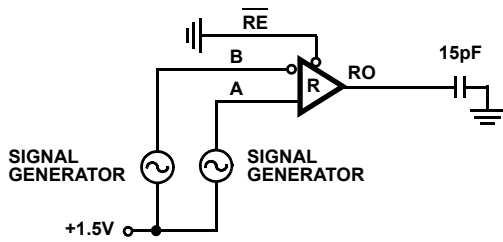

FIGURE 10A. TEST CIRCUIT

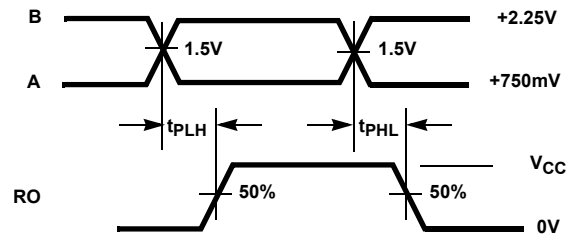
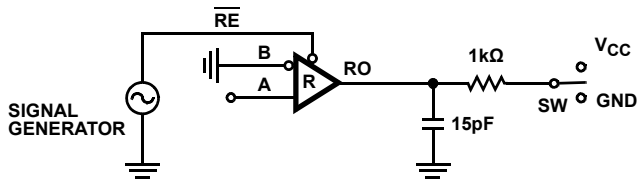

FIGURE 10B. MEASUREMENT POINTS

FIGURE 10. RECEIVER PROPAGATION DELAY AND DATA RATE



PARAMETER	DE	A	SW
t_{HZ}	0	+1.5V	GND
t_{LZ}	0	-1.5V	V_{CC}
t_{ZH} (Note 12)	0	+1.5V	GND
t_{ZL} (Note 12)	0	-1.5V	V_{CC}
$t_{ZH(SHDN)}$ (Note 15)	0	+1.5V	GND
$t_{ZL(SHDN)}$ (Note 15)	0	-1.5V	V_{CC}

FIGURE 11A. TEST CIRCUIT

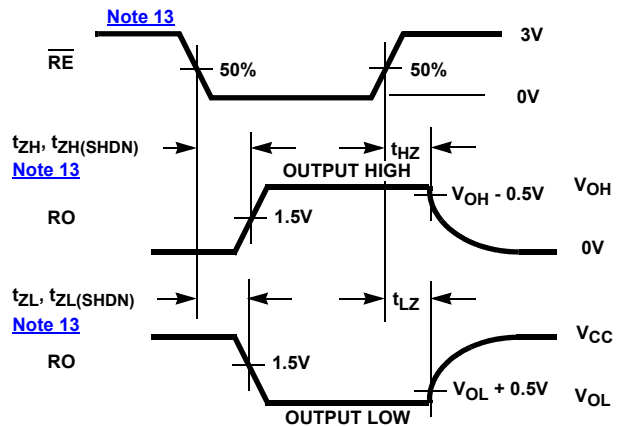

FIGURE 11B. MEASUREMENT POINTS

FIGURE 11. RECEIVER ENABLE AND DISABLE TIMES

Typical Performance Curves $T_A = +25^\circ\text{C}$; unless otherwise specified.

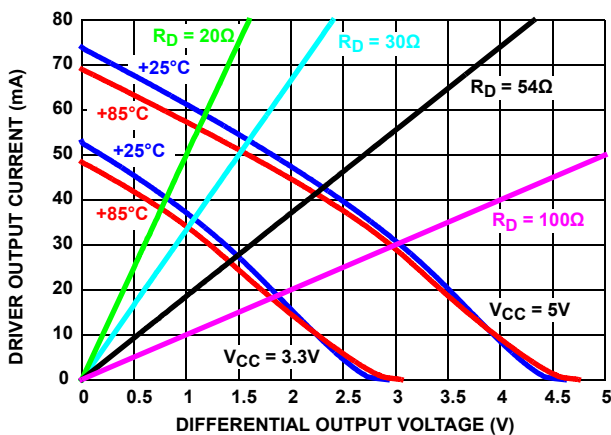

FIGURE 12. DRIVER OUTPUT CURRENT vs DIFFERENTIAL OUTPUT VOLTAGE

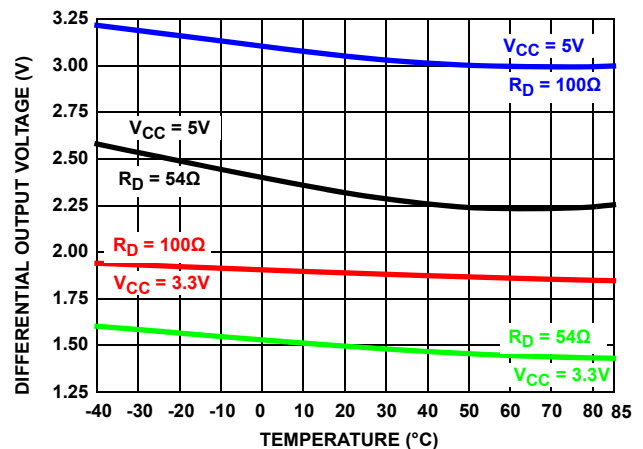

FIGURE 13. DRIVER DIFFERENTIAL OUTPUT VOLTAGE vs TEMPERATURE

Typical Performance Curves $T_A = +25^\circ\text{C}$; unless otherwise specified. (Continued)

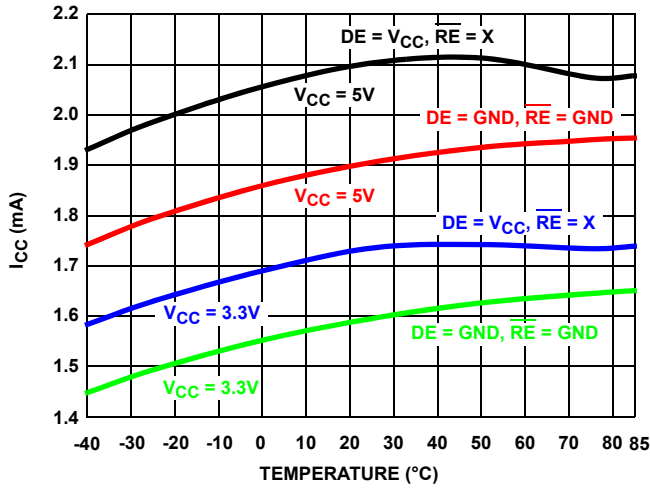

FIGURE 14. SUPPLY CURRENT vs TEMPERATURE

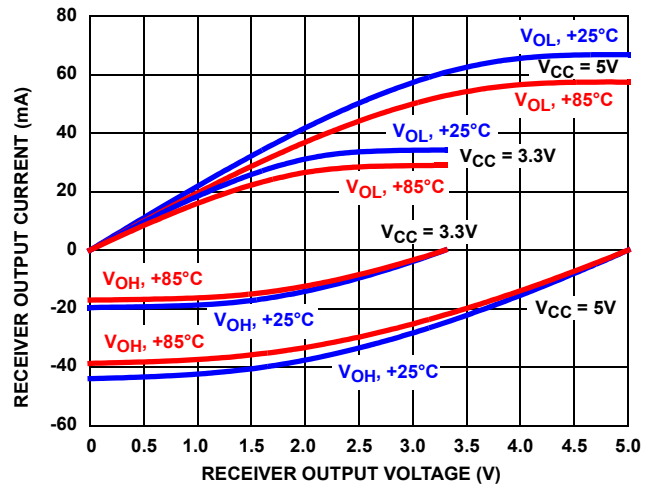

FIGURE 15. RECEIVER OUTPUT CURRENT vs RECEIVER OUTPUT VOLTAGE

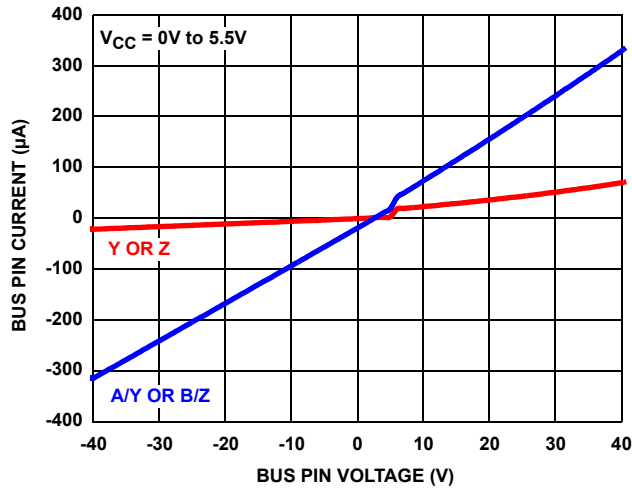

FIGURE 16. BUS PIN CURRENT vs BUS PIN VOLTAGE

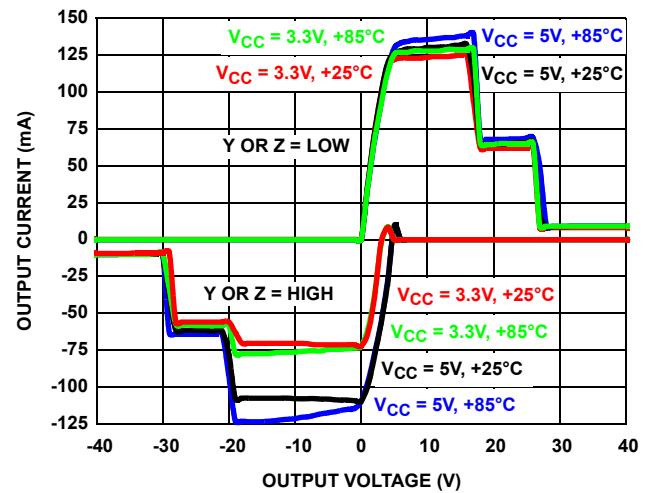

FIGURE 17. DRIVER OUTPUT CURRENT vs SHORT-CIRCUIT VOLTAGE

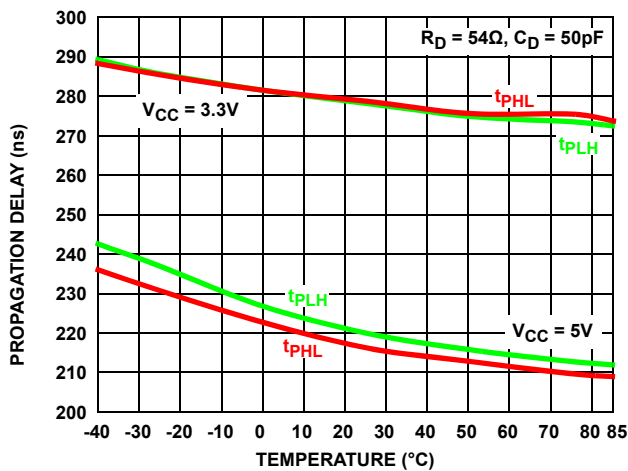

FIGURE 18. DRIVER DIFFERENTIAL PROPAGATION DELAY vs TEMPERATURE (ISL32430E, ISL32432E, ISL32437E)

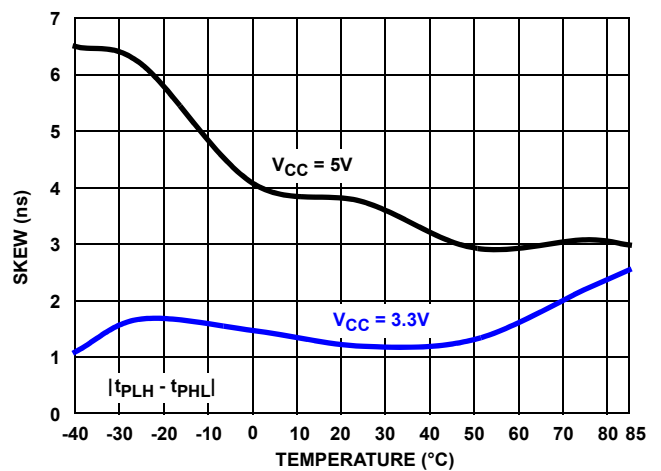

FIGURE 19. DRIVER DIFFERENTIAL SKEW vs TEMPERATURE (ISL32430E, ISL32432E, ISL32437E)

Typical Performance Curves $T_A = +25^\circ\text{C}$; unless otherwise specified. (Continued)

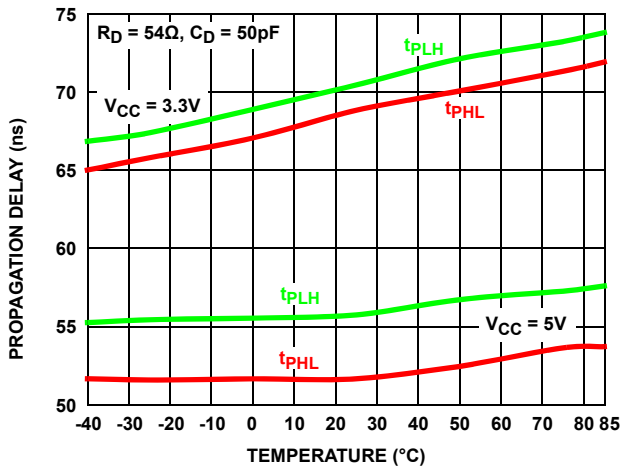

FIGURE 20. DRIVER DIFFERENTIAL PROPAGATION DELAY vs TEMPERATURE (ISL32433E, ISL32435E)

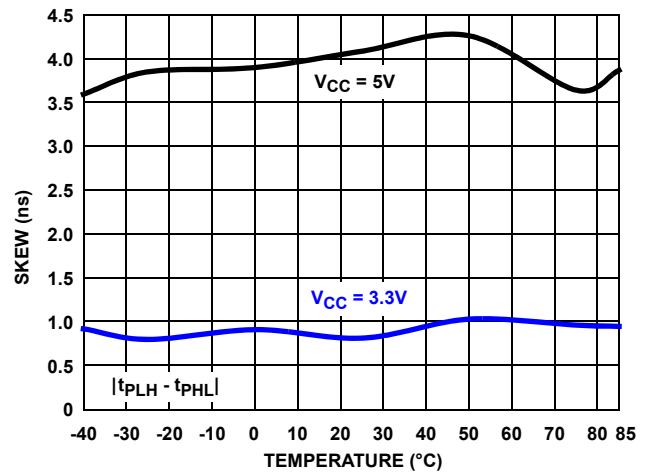

FIGURE 21. DRIVER DIFFERENTIAL SKEW vs TEMPERATURE (ISL32433E, ISL32435E)

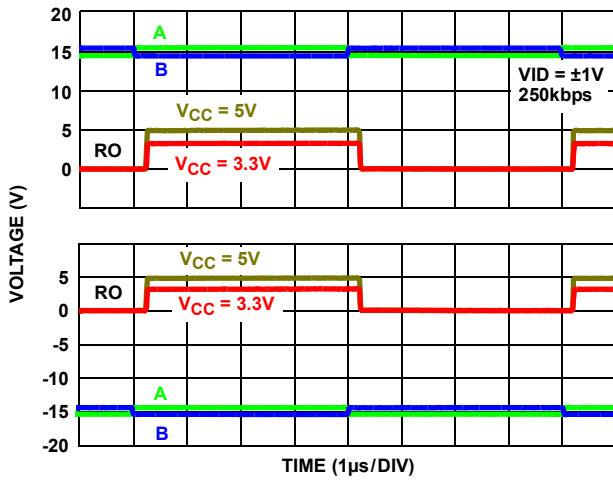

FIGURE 22. $\pm 15\text{V}$ RECEIVER PERFORMANCE (ISL32430E, ISL32432E, ISL32437E)

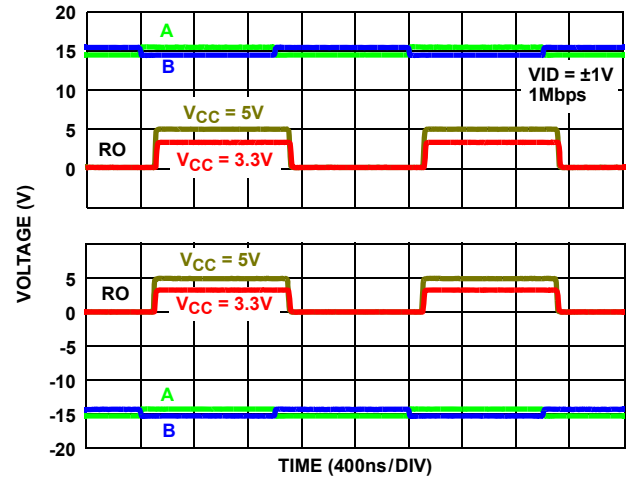

FIGURE 23. $\pm 15\text{V}$ RECEIVER PERFORMANCE (ISL32433E, ISL32435E)

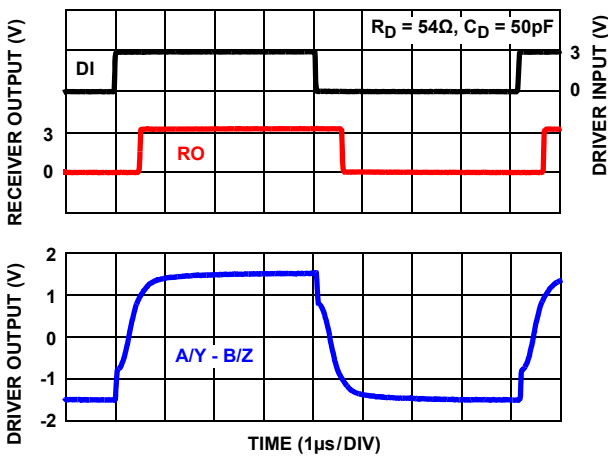

FIGURE 24. $V_{CC} = 3.3\text{V}$, DRIVER AND RECEIVER WAVEFORMS (ISL32430E, ISL32432E, ISL32437E)

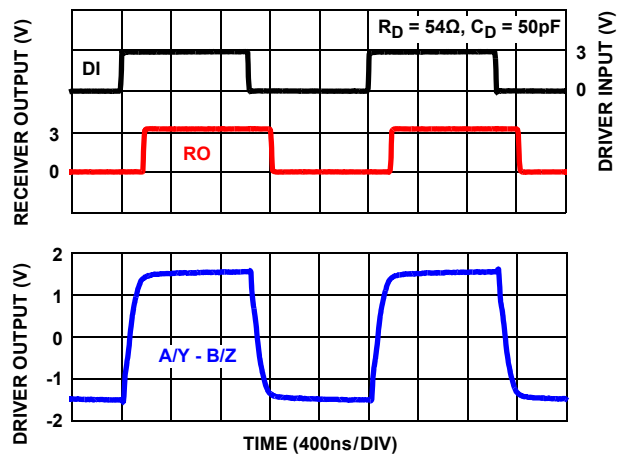

FIGURE 25. $V_{CC} = 3.3\text{V}$, DRIVER AND RECEIVER WAVEFORMS (ISL32433E, ISL32435E)

Typical Performance Curves $T_A = +25^\circ\text{C}$; unless otherwise specified. (Continued)

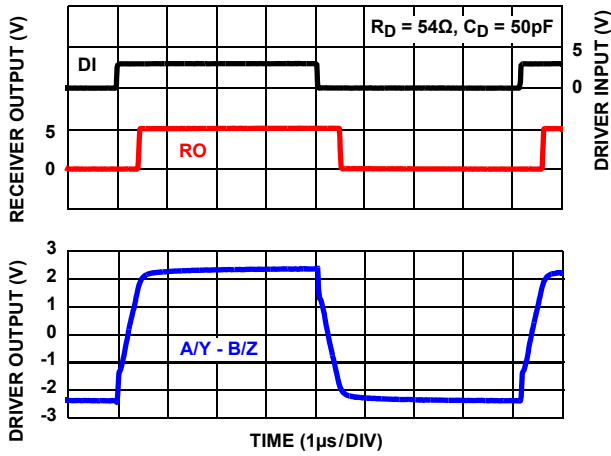

FIGURE 26. $V_{CC} = 5\text{V}$, DRIVER AND RECEIVER WAVEFORMS (ISL32430E, ISL32432E, ISL32437E)

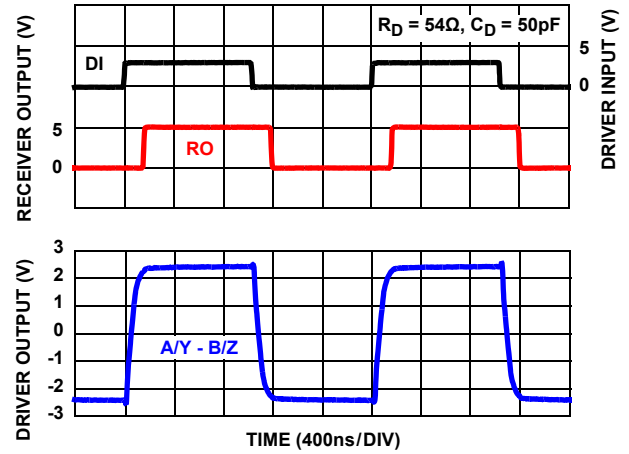

FIGURE 27. $V_{CC} = 5\text{V}$, DRIVER AND RECEIVER WAVEFORMS (ISL32433E, ISL32435E)

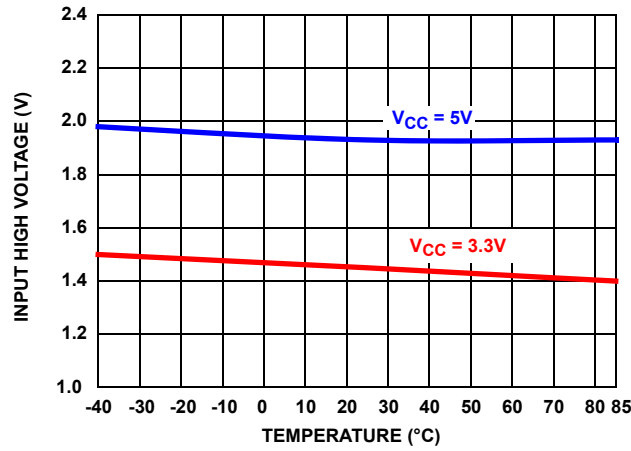

FIGURE 28. LOGIC INPUT HIGH VOLTAGE vs TEMPERATURE

Application Information

RS-485 and RS-422 are differential (balanced) data transmission standards used for long haul or noisy environments. RS-422 is a subset of RS-485, so RS-485 transceivers are also RS-422 compliant. RS-422 is a point-to-multipoint (multidrop) standard that allows only one driver and up to 10 receivers (assuming one-unit load devices) on each bus. RS-485 is a true multipoint standard that allows up to 32 one unit load devices (any combination of drivers and receivers) on each bus. To allow for multipoint operation, the RS-485 specification requires that drivers must handle bus contention without sustaining any damage.

An important advantage of RS-485 is the extended Common-Mode Range (CMR) that specifies that the driver outputs and receiver inputs withstand signals that range from +12V to -7V. RS-422 and RS-485 are intended for runs as long as 4000ft, so the wide CMR is necessary to handle ground potential differences and voltages induced in the cable by external fields.

A family of ruggedized RS-485 transceivers, the ISL3243xE devices improve on the RS-485 basic requirements and increase system reliability. The CMR increases to $\pm 15V$ and the RS-485 bus pins (receiver inputs and driver outputs) include fault protection against voltages and transients up to $\pm 40V$. Additionally, the $\pm 15kV$ to $\pm 16.5kV$ built-in ESD protection complements the fault protection.

Receiver (Rx) Features

The ISL3243xE devices use a differential input receiver for maximum noise immunity and common-mode rejection. Input sensitivity is better than $\pm 200mV$ (3.3V operation) as required by the RS-422 and RS-485 specifications.

The receiver input (load) current surpasses the RS-422 specification of 3mA and is four times lower than the RS-485 Unit Load (UL) requirement of 1mA maximum; therefore, these products are known as one-quarter UL transceivers. There can be up to 128 of these devices on a network while still complying with the RS-485 loading specification.

The receivers function with common-mode voltages as great as $\pm 15V$, so they are ideal for industrial or long networks where induced voltages are a realistic concern.

All the receivers include a full fail-safe function that ensures a high-level receiver output if the receiver inputs are unconnected (floating), shorted together, or connected to a terminated bus with all the transmitters disabled (an idle bus).

The receivers easily meet the data rates supported by the corresponding driver, and most receiver outputs are three-statable using the active low \overline{RE} input.

The Rx in the 250kbps (ISL32430E, ISL32432E, and ISL32437E) and 1Mbps versions (ISL32433E and ISL32435E) include noise filtering circuitry to reject high-frequency signals. The ISL32433E and ISL32435 typically reject pulses narrower than 50ns (equivalent to 20Mbps). The ISL32430E, ISL32432E, and ISL32437E Rx reject pulses below 150ns (6.7Mbps).

Driver (Tx) Features

The RS-485 and RS-422 drivers are differential output devices that deliver at least 1.7V across a 54Ω load (RS-485), and at least 2V across a 100Ω load (RS-422) with $V_{CC} \geq 4.5V$. The drivers feature low propagation delay skew to maximize bit width, and to minimize EMI. All drivers are three-statable using the active high DE input.

The 250kbps and 1Mbps driver outputs are slew rate limited to minimize EMI and reflections in unterminated or improperly terminated networks.

High Overvoltage (Fault) Protection Increases Ruggedness

The $\pm 40V$ fault protection (referenced to the IC GND) on the RS-485 pins makes these transceivers some of the most rugged on the market. This level of protection makes the ISL3243xE family perfect for applications where power (such as 24V supplies) must be routed in the conduit with the data lines or for outdoor applications where large transients are likely to occur. When power is routed with the data lines, even a momentary short between the supply and data lines destroys an unprotected device. The $\pm 40V$ fault levels of this family are at least three times higher than the levels specified for standard RS-485 ICs. The ISL3243xE's protection is active whether the Tx is enabled or disabled, and even if the IC is powered down or VCC and Ground are floating.

If transients or voltages (including overshoots and ringing) greater than $\pm 50V$ are possible, additional external protection is required. Use a protection device with the lowest clamping voltage acceptable for the application, and note, TVS type devices typically clamp 5V to 10V above the designated stand-off voltage (such as a "45V TVS" clamps between 50V and 55V).

Wide Common-Mode Voltage (CMV) Tolerance Improves Operating Range

RS-485 networks, operating in industrial complexes or over long distances, are susceptible to large CMV variations. Either of these operating environments can suffer from large node-to-node ground potential differences or CMV pickup from external electromagnetic sources; devices with only the minimum required +12V to -7V CMR can malfunction. The ISL3243xE's extended $\pm 15V$ CMR allows for operation in environments that would overwhelm lesser transceivers. Additionally, the Rx does not phase invert (erroneously change state) even with CMVs of $\pm 20V$ or differential voltages as large as 40V.

Cable Invert (Polarity Reversal) Function

Large node count RS-485 networks are commonly wired backwards during installation. When this happens, the node is unable to communicate over the network. When technicians find the miswired node, they must rewire the connector, which is time consuming.

The ISL32437E simplifies this task by including a cable invert pin (INV) that allows the technician to invert the polarity of the Rx input and the Tx output pins simply by moving a jumper to change the state of the invert pin. When the invert pin is low, the IC operates like any standard RS-485 transceiver, and the bus pins have their normal polarity definition of A and Y being noninverting and B and Z being inverting. With the invert pin high, the corresponding bus pins reverse their polarity, so B and Z are now noninverting while A and Y become inverting.

This unique cable invert function is superior to that found on competing devices, because the Rx full fail-safe function is maintained even when the Rx polarity is reversed. Competitor devices implement the Rx invert function simply by inverting the Rx output. Therefore, with the Rx inputs floating or shorted together, the Rx appropriately delivers a logic 1 in normal polarity but outputs a logic low when the IC is operated in the inverted mode. The innovative Renesas Rx design ensures that the Rx output remains high with the Rx inputs floating or shorted together ($V_{ID} = 0V$), regardless of the state of the invert pin.

Data Rate, Cables, and Terminations

RS-485/RS-422 are intended for network lengths up to 4000ft, but the maximum system data rate decreases as the transmission length increases. The ISL32433E and ISL32435E can operate at full data rates of 1Mbps with lengths up to 800ft (244m). Jitter is the limiting parameter at this faster data rate, so employing encoded data streams (such as Manchester coded or Return-to-Zero) can allow increased transmission distances. The ISL32430E, ISL32432E, and ISL32437E can operate at 115kbps or less at the full 4000ft (1220m) distance or at 250kbps for lengths up to 3000ft (915m). DC cable attenuation is the limiting parameter, so using better quality cables (such as 22 AWG) can allow increased transmission distance.

Use a twisted pair cable for RS-485/RS-422 networks. Twisted pair cables tend to pick up noise and other electromagnetically induced voltages as common-mode signals that are effectively rejected by the differential receivers in these ICs.

Short networks using the ISL32430E, ISL32432E, and ISL32437E do not need to be terminated; however, terminations are recommended unless power dissipation is an overriding concern.

In point-to-point or point-to-multipoint networks (single driver on bus like RS-422), terminate the main cable in its characteristic impedance (typically 120 Ω) at the end farthest from the driver. In multi-receiver applications, keep stubs connecting receivers to the main cable as short as possible. Multipoint (multi-driver) systems require that the main cable is terminated in its characteristic impedance at both ends. Keep stubs connecting a transceiver to the main cable as short as possible.

Built-In Driver Overload Protection

The RS-485 specification requires that drivers survive worst case bus contentions undamaged. These transceivers meet this requirement using driver output short-circuit current limits and on-chip thermal shutdown circuitry.

The driver output stages incorporate a double fold-back short-circuit current limiting scheme ensuring that the output current never exceeds the RS-485 specification even at the common-mode and fault-condition voltage range extremes. The first foldback current level ($\approx 83mA$) is set to ensure that the driver never folds back when driving loads with common-mode voltages up to $\pm 15V$. The very low, second foldback current setting ($\approx 13mA$) minimizes power dissipation if the Tx is enabled when a fault occurs.

In the event of a major short-circuit condition, The ISL3243xE's thermal shutdown feature disables the drivers whenever the die temperature becomes excessive. Thermal shutdown eliminates the power dissipation allowing the die to cool. The drivers automatically re-enable after the die temperature drops about $+15^{\circ}C$. If the contention persists, the thermal shutdown/re-enable cycle repeats until the fault is cleared. The receivers stay operational during thermal shutdown.

Low Power Shutdown Mode

These BiCMOS transceivers all use a fraction of the power required by competitive devices, but they (excluding ISL32437E) also include a shutdown feature that reduces the already low quiescent I_{CC} to a 10 μA trickle. The ISL3243xE family enter shutdown whenever the receiver and driver are simultaneously disabled ($RE = V_{CC}$ and $DE = GND$) for a period of at least 600ns. Disabling both the driver and the receiver for less than 60ns ensures that the transceiver does not enter shutdown.

Note that receiver and driver enable times increase when the transceiver enables from shutdown. See [Notes 11](#) through [15](#) on [page 9](#) for more information.

Die Characteristics

SUBSTRATE POTENTIAL (POWERED UP):

GND

PROCESS:

Si Gate BiCMOS

Revision History

The revision history provided is for informational purposes only and is believed to be accurate, but not warranted. Please go to web to make sure you have the latest Rev.

DATE	REVISION	CHANGE
Feb 15, 2019	FN7920.1	Updated links throughout document. Updated Related Literature section. Updated ordering information table by adding all tape and reel information and updating notes. Updated last sentence in first paragraph in "High Overvoltage (Fault) Protection Increases Ruggedness" on page 15. Removed Products section. Updated disclaimer.
Mar 1, 2012	FN7920.0	Initial Release

Package Outline Drawings

For the most recent package outline drawing, see [M8.118](#).

M8.118

8 LEAD MINI SMALL OUTLINE PLASTIC PACKAGE

Rev 4, 7/11

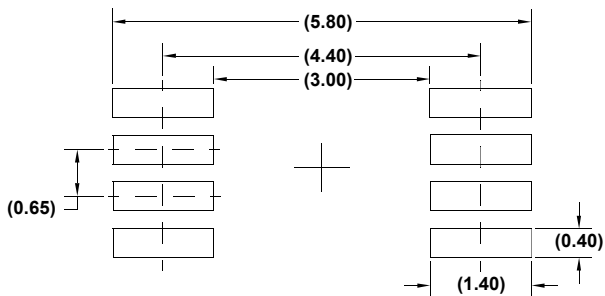
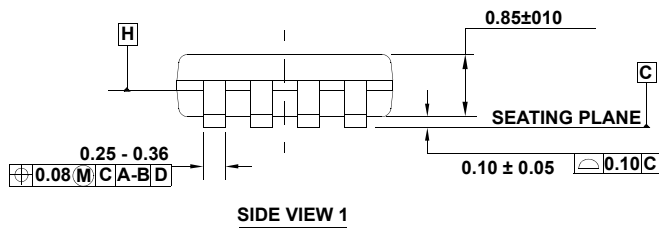
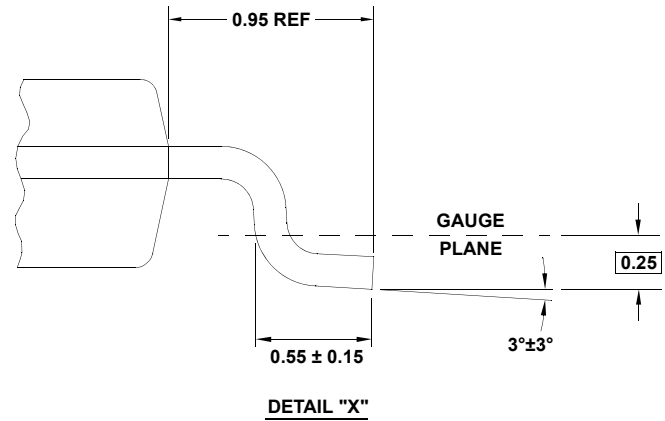
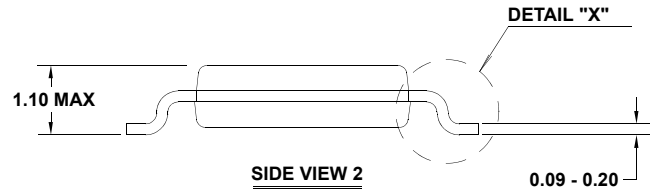
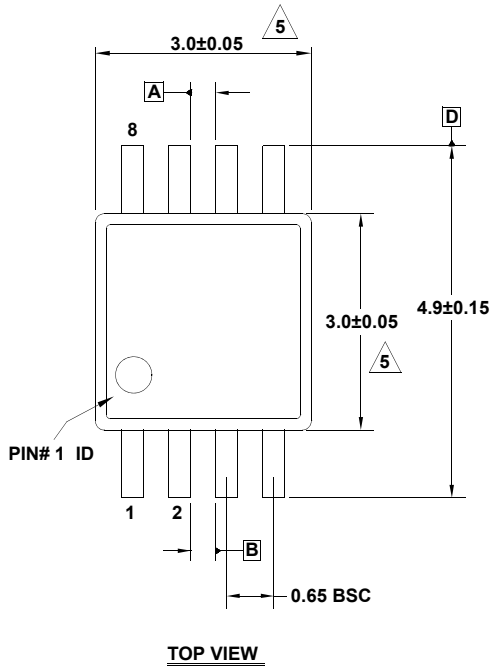

NOTES:

1. Dimensions are in millimeters.
2. Dimensioning and tolerancing conform to JEDEC MO-187-AA and AMSEY14.5m-1994.
3. Plastic or metal protrusions of 0.15mm max per side are not included.
4. Plastic interlead protrusions of 0.15mm max per side are not included.

5. Dimensions are measured at Datum Plane "H".

6. Dimensions in () are for reference only.

M8.15

8 LEAD NARROW BODY SMALL OUTLINE PLASTIC PACKAGE

Rev 4, 1/12

For the most recent package outline drawing, see [M8.15](#).

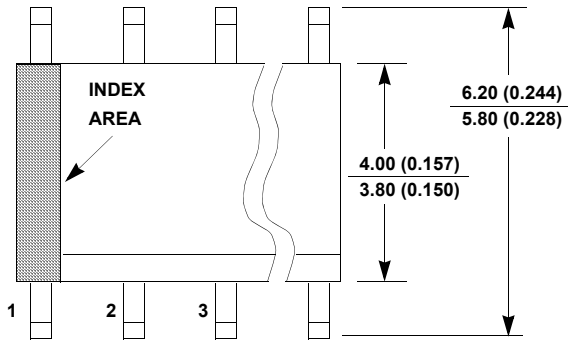

TOP VIEW

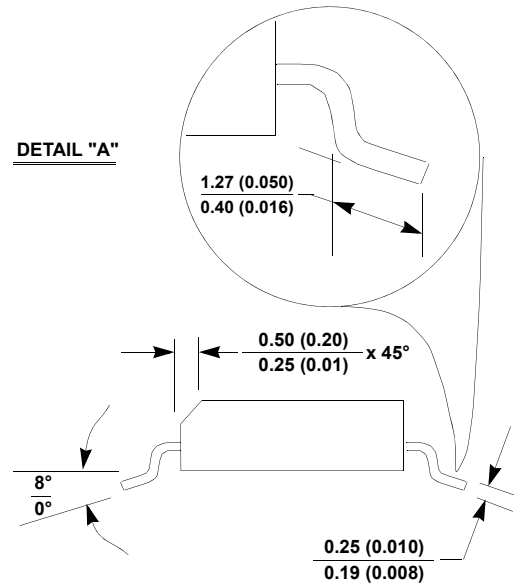

SIDE VIEW "B"

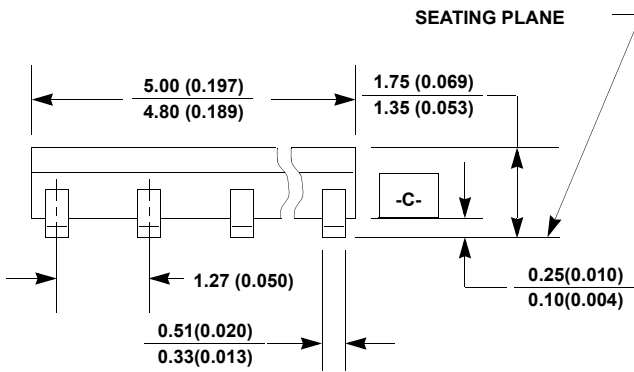

SIDE VIEW "A"

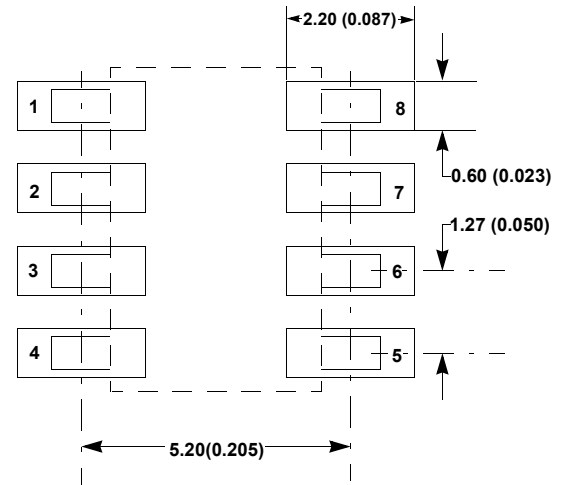

TYPICAL RECOMMENDED LAND PATTERN

NOTES:

19. Dimensioning and tolerancing per ANSI Y14.5M-1994.
20. Package length does not include mold flash, protrusions or gate burrs. Mold flash, protrusion and gate burrs shall not exceed 0.15mm (0.006 inch) per side.
21. Package width does not include interlead flash or protrusions. Interlead flash and protrusions shall not exceed 0.25mm (0.010 inch) per side.
22. The chamfer on the body is optional. If it is not present, a visual index feature must be located within the crosshatched area.
23. Terminal numbers are shown for reference only.
24. The lead width as measured 0.36mm (0.014 inch) or greater above the seating plane, shall not exceed a maximum value of 0.61mm (0.024 inch).
25. Controlling dimension: MILLIMETER. Converted inch dimensions are not necessarily exact.
26. This outline conforms to JEDEC publication MS-012-AA ISSUE C.

M10.118

10 LEAD MINI SMALL OUTLINE PLASTIC PACKAGE

Rev 1, 4/12

For the most recent package outline drawing, see [M10.118](#).

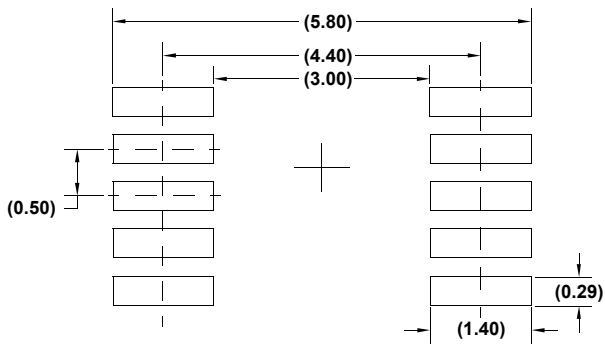
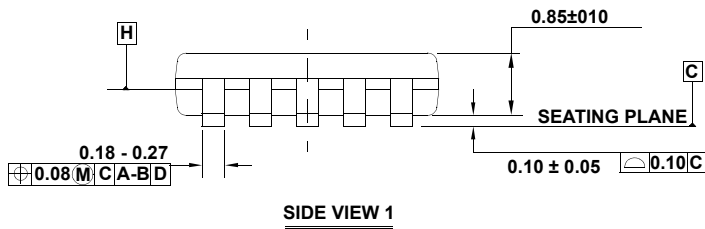
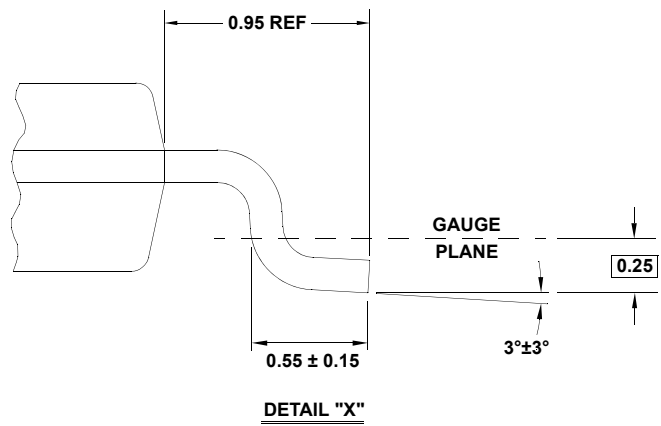
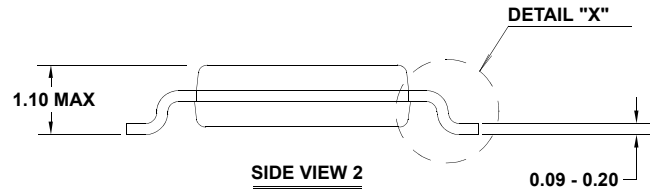
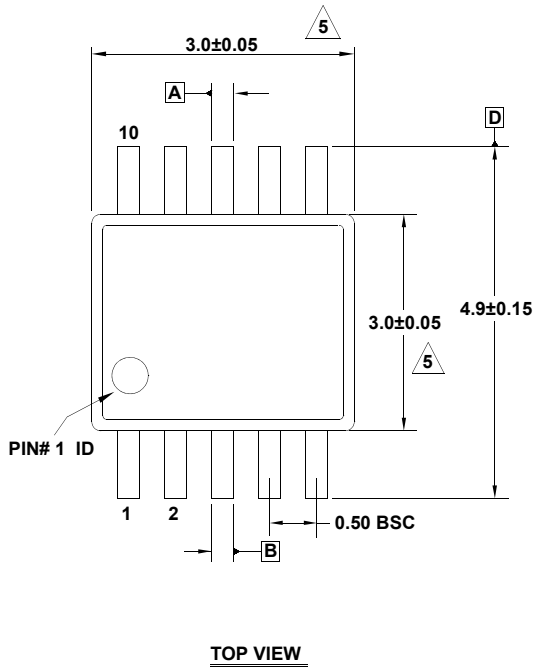

NOTES:

1. Dimensions are in millimeters.
2. Dimensioning and tolerancing conform to JEDEC MO-187-BA and AMSEY14.5m-1994.
3. Plastic or metal protrusions of 0.15mm max per side are not included.
4. Plastic interlead protrusions of 0.15mm max per side are not included.
5. Dimensions are measured at Datum Plane "H".
6. Dimensions in () are for reference only.

M14.15

14 LEAD NARROW BODY SMALL OUTLINE PLASTIC PACKAGE

Rev 1, 10/09

For the most recent package outline drawing, see [M14.15](#).

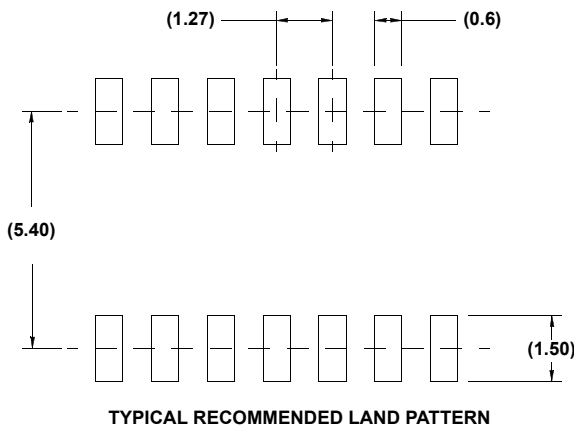
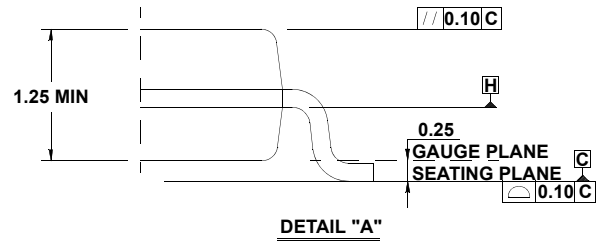
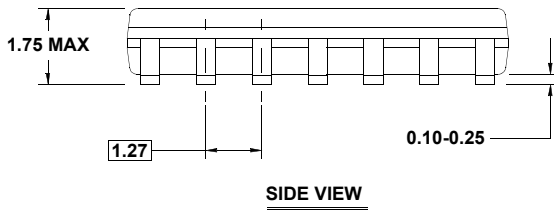
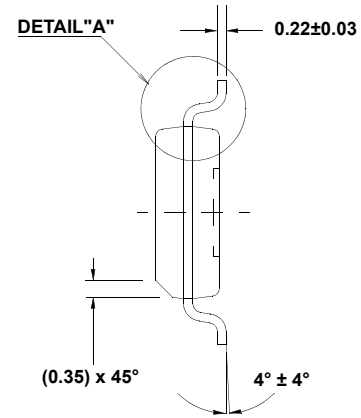
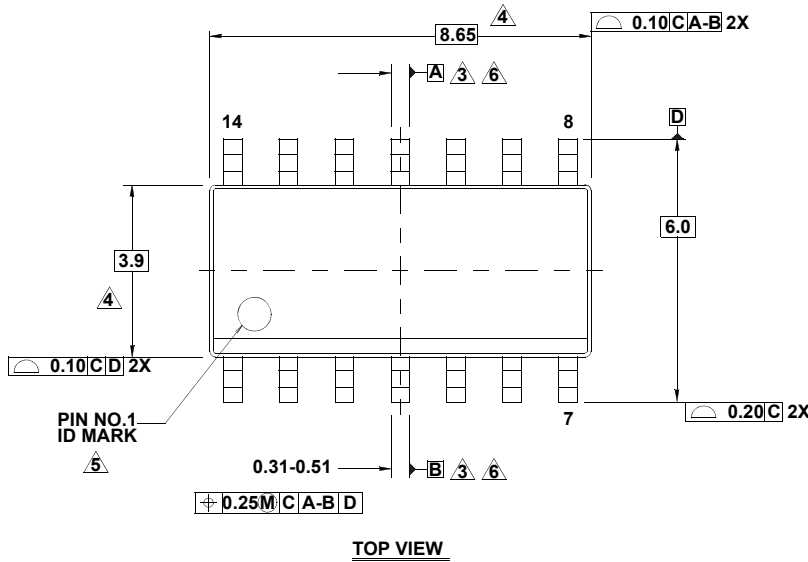

NOTES:

1. Dimensions are in millimeters.
Dimensions in () for Reference Only.
2. Dimensioning and tolerancing conform to AMSEY14.5m-1994.
3. Datums A and B to be determined at Datum H.
4. Dimension does not include interlead flash or protrusions.
Interlead flash or protrusions shall not exceed 0.25mm per side.
5. The pin #1 identifier may be either a mold or mark feature.
6. Does not include dambar protrusion. Allowable dambar protrusion shall be 0.10mm total in excess of lead width at maximum condition.
7. Reference to JEDEC MS-012-AB.

Notice

1. Descriptions of circuits, software and other related information in this document are provided only to illustrate the operation of semiconductor products and application examples. You are fully responsible for the incorporation or any other use of the circuits, software, and information in the design of your product or system. Renesas Electronics disclaims any and all liability for any losses and damages incurred by you or third parties arising from the use of these circuits, software, or information.
 2. Renesas Electronics hereby expressly disclaims any warranties against and liability for infringement or any other claims involving patents, copyrights, or other intellectual property rights of third parties, by or arising from the use of Renesas Electronics products or technical information described in this document, including but not limited to, the product data, drawings, charts, programs, algorithms, and application examples.
 3. No license, express, implied or otherwise, is granted hereby under any patents, copyrights or other intellectual property rights of Renesas Electronics or others.
 4. You shall not alter, modify, copy, or reverse engineer any Renesas Electronics product, whether in whole or in part. Renesas Electronics disclaims any and all liability for any losses or damages incurred by you or third parties arising from such alteration, modification, copying or reverse engineering.
 5. Renesas Electronics products are classified according to the following two quality grades: "Standard" and "High Quality". The intended applications for each Renesas Electronics product depends on the product's quality grade, as indicated below.
 - "Standard": Computers; office equipment; communications equipment; test and measurement equipment; audio and visual equipment; home electronic appliances; machine tools; personal electronic equipment; industrial robots; etc.
 - "High Quality": Transportation equipment (automobiles, trains, ships, etc.); traffic control (traffic lights); large-scale communication equipment; key financial terminal systems; safety control equipment; etc.Unless expressly designated as a high reliability product or a product for harsh environments in a Renesas Electronics data sheet or other Renesas Electronics document, Renesas Electronics products are not intended or authorized for use in products or systems that may pose a direct threat to human life or bodily injury (artificial life support devices or systems; surgical implantations; etc.), or may cause serious property damage (space system; undersea repeaters; nuclear power control systems; aircraft control systems; key plant systems; military equipment; etc.). Renesas Electronics disclaims any and all liability for any damages or losses incurred by you or any third parties arising from the use of any Renesas Electronics product that is inconsistent with any Renesas Electronics data sheet, user's manual or other Renesas Electronics document.
 6. When using Renesas Electronics products, refer to the latest product information (data sheets, user's manuals, application notes, "General Notes for Handling and Using Semiconductor Devices" in the reliability handbook, etc.), and ensure that usage conditions are within the ranges specified by Renesas Electronics with respect to maximum ratings, operating power supply voltage range, heat dissipation characteristics, installation, etc. Renesas Electronics disclaims any and all liability for any malfunctions, failure or accident arising out of the use of Renesas Electronics products outside of such specified ranges.
 7. Although Renesas Electronics endeavors to improve the quality and reliability of Renesas Electronics products, semiconductor products have specific characteristics, such as the occurrence of failure at a certain rate and malfunctions under certain use conditions. Unless designated as a high reliability product or a product for harsh environments in a Renesas Electronics data sheet or other Renesas Electronics document, Renesas Electronics products are not subject to radiation resistance design. You are responsible for implementing safety measures to guard against the possibility of bodily injury, injury or damage caused by fire, and/or danger to the public in the event of a failure or malfunction of Renesas Electronics products, such as safety design for hardware and software, including but not limited to redundancy, fire control and malfunction prevention, appropriate treatment for aging degradation or any other appropriate measures. Because the evaluation of microcomputer software alone is very difficult and impractical, you are responsible for evaluating the safety of the final products or systems manufactured by you.
 8. Please contact a Renesas Electronics sales office for details as to environmental matters such as the environmental compatibility of each Renesas Electronics product. You are responsible for carefully and sufficiently investigating applicable laws and regulations that regulate the inclusion or use of controlled substances, including without limitation, the EU RoHS Directive, and using Renesas Electronics products in compliance with all these applicable laws and regulations. Renesas Electronics disclaims any and all liability for damages or losses occurring as a result of your noncompliance with applicable laws and regulations.
 9. Renesas Electronics products and technologies shall not be used for or incorporated into any products or systems whose manufacture, use, or sale is prohibited under any applicable domestic or foreign laws or regulations. You shall comply with any applicable export control laws and regulations promulgated and administered by the governments of any countries asserting jurisdiction over the parties or transactions.
 10. It is the responsibility of the buyer or distributor of Renesas Electronics products, or any other party who distributes, disposes of, or otherwise sells or transfers the product to a third party, to notify such third party in advance of the contents and conditions set forth in this document.
 11. This document shall not be reprinted, reproduced or duplicated in any form, in whole or in part, without prior written consent of Renesas Electronics.
 12. Please contact a Renesas Electronics sales office if you have any questions regarding the information contained in this document or Renesas Electronics products.
- (Note1) "Renesas Electronics" as used in this document means Renesas Electronics Corporation and also includes its directly or indirectly controlled subsidiaries.
- (Note2) "Renesas Electronics product(s)" means any product developed or manufactured by or for Renesas Electronics.

(Rev.4.0-1 November 2017)

Corporate Headquarters

TOYOSU FORESIA, 3-2-24 Toyosu,
Koto-ku, Tokyo 135-0061, Japan
www.renesas.com

Contact Information

For further information on a product, technology, the most up-to-date version of a document, or your nearest sales office, please visit:
www.renesas.com/contact/

Trademarks

Renesas and the Renesas logo are trademarks of Renesas Electronics Corporation. All trademarks and registered trademarks are the property of their respective owners.