

## DESCRIPTION

Demonstration circuit DC676 is a complete power controller for a USB powered device. DC676 is based on the LTC4055 and provides the following functions; 700mA CC/CV timer terminated temperature qualified charger suitable for Li-Ion cells, a USB power manager that insures compliance with the USB power specification and power path management for the battery. The LTC4055 uses the intermediate bus voltage topology that results

in faster charging and lower power loss than the charger fed topology. All this functionality consumes only 100mm<sup>2</sup> of PCB area.

**Design files for this circuit board are available. Call the LTC factory.**

**Table 1. Performance Summary**

PARAMETER	CONDITION	VALUE
Input Voltage		4.3-5.5V
<b>Battery Charger</b>		
I <sub>out</sub>	V <sub>in</sub> = 5V, V <sub>bat</sub> = 3.6V	700mA +/- 7%
Float voltage	V <sub>in</sub> = 5V	4.20V +/- 1%
Trickle Charge threshold	V <sub>IN</sub> = 5V	2.9V +/- 0.1V
Recharge threshold	V <sub>in</sub> 5V	V <sub>float</sub> – 60mV – V <sub>float</sub> - 150mV
<b>USB Current</b>		
Input Current 500mA mode	V <sub>in</sub> = 5V; USB Active, 500mA mode	500mA max
Input Current 100mA mode	V <sub>in</sub> = 5V; USB Active, 100mA mode	100mA max
Input Current suspend mode	V <sub>in</sub> = 5V; USB suspend	300uA max

## OPERATING PRINCIPLES

Demo DC676 is based on the LTC4055. This chip manages the power supplies that would be typical for a USB powered device. Power is input from either the USB cable or an adapter to an intermediate voltage bus. The intermediate voltage bus is preferentially powered from

the adapter, then USB and finally if required from the battery via an ideal diode. The battery charger is a CC/CV timer terminated type capable of charge currents of up to 800mA and is roughly equivalent to the LTC4053.

## QUICK START PROCEDURE

Demonstration circuit DC676 is easy to set up to evaluate the performance of the LTC4055. Refer to Figure 1 for proper measurement equipment setup and follow the procedure below:

1. Connect input power supply, meters and output load as shown in figure 1.

### USB Charging

2. Place the MASTER ON/OFF jumper in the ON position.

- Place the USB ON/OFF jumper in the ON position. Place the USB CURRENT jumper in the 500mA position. Set the battery simulator voltage to zero, slowly raise the USB INPUT voltage. When the supply voltage exceeds 4.3V the charger should activate and the charge LED will illuminate. The battery will be in trickle charge mode. Increase the battery voltage to 3.6V. At about 2.9V the battery charge current will increase to 485mA. Note that the input current from the USB does not exceed the USB spec of 500mA.
- Now increase the load on the SYSTEM LOAD OUTPUT. Note that as the output load is increased the charging current is decreased and the USB current remains within the 500mA limit.
- Place the USB CURRENT jumper in the 100mA position and note that USB INPUT current falls to maintain compliance with the USB input current spec. Also note that as the external load is increased the battery will start to discharge into the SYSTEM LOAD OUTPUT, illustrating the ideal diode function of the LTC4055
- Place the USB ON/OFF jumper in the OFF position and note that the USB current falls to under 300uA to comply with the USB suspend mode current.

### Adapter Charging

- Ramp up the wall adapter voltage. When the wall adapter exceeds 4.3 volts the LTC4055 will cease

drawing current from the USB and switch over to the wall adapter.

- Note that the charge current to the battery has increased to 700mA.
- Increase the battery voltage to 4.2V and note that the charge current falls to 0 this illustrates the constant voltage portion of the charging characteristic.

### Battery powered Operation

- Set Both USB INPUT voltage and the ADAPTER INPUT voltage to zero. The battery will now power the load on the SYSTEM LOAD OUTPUT, illustrating the ideal diode function of the LTC4055. Note that the battery is now being discharged.

### Other

- Pins are provided to all control functions in order to simplify wiring of the demo circuit into a system board.
- NTC function; provision has been made for connection of an external 10k NTC, for temperature qualified charging. To use this feature set the NTC jumper in the external position and connect the external NTC to the NTC terminal and ground.

# QUICK START GUIDE FOR DEMONSTRATION CIRCUIT DC676 USB POWER SOLUTION IN QFN 4X4

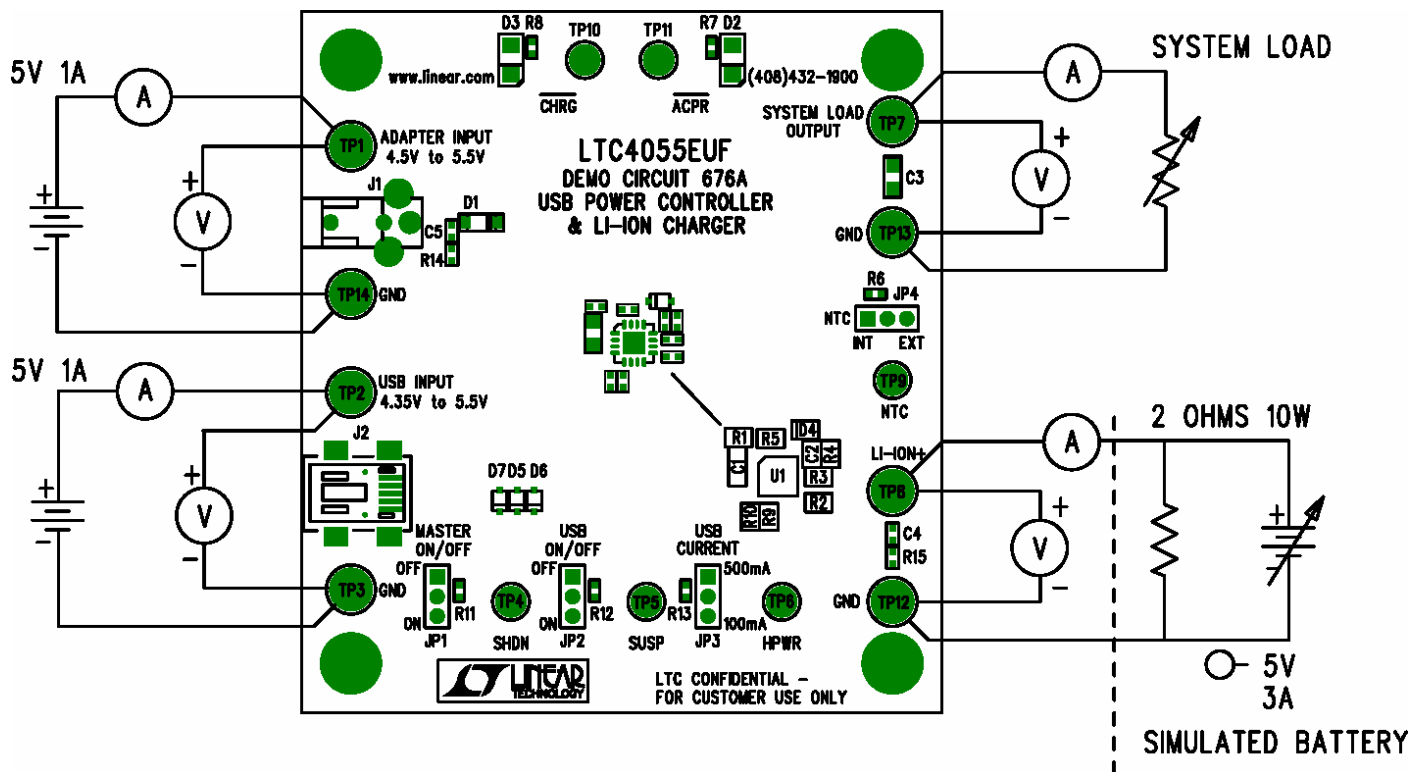
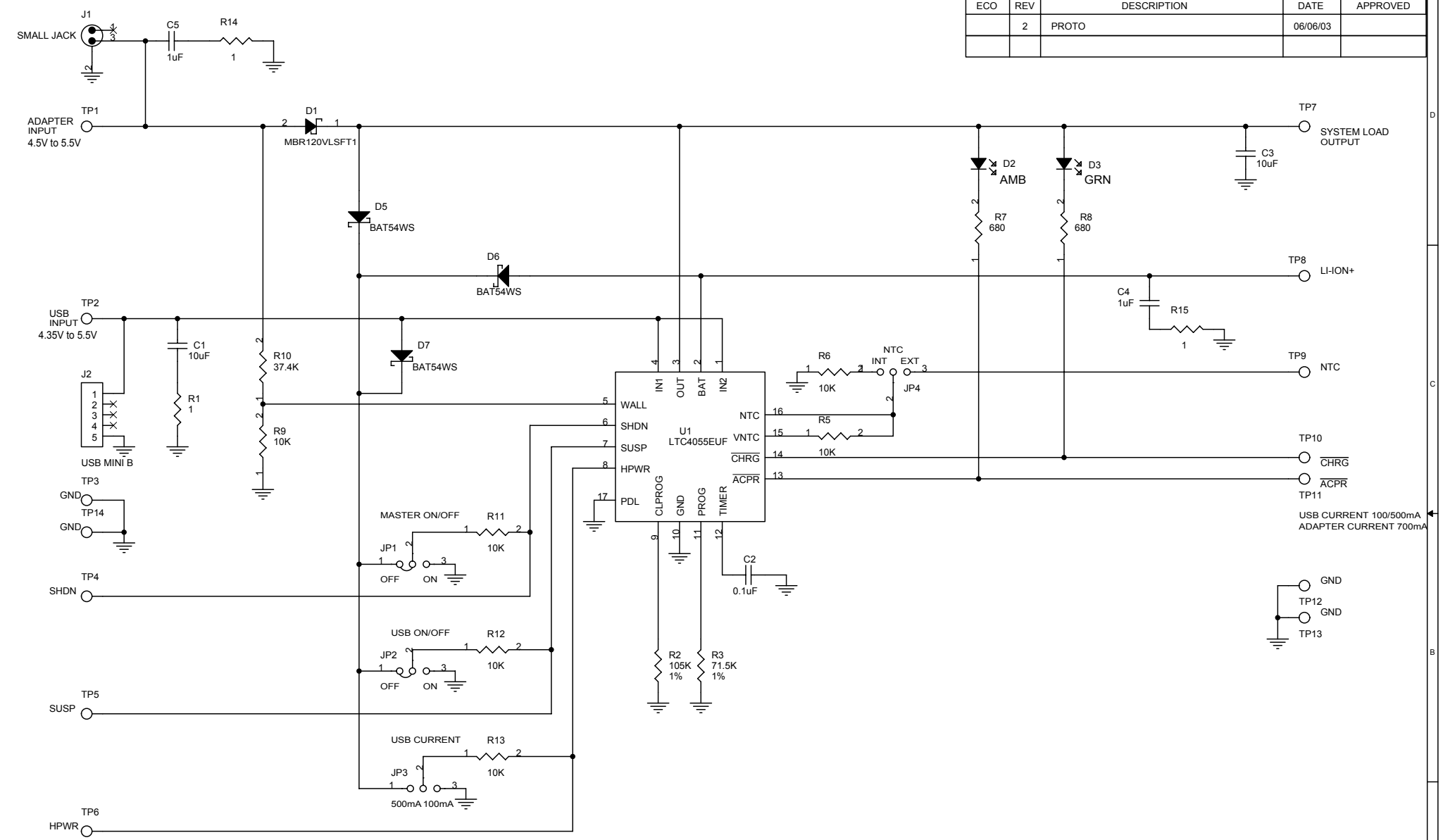

Figure 1. Proper Measurement Equipment Setup

REVISION HISTORY				
ECO	REV	DESCRIPTION	DATE	APPROVED
	2	PROTO	06/06/03	



USB CURRENT 100/500mA  
ADAPTER CURRENT 700mA

GND  
TP12  
GND  
TP13

This circuit is proprietary to Linear Technology and supplied for use with Linear Technology parts.  
**Customer Notice:** Linear Technology has made a best effort to design a circuit that meets customer-supplied specifications; however, it remains the customer's responsibility to verify proper and reliable operation in the actual application. Component substitution and printed circuit board layout may significantly affect circuit performance or reliability. Contact Linear Applications Engineering for assistance.

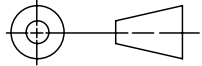
UNLESS OTHERWISE SPECIFIED DIMENSIONS ARE IN INCHES TOLERANCE ON ANGLE --- 2 PLACES --- 3 PLACES --- INTERPRET DIM AND TOL PER ASME Y14.5M -1994	CONTRACT NO.		 1630 McCarthy Blvd. Milpitas, CA 95035 Phone: (408)432-1900 Fax: (408)434-0507	
	APPROVALS	DATE		
 THIRD ANGLE PROJECTION	DRAWN MEI	04/18/03	TITLE <b>SCH, LTC4055EU, USB POWER                  CONTROLLER AND LI-ION CHARGER</b>	
	CHECKED			SIZE CAGE CODE DWG NO DC676A
	APPROVED			
	DESIGNER			
DO NOT SCALE DRAWING	Wednesday, January 07, 2004	SCALE NONE	FILENAME676A-2.DSN	SHEET 1 OF 1

<b>Item</b>	<b>Qty</b>	<b>Ref</b>	<b>Desc</b>	<b>Manufacturer / Part #</b>
1	2	C3,C1	CAP, X5R 10uF 6.3V 20% 0805	TDK C2012X5R0J106M
2	1	C2	CAP, X5R 0.1uF 10V 10% 0402	AVX 0402ZD104KAT
3	2	C4,C5	CAP, X5R 1uF 6.3V 20% 0402	TDK C1005X5R0J105M
4	1	D1	DIODE, MBR120VLSFT1	ON SEMI MBR120VLSFT1
5	1	D2	LED, AMBER	PANASONIC LN1451C-(TR)
6	1	D3	LED, GREEN	PANASONIC LN1351C-(TR)
7	4	D4,D5,D6,D7	DIODE, SCHOTTKY 200mW	DIODES INC. BAT54WS
8	4	JP1,JP2,JP3,JP4	HEADER, 3 PINS 2mm	COMM 2802S-03G2
9	4	JP1,JP2,JP3,JP4	SHUNT, 2 PINS 2mm	COMM CON. CCIJ2MM-138
10	1	J1	CONN, SMALL	CUI-STACK PJ-022-12
11	1	J2	CONN, USB MINI-A	TYCO ELECTRONICS 440247-2
12	3	R1,R14,R15	RES, 1 OHM 5% 1/16W 0402	AAC CR05-1R0JM
13	2	R3,R2	RES, 105K OHM 1% 1/16W 0402	AAC CR05-1053FM
14	1	R4	RES, 150K OHM 5% 1/16W 0402	AAC CR05-154JM
15	6	R5,R6,R9,R11,R12,R13	RES, 10K OHM 5% 1/16W 0402	AAC CR05-103JM
16	2	R7,R8	RES, 680 OHMS 5% 1/16W 0402	AAC CR05-681JM
17	1	R10	RES, 37.4K OHM 1% 1/16W 0402	AAC CR05-3742FM
18	8	TP1,TP2,TP3,TP7,TP8,TP12-TP14	TURRET	MILL-MAX 2501-2
19	6	TP4,TP5,TP6,TP9,TP10,TP11	TURRET	TPMMX\2308-2
20	1	U1	IC, LTC4055EUF QFN4X4mm	LINEAR TECH LTC4055EUF
21	4	FOR MTGS AT 4 CORNERS	SCREW, 4-40,0.25" LONG	ANY
22	4	FOR MTGS AT 4 CORNERS	STANDOFF, NYLON HEX 4-40 0.5" LONG	MICROPLASTICS 14HTSP003