

Low-Dropout Linear Regulator Controller with PGOOD Indication

General Description

The RT9024 is a low-dropout voltage regulator controller with a specific PGOOD indicating scheme. The part could drive an external N-MOSFET for various applications. The part is operated with V_{CC} power ranging from 3.8V to 13.5V. With such a topology, it's with advantages of flexible and cost-effective. The part comes to a small footprint package of SOT-23-6.

Ordering Information

- RT9024 □□
- Package Type
E : SOT-23-6
 - Lead Plating System
P : Pb Free
G : Green (Halogen Free and Pb Free)

Note :

Richtek products are :

- ▶ RoHS compliant and compatible with the current requirements of IPC/JEDEC J-STD-020.
- ▶ Suitable for use in SnPb or Pb-free soldering processes.

Marking Information

For marking information, contact our sales representative directly or through a Richtek distributor located in your area.

Typical Application Circuit

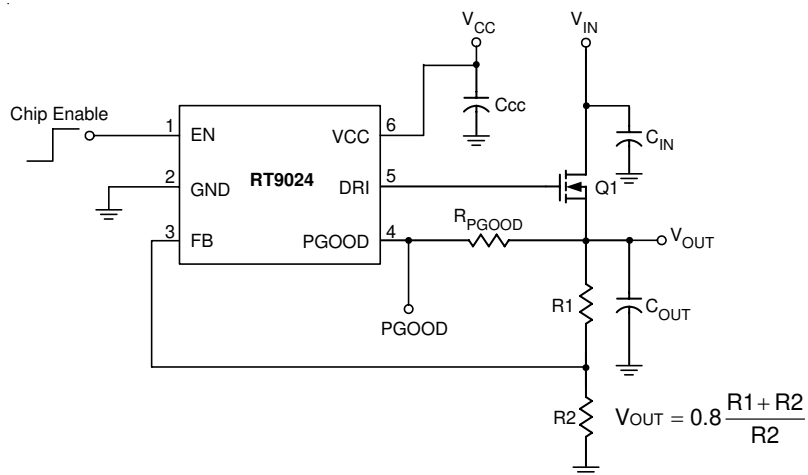

Features

- 3.8V to 13.5V Operation Voltage
- 0.8V ± 2% High Accuracy Voltage Reference
- Quick Transient Response
- Power Good Indicator with Delay
- Enable Control
- Small Footprint Package SOT-23-6
- RoHS Compliant and 100% Lead (Pb)-Free

Applications

- DSC
- DSLR

Pin Configurations

(TOP VIEW)

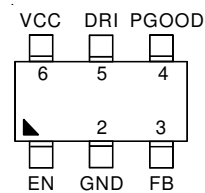

SOT-23-6

Test Circuit

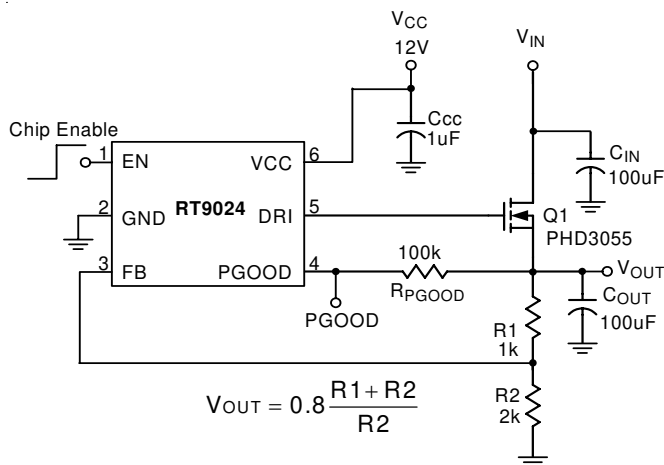

Figure 1. Typical Test Circuit

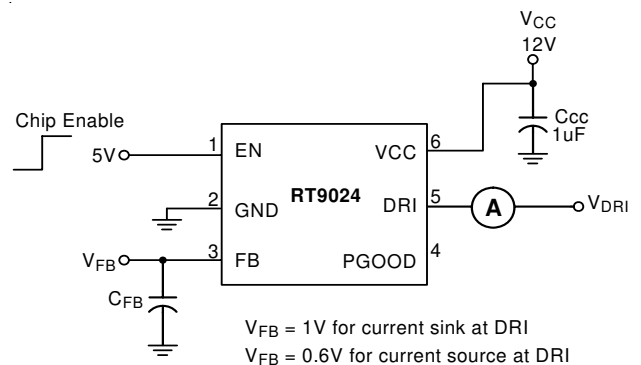
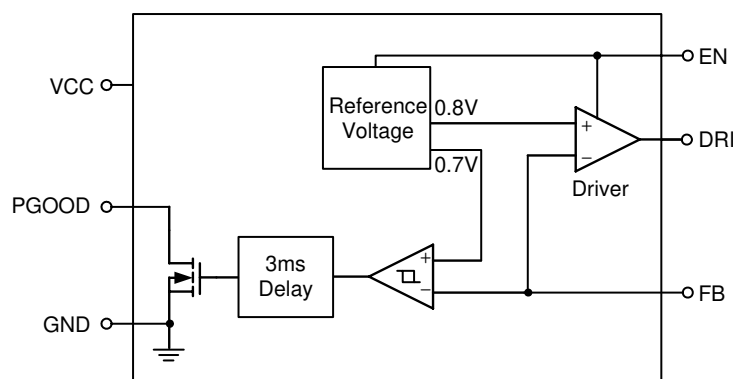

Figure 2. DRI Source/Sink Current Test Circuit

Functional Pin Description

Pin No.	Pin Name	Pin Function
1	EN	Chip Enable (Active High).
2	GND	Ground.
3	FB	Output Voltage Feedback.
4	PGOOD	Power Good Open Drain Output.
5	DRI	Driver Output.
6	VCC	Power Supply Input.

Function Block Diagram



Absolute Maximum Ratings (Note 1)

- Supply Input Voltage, V_{CC} ----- 15V
- Enable Voltage ----- 7V
- Power Good Output Voltage ----- 7V
- Power Dissipation, P_D @ $T_A = 25^\circ C$
- SOT-23-6 ----- 0.4W
- Package Thermal Resistance (Note 2)
- SOT-23-6, θ_{JA} ----- 250°C/W
- Lead Temperature (Soldering, 10 sec.) ----- 260°C
- Junction Temperature ----- 150°C
- Storage Temperature Range ----- -65°C to 150°C
- ESD Susceptibility (Note 3)
- HBM (Human Body Mode) ----- 2kV
- MM (Machine Mode) ----- 200V

Recommended Operating Conditions (Note 4)

- Supply Input Voltage, V_{CC} ----- 3.8V to 13.5V
- Enable Voltage ----- 0V to 5.5V
- Junction Temperature Range ----- -40°C to 125°C
- Ambient Temperature Range ----- -40°C to 85°C

Electrical Characteristics

($V_{CC} = 5V/12V$, $T_A = 25^\circ C$, unless otherwise specified)

Parameter	Symbol	Test Conditions	Min	Typ	Max	Unit
V_{CC} Operation Voltage Range		V_{CC} Input Range	3.8	--	13.5	V
POR Threshold		V_{CC} Rising	3.15	3.4	3.65	V
POR Hysteresis		V_{CC} Falling	0.1	0.2	0.3	V
V_{CC} Supply Current		$V_{CC} = 12V$	--	0.3	0.8	mA
Driver Source Current		$V_{CC} = 12V$, $V_{DRI} = 6V$	5	--	--	mA
Driver Sink Current		$V_{CC} = 12V$, $V_{DRI} = 6V$	5	--	--	mA
Reference Voltage (V_{FB})		$V_{CC} = 12V$, $V_{DRI} = 5V$	0.784	0.8	0.816	V
Reference Line Regulation (V_{FB})		$V_{CC} = 4.5V$ to 15V	--	3	6	mV
Amplifier Voltage Gain		$V_{CC} = 12V$, No Load	--	70	--	dB
PSRR at 100Hz, No Load		$V_{CC} = 12V$, No Load	50	--	--	dB
Power Good						
Rising Threshold		$V_{CC} = 12V$	85	90	95	%
Hysteresis		$V_{CC} = 12V$	--	15	--	%
Sink Capability		$V_{CC} = 12V$ @ 1mA	--	0.2	0.4	V
Delay Time		$V_{CC} = 12V$	1	3	10	ms
Falling Delay		$V_{CC} = 12V$	--	15	20	us

To be Continued

Parameter	Symbol	Test Conditions	Min	Typ	Max	Unit
Chip Enable						
EN Rising Threshold		$V_{CC} = 12V$	--	0.7	1	V
EN Hysteresis		$V_{CC} = 12V$	--	30	--	mV
Standby Current		$V_{CC} = 12V, V_{EN} = 0V$	--	--	5	μA

Note 1. Stresses listed as the above “Absolute Maximum Ratings” may cause permanent damage to the device. These are for stress ratings. Functional operation of the device at these or any other conditions beyond those indicated in the operational sections of the specifications is not implied. Exposure to absolute maximum rating conditions for extended periods may remain possibility to affect device reliability.

Note 2. θ_{JA} is measured in the natural convection at $T_A = 25^\circ C$ on a low effective thermal conductivity test board of JEDEC 51-3 thermal measurement standard.

Note 3. Devices are ESD sensitive. Handling precaution is recommended.

Note 4. The device is not guaranteed to function outside its operating conditions.

Typical Operating Characteristics

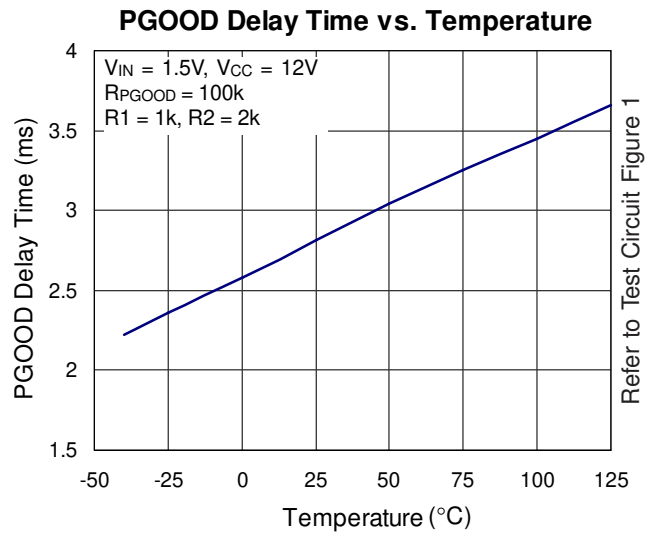
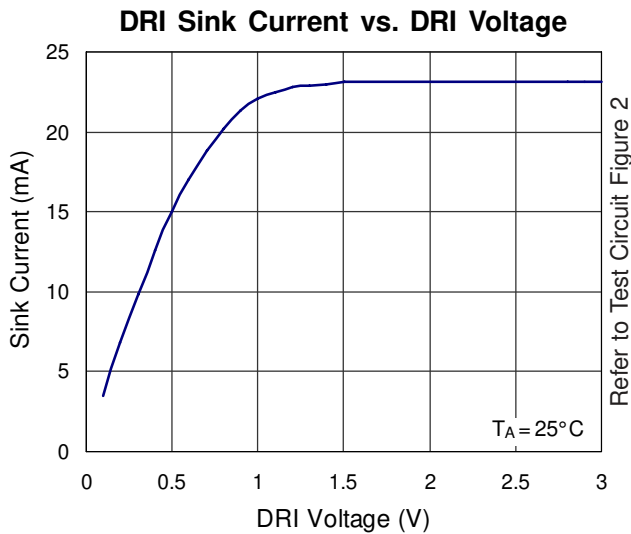
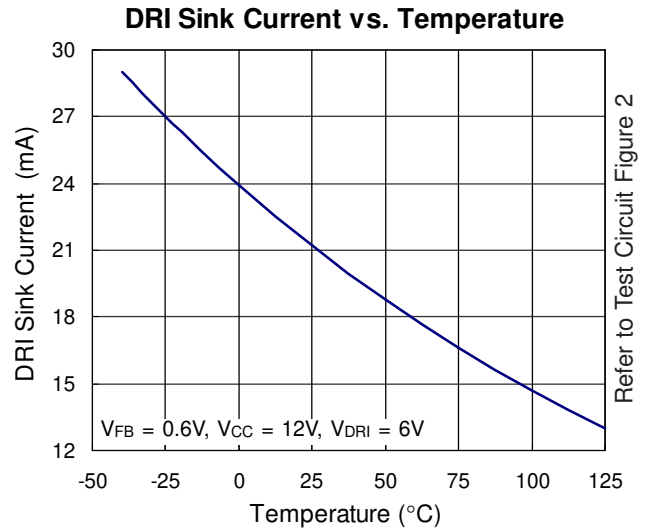
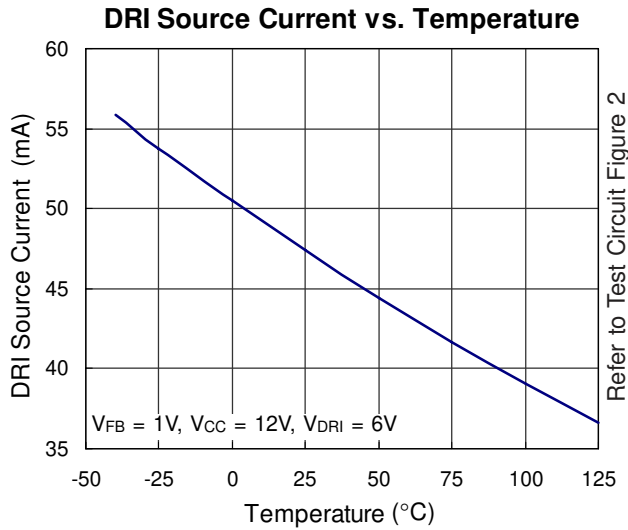
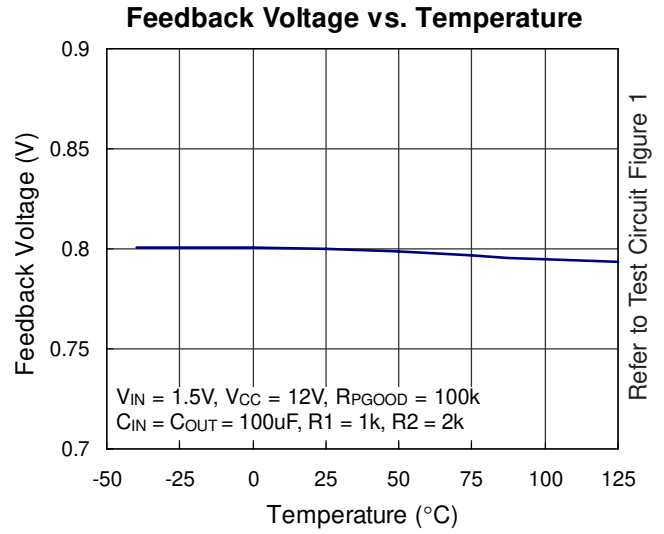
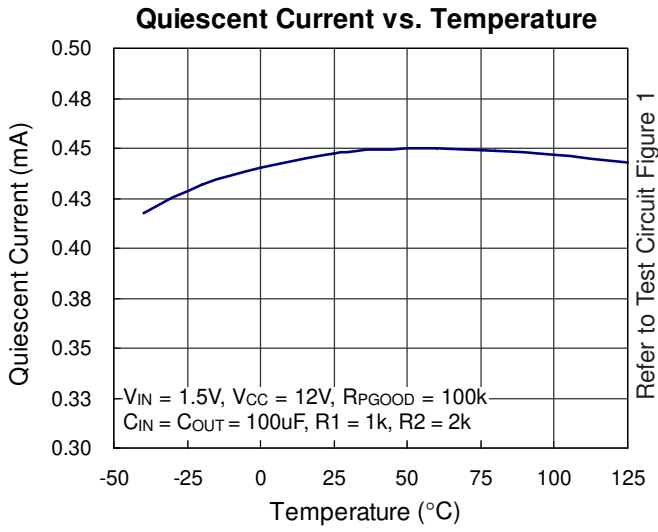

PGOOD Delay Time

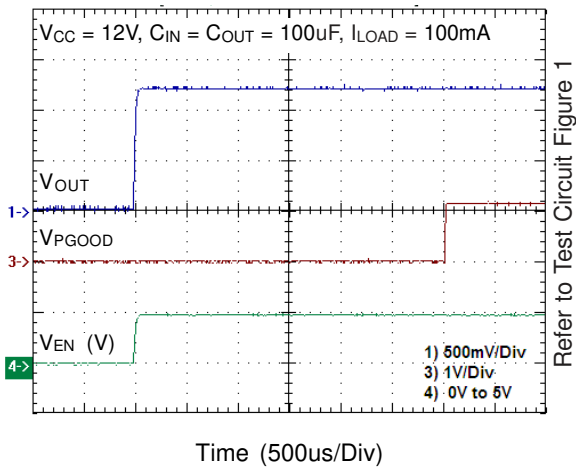

PGOOD Delay Time

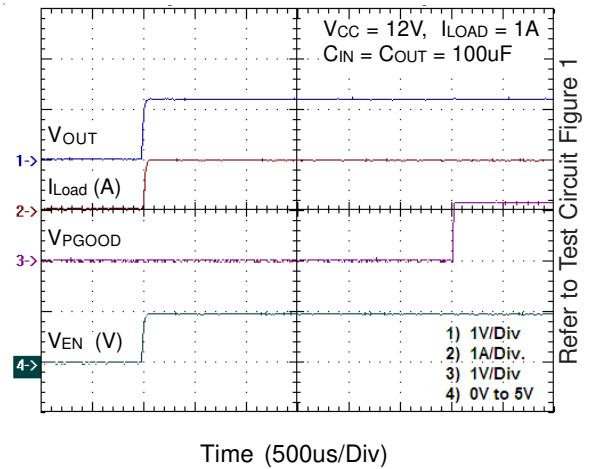

PGOOD Off

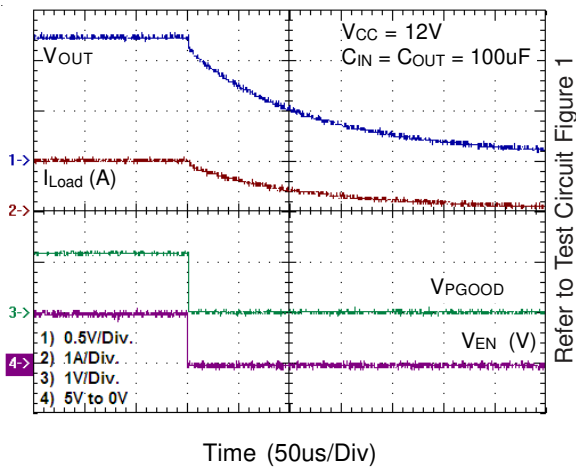

Enable Threshold Voltage vs. Temperature

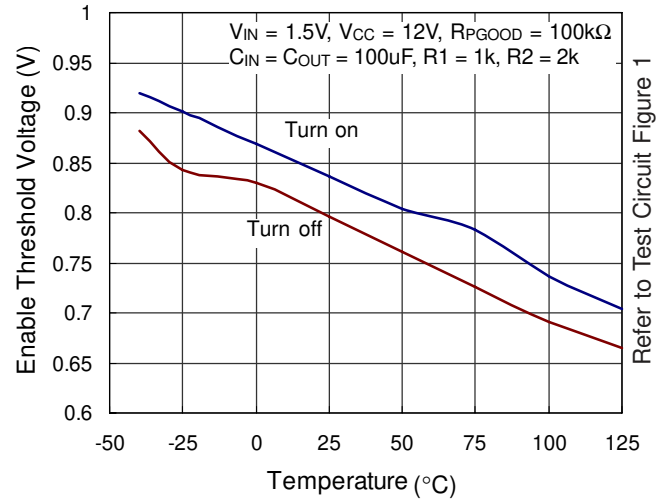

Load Transient Response

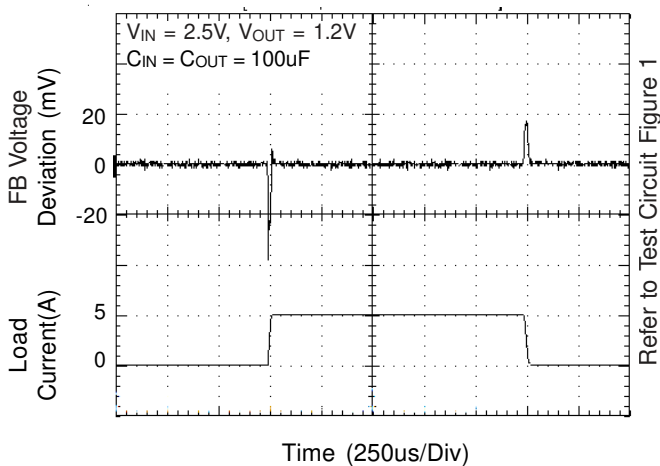

Line Transient Response

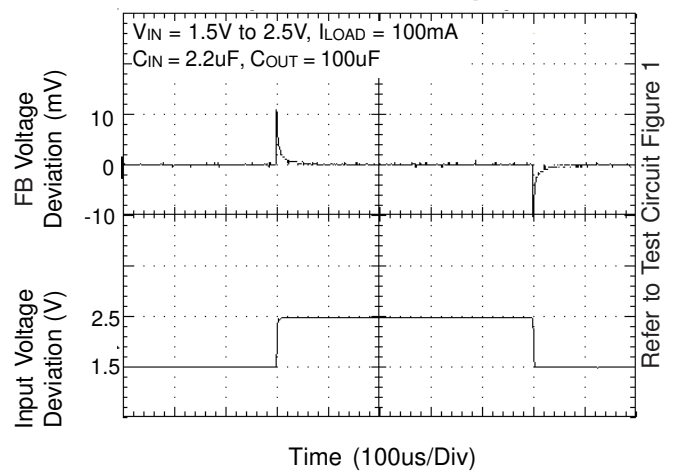

Application Information

Capacitors Selection

Careful selection of the external capacitors for RT9024 is highly recommended in order to remain high stability and performance.

Regarding the supply voltage capacitor, connecting a capacitor which is $\geq 1\mu\text{F}$ between V_{CC} and ground is a must. The capacitor improves the supply voltage stability for proper operation.

Regarding the input capacitor, connecting a capacitor which $\geq 100\mu\text{F}$ between V_{IN} and ground is recommended to increase stability. With large value of capacitance could result in better performance for both PSRR and line transient response.

When driving external pass element, connecting a capacitor $\geq 100\mu\text{F}$ between V_{OUT} and ground is recommended for stability. With larger capacitance can reduce noise and improve load transient response and PSRR.

Output Voltage Setting

The RT9024 develops a 0.8V reference voltage; especially suitable for low voltage application. As shown in application circuit, the output voltage could easy set the output voltage by R1 & R2 divider resistor.

Power Good Function

The RT9024 has the power good function with delay. The power good output is an open drain output. Connect a 100k Ω pull up resistor to V_{OUT} to obtain an output voltage. When the output voltage arrives 90% of normal value. PGOOD will become active and be pulled high by external circuits with typically 3ms delay.

Chip Enable Operation

Pull the EN pin low to drive the device into shutdown mode. During shutdown mode, the standby current drops to 5 $\mu\text{A}_{(\text{MAX})}$. The external capacitor and load current determine the output voltage decay rate. Drive the EN pin high to turn on the device again.

MOSFET Selection

The RT9024 are designed to driver external N-MOSFET pass element. MOSFET selection criteria include threshold voltage V_{GS} (V_{TH}), maximum continuous drain current I_{D} , on-resistance $R_{\text{DS(ON)}}$, maximum drain-to-source voltage V_{DS} and package thermal resistance $\theta_{(\text{JA})}$.

The most critical specification is the MOSFET $R_{\text{DS(ON)}}$. Calculate the required $R_{\text{DS(ON)}}$ from the following formula:

$$\text{N-MOSFET } R_{\text{DS(ON)}} = \frac{V_{\text{IN}} - V_{\text{OUT}}}{I_{\text{LOAD}}}$$

For example, the MOSFET operate up to 2A when the input voltage is 1.5V and set the output voltage is 1.2V, $R_{\text{ON}} = (1.5\text{V} - 1.2\text{V}) / 2\text{A} = 150\text{m}\Omega$, the MOSFET's R_{ON} must be lower than 150m Ω . Philip PHD3055E MOSFET with an $R_{\text{DS(ON)}}$ of 120m Ω (typ.) is a suitable solution.

The power dissipation is calculate as :

$$P_{\text{D}} = (V_{\text{IN}} - V_{\text{OUT}}) \times I_{\text{LOAD}}$$

The thermal resistance from junction to ambient $\theta_{(\text{JA})}$ is :

$$\theta_{(\text{JA})} = \frac{(T_{\text{J}} - T_{\text{A}})}{P_{\text{D}}}$$

In this example, $P_{\text{D}} = (1.5\text{V} - 1.2\text{V}) \times 2\text{A} = 0.6\text{W}$. The PHD3055E's $\theta_{(\text{JA})}$ is 75 $^{\circ}\text{C}/\text{W}$ for its D-PAK package, which translates to a 45 $^{\circ}\text{C}$ temperature rise above ambient. The package provides exposed backsides that directly transfer heat to the PCB board.

PNP Transistor Selection

The RT9024 could driver the PNP transistor to sink output current. PNP transistor selection criteria include DC current gain h_{FE} , threshold voltage V_{EB} , collector-emitter voltage V_{EN} , maximum continues collector current I_{C} , package thermal resistance $\theta_{(\text{JA})}$.

For example, the PNP transistor operates sink current up to 0.5A when the input voltage is 1.5V and set the output voltage is 1.2V. As show in Figure 3. A KSB772 PNP transistor, the $V_{\text{EN}} = 1.2\text{V}$, $V_{\text{BE}} = -1\text{V}$, $I_{\text{C}} = 0.5\text{A}$, $I_{\text{B}} = 0.5 / 160 \geq 3.125\text{mA}$, when the DRI pin voltage is 0.2V could sink 6.8mA $_{(\text{MAX})}$ is a close match.

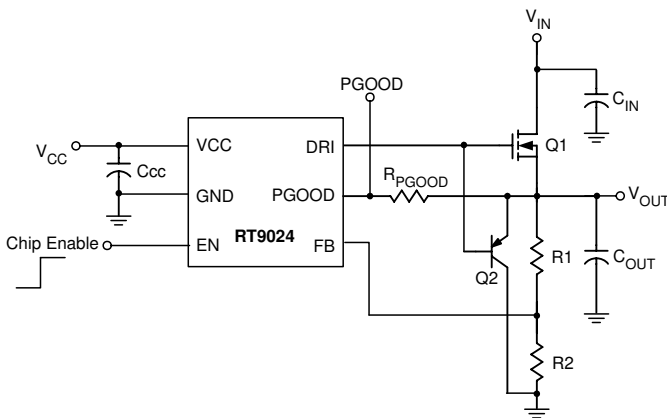

Figure 3

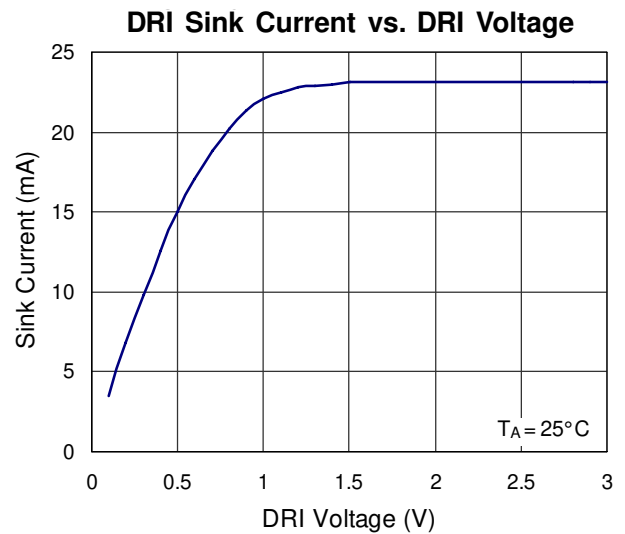

Figure 4

Layout Considerations

There are three critical layout considerations. One is the divider resistors should be located to RT9024 as possible to avoid inducing any noise. The second is capacitors place. The C_{IN} and C_{OUT} have to put at near the N-MOSFET for improve performance. The third is the copper area for pass element. We have to consider when the pass element operating under high power situation that could rise the junction temperature. In addition to the package thermal resistance limit, we could add the copper area to improve the power dissipation. As show in Figure 5 and Figure 6.

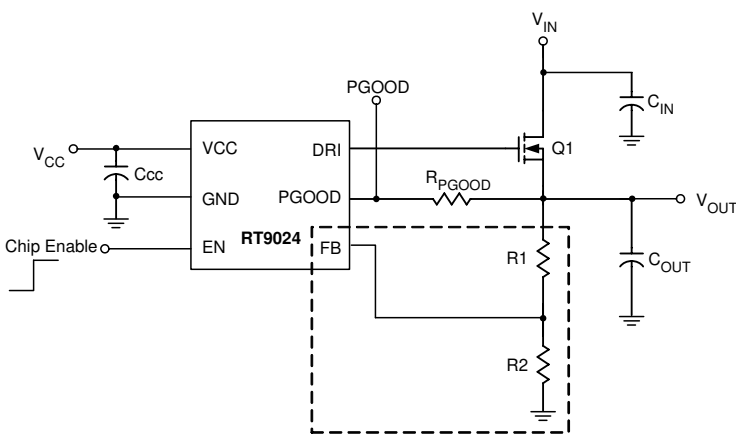

Figure 5

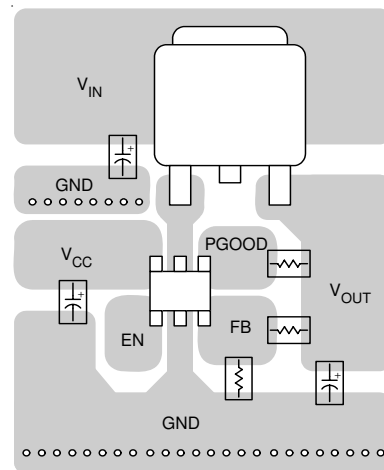
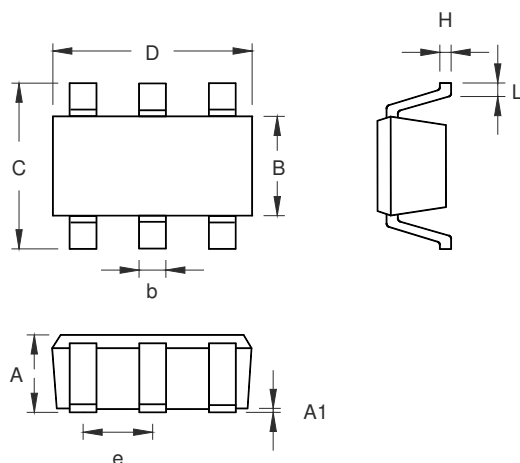

Figure 6

Outline Dimension



Symbol	Dimensions In Millimeters		Dimensions In Inches	
	Min	Max	Min	Max
A	0.889	1.295	0.031	0.051
A1	0.000	0.152	0.000	0.006
B	1.397	1.803	0.055	0.071
b	0.250	0.560	0.010	0.022
C	2.591	2.997	0.102	0.118
D	2.692	3.099	0.106	0.122
e	0.838	1.041	0.033	0.041
H	0.080	0.254	0.003	0.010
L	0.300	0.610	0.012	0.024

SOT-23-6 Surface Mount Package

Richtek Technology Corporation

Headquarter
 5F, No. 20, Taiyuen Street, Chupei City
 Hsinchu, Taiwan, R.O.C.
 Tel: (8863)5526789 Fax: (8863)5526611

Richtek Technology Corporation

Taipei Office (Marketing)
 5F, No. 95, Minchiuan Road, Hsintien City
 Taipei County, Taiwan, R.O.C.
 Tel: (8862)86672399 Fax: (8862)86672377
 Email: marketing@richtek.com

Information that is provided by Richtek Technology Corporation is believed to be accurate and reliable. Richtek reserves the right to make any change in circuit design, specification or other related things if necessary without notice at any time. No third party intellectual property infringement of the applications should be guaranteed by users when integrating Richtek products into any application. No legal responsibility for any said applications is assumed by Richtek.