

TECHNICAL CHARACTERISTICS

MATERIAL  
 INSULATOR: PA 66  
 FLAMMABILITY RATING: UL94-V0  
 COLOR: WHITE  
 PITCH: 1.00 MM

ENVIRONMENTAL  
 OPERATING TEMPERATURE: -25 UP TO 85°C  
 COMPLIANCE: LEAD FREE AND ROHS

ELECTRICAL  
 INSULATOR RESISTANCE: >100 MΩ  
 DIELECTRIC WITHSTANDING VOLTAGE: 500 VAC/MN

STANDARD  
 CERTIFIED: E323964

PACKAGING  
 BAG

DIMENSION  
 A = NB. POLE - 1  
 B = NB. POLE + 3

RoHS Compliant

PROJECTION:



GENERAL TOLERANCE

.X =  $\pm 0.2$   
 .XX =  $\pm 0.15$



APPROVAL: BBu

UNIT: MM

SCALE:

SHEET: 1/3

DRAW: AS

DESCRIPTION: WR-WTB 1.00 MM FEMALE TERMINAL HOUSING

WERI PART NO: 665 0xx 113 322

SIZE

**A4**

B	14-OCT-14	TPK DWG UPDATE	QL					
A	24-JUL-14	PDF	AS					
REV	DATE	FILE	BY					

1

2

3

4

5

Note:

1.Dimension:

Carton Size:40\*28\*28(cm)

A

B

C

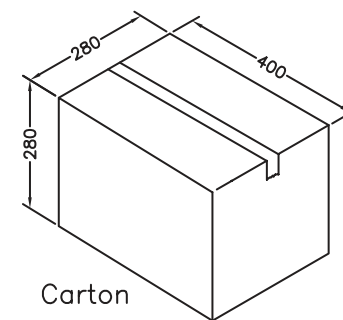
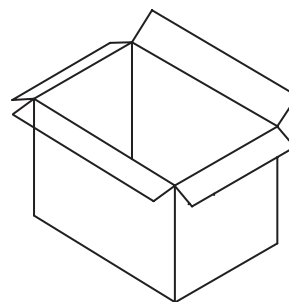
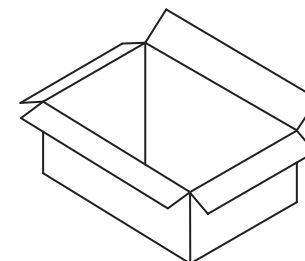
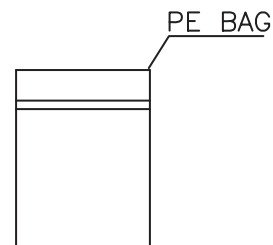

D

Pin.	Pcs/Bag	Pcs/Carton	Pin.	Pcs/Bag	Pcs/Carton
2	1000	60000	9	1000	28000
3	1000	54000	10	1000	26000
4	1000	48000	11	1000	26000
5	1000	42000	12	1000	22000
6	1000	36000	13	1000	20000
7	1000	30000	14	1000	18000
8	1000	28000	15	1000	18000

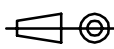

Carton

RoHS Compliant

G				PROJECTION: 	GENERAL TOLERANCE .X = +/- 0.2 .XX = +/- 0.15		
F							
E							
D							
C				APPROVAL: BBu	UNIT: MM	DESCRIPTION: WR-WTB 1.00 MM FEMALE TERMINAL HOUSING	
B					SCALE:		
A	23-AVR-15	NBR PIECES/BAG	QP		SHEET: 2/3		WERI PART NO: 665 0xx 113 322
REV	DATE	FILE	BY		DRAW: AS		

SIZE

A4

1

2

3

4

5

## Cautions and Warnings:

This electronic component is designed and developed with the intention for use in general electronics equipments.

Before incorporating the components into any equipments in the field such as aerospace, aviation, nuclear control, submarine, transportation, (automotive control, train control, ship control), transportation signal, disaster prevention, medical, public information network etc. where higher safety and reliability are especially required or if there is possibility of direct damage or injury to human body, Würth Elektronik must be asked for a written approval.



In addition, even electronic component in general electronic equipments, when used in electrical circuits that require high safety, reliability functions or performance, the sufficient reliability evaluation-check for the safety must be performed before by the user before usage.

A

B

C

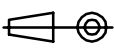
RoHS Compliant

G				PROJECTION: 	GENERAL TOLERANCE .X = +/- 0.2 .XX = +/- 0.15		
F							
E							
D							
C				APPROVAL: JC	UNIT: MM	DESCRIPTION: DISCLAIMER	SIZE <b>A4</b>
B					SCALE:		
A	10-SEP-14	PDF	QL		SHEET: 3/3	WERI PART NO: DISCLAIMER	
REV	DATE	FILE	BY		DRAW: QL		

D