

MINIMUM BOARD THICKNESS IS 1.75MM

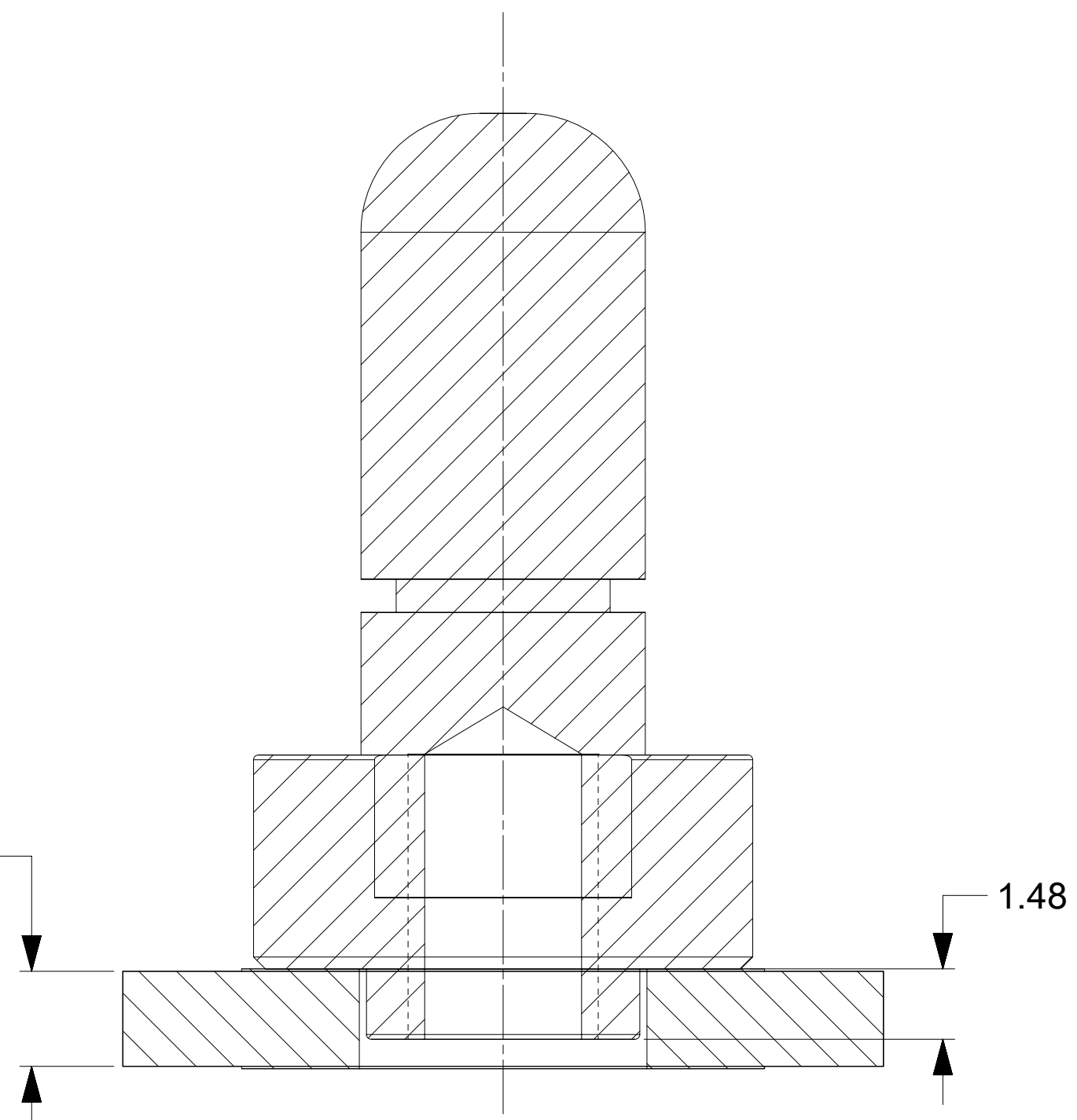

SECTION A-A

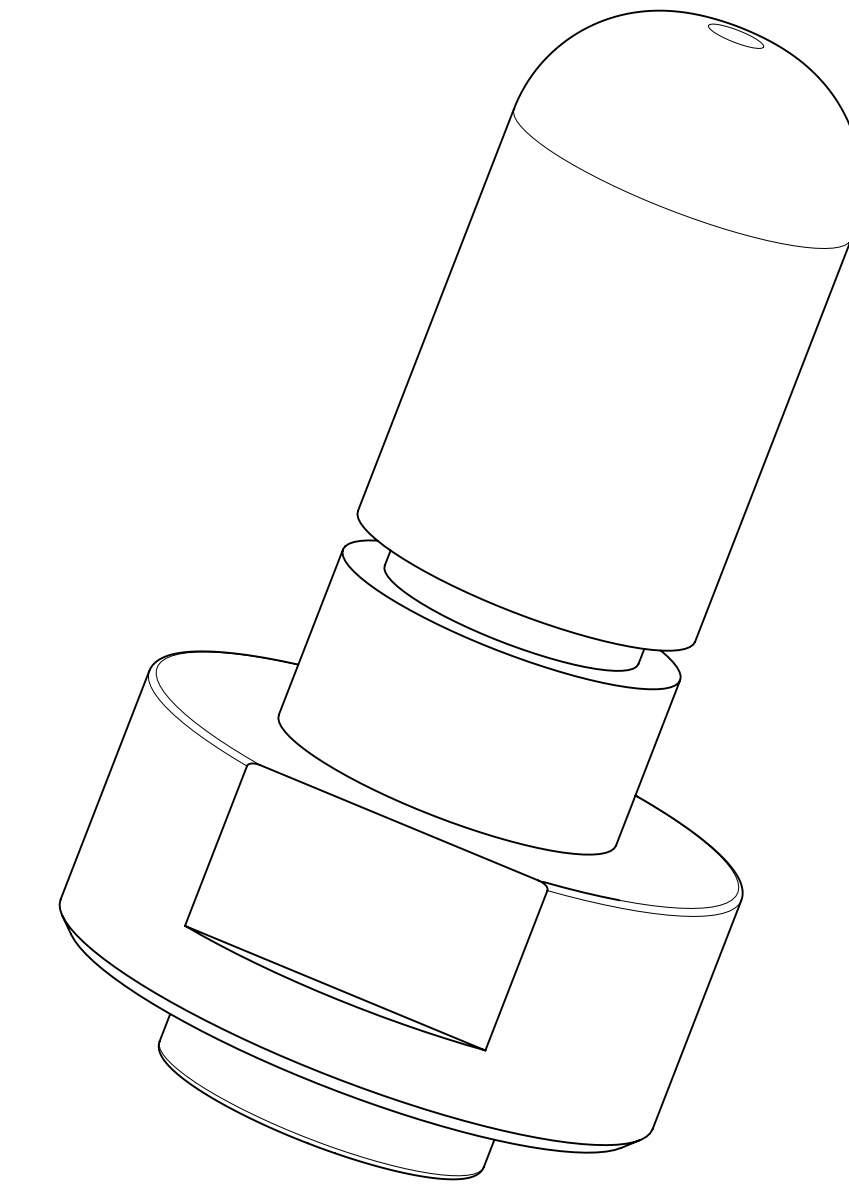
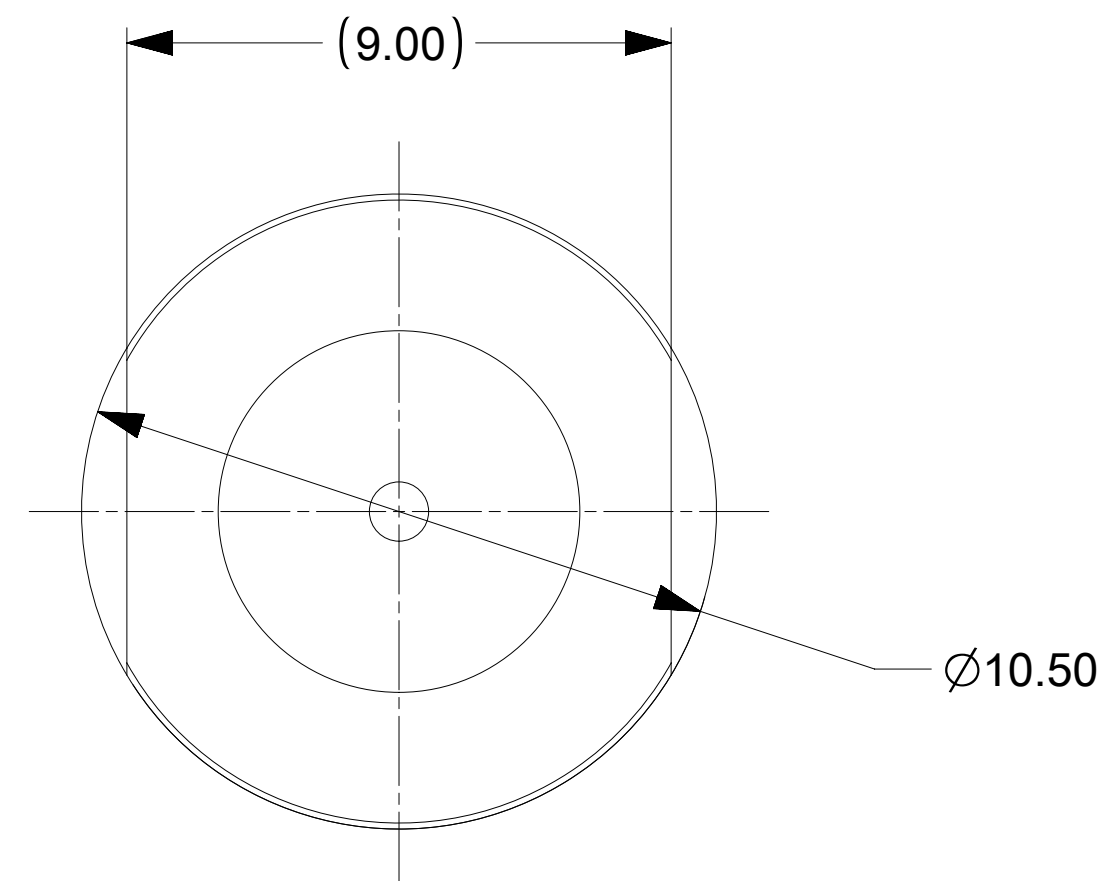

NOTES:

- MATERIALS:
BASE METAL: HIGH CONDUCTIVE COPPER ALLOY
PLATING ON BODY: 3.18 MICRON MIN SILVER OVER 1.27 MICRON MIN NICKEL
- SILVER COMPONENTS WILL BE SUPPLIED TARNISH FREE BUT MAY TARNISH OVER TIME.
- PART TO BE MOUNTED WITH CONDUCTIVE M4 SCREW AND CONDUCTIVE BELLEVILLE WASHER FOR OPTIMAL PERFORMANCE
- SCREW LENGTH TO BE DETERMINED BY CUSTOMER BASED ON THE PCB/BUS BAR THICKNESS, SCREWS AND WASHERS ARE NOT SUPPLIED BY MOLEX.
- PRODUCT SPECIFICATION: 2178840001-PS
- APPLICATION SPECIFICATION: 2178840001-AS
- PACKAGING SPECIFICATION: BULK PACKAGING AS PER 2183350001-PK

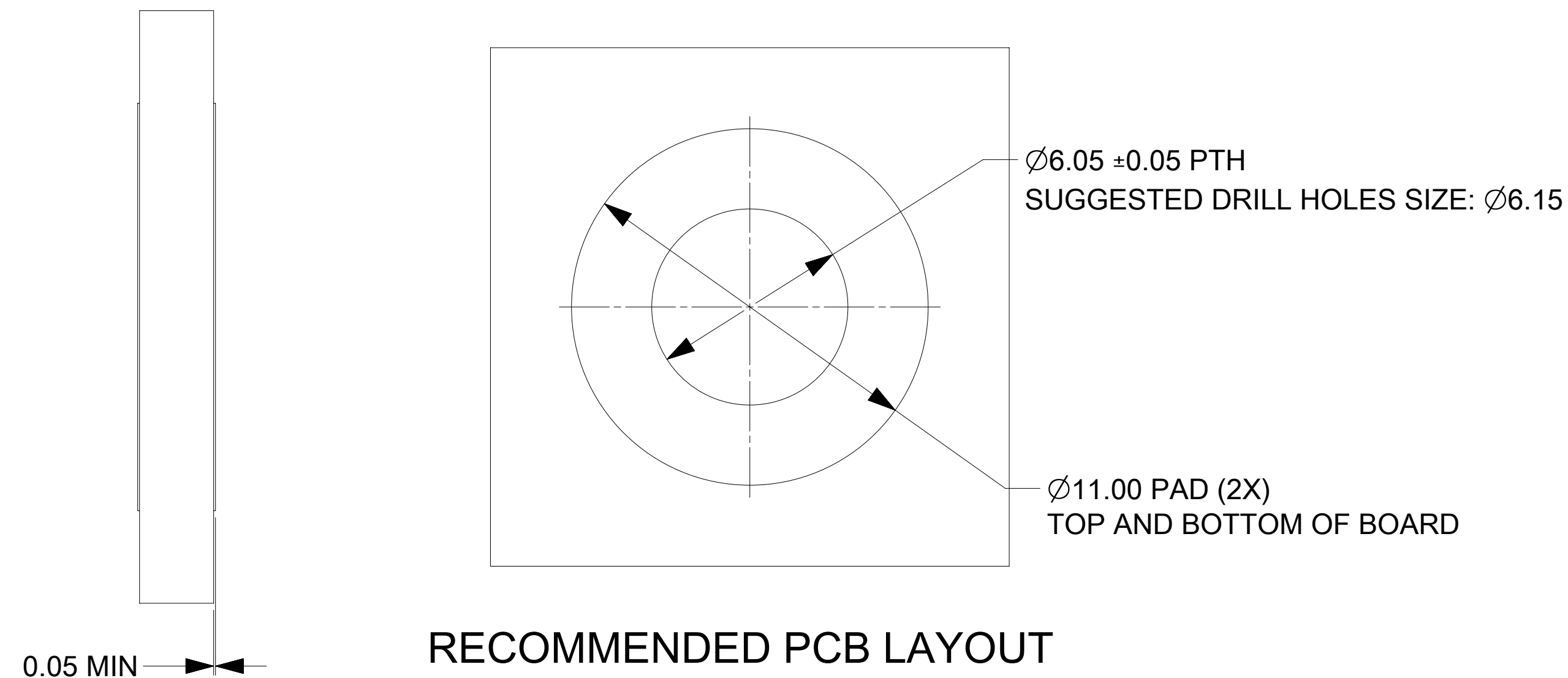

RECOMMENDED PCB LAYOUT



RECOMMENDED BUS BAR

THIS DRAWING CONTAINS INFORMATION THAT IS PROPRIETARY TO MOLEX ELECTRONIC TECHNOLOGIES, LLC AND SHOULD NOT BE USED WITHOUT WRITTEN PERMISSION											
DIMENSION UNITS	SCALE	CURRENT REV DESC: PRODUCT RELEASE									
mm	2:1	<p style="text-align: center;">6MM SW1 SCREW MOUNT LOCKING PIN</p> <p style="text-align: center;">PRODUCT CUSTOMER DRAWING</p>									
GENERAL TOLERANCES (UNLESS SPECIFIED)											
ANGULAR TOL	± 0.5°										
4 PLACES	±										
3 PLACES	±										
2 PLACES	± 0.15										
1 PLACE	± 0.25	EC NO: 741091	DRWN: SREENA1		2022/11/24		DOC TYPE		DOC PART	REVISION	
0 PLACES	±	INITIAL REVISION:	DRWN: SMAHAJANSHET		2021/04/02		2021/05/20		PSD	000	A2
DRAFT WHERE APPLICABLE MUST REMAIN WITHIN DIMENSIONS		THIRD ANGLE PROJECTION	DRAWING	SERIES	MATERIAL NUMBER	CUSTOMER	SHEET NUMBER				
			D-SIZE	218371	2183710001	GENERAL MARKET	1 OF 1				